

# #2065

## DUAL FRAME

### TENSIONING INSTRUCTIONS

## 1 FLEXIBLE SIGN FABRIC REQUIREMENTS

Recommended Sign Face Weight 14-22 oz.

**TOOLS REQUIRED:** SignComp Tension Tool, Part #5135    Razor Blade or Utility Knife  
 Pen or Marker    Standard Slotted Screw Driver

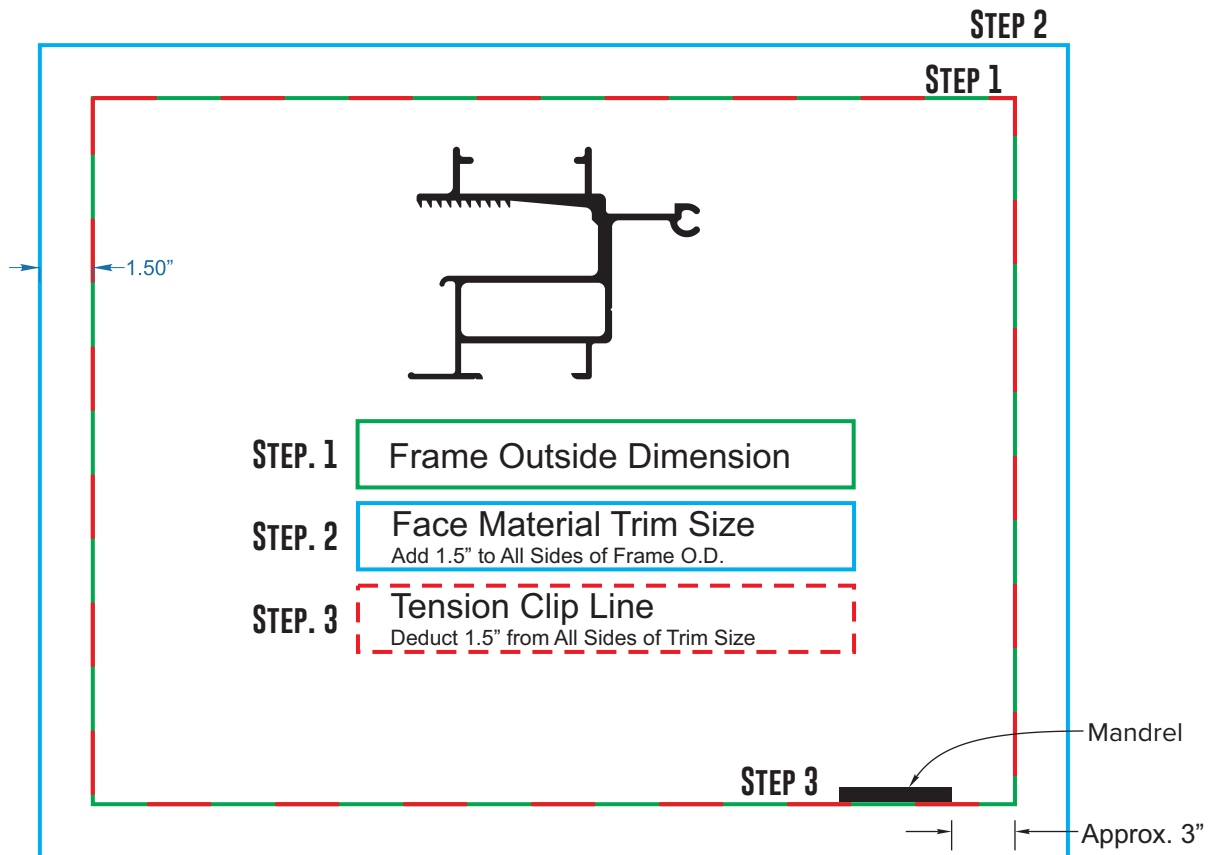

## 2 TENSION CLIP PLACEMENT

Place Tension Clips approximately 6" On Center

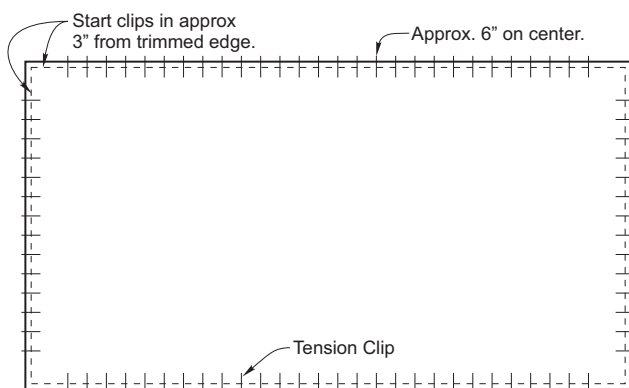

Tension Clips must be placed on the clip line approx. 3" in from trimmed edge at each corner to ensure the clip engages properly.

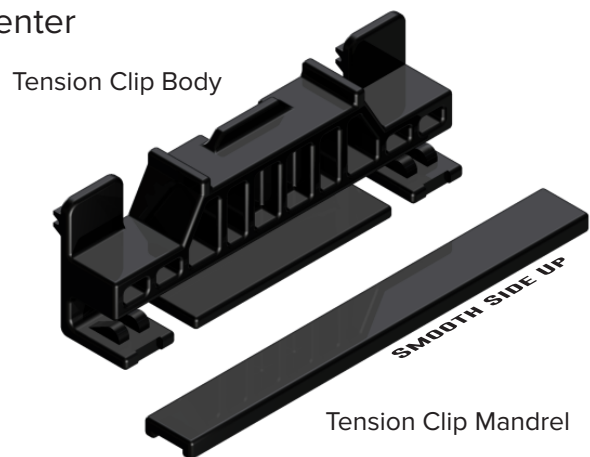

The Tension Clip is comprised of two components: The Tension Clip Body and the Tension Clip Mandrel.

# #2065

## DUAL FRAME

### TENSIONING INSTRUCTIONS

## 3 TENSION CLIP ATTACHMENT

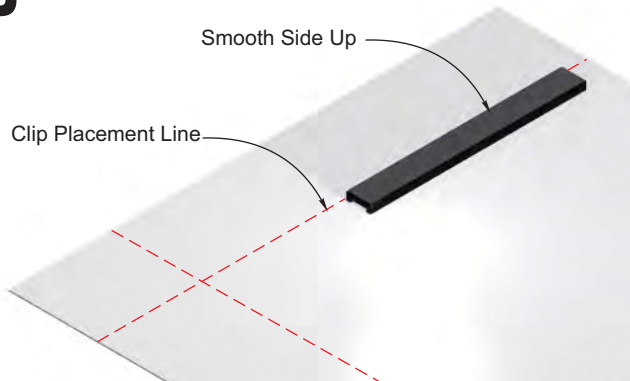

1.) Place the Mandrel, SMOOTH SIDE UP, on the fabric just inside the Clip Placement Line.

**IMPORTANT** - Tension Clips are attached to the fabric GRAPHIC SIDE UP.



2.) Fold the fabric over the Mandrel.

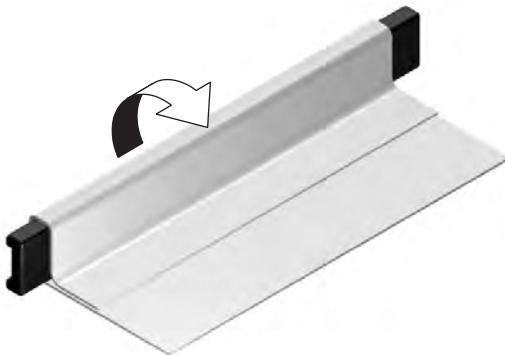

3.) Rotate the fabric and Mandrel forward by lifting the edge nearest you to stand the Mandrel and fabric up on its edge.

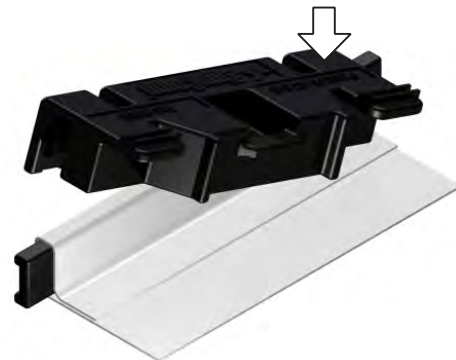

4.) With the SignComp Logo up, use firm thumb or palm pressure to drive one end of the clip body down on to the Mandrel and fabric.

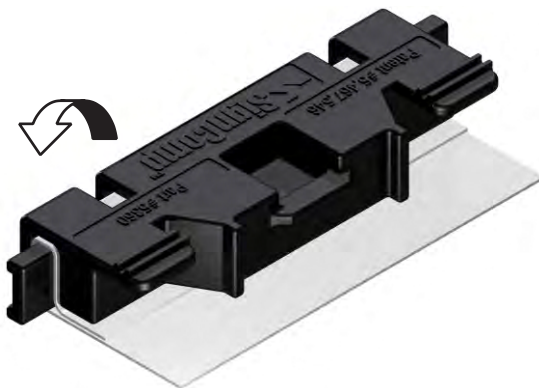

5.) Using firm thumb or palm pressure drive the remaining end down on to the Mandrel and fabric.

**\*Do not drive both ends of the clip body down on to the Mandrel and fabric at the same time.**

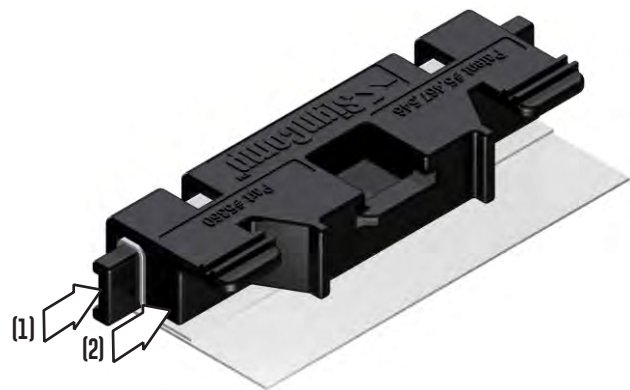

6.) The Tension Clip position may be adjusted without removing the Tension Clip from the fabric. Slide the Mandrel (1) in the direction you wish to move the clip. Followed by sliding the Clip Body (2). Repeat this procedure until position adjustment is achieved.

**The Tension Clip may be removed from the fabric by pulling the Tension Clip Body straight up and away from the fabric and Mandrel.**

# #2065 DUAL FRAME

## TENSIONING INSTRUCTIONS

### 4 TENSIONING & CLIP REMOVAL

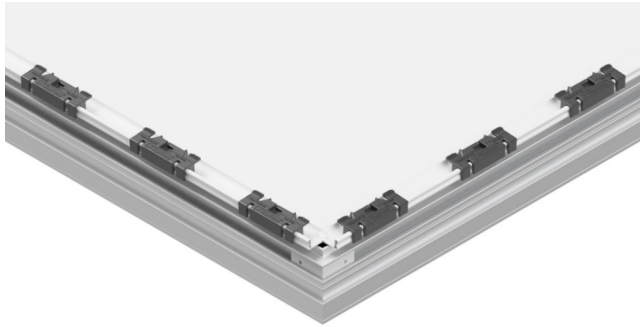

1.) With the tension channel face up, lay the fabric, with the Tension Clips attached, over the assembled frame graphic side up.

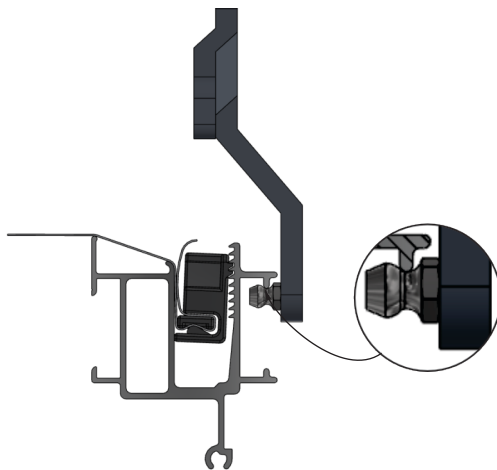

3.) Hook the Tension Tool tip under the outside rail of the assembled frame.

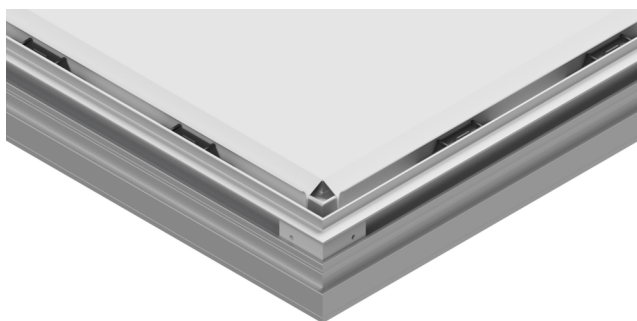

5.) It may be necessary to go around a second time to reach a smooth flat look. If needed add a click or two in the area that requires additional tension. **DO NOT OVER TENSION THE FACE.**

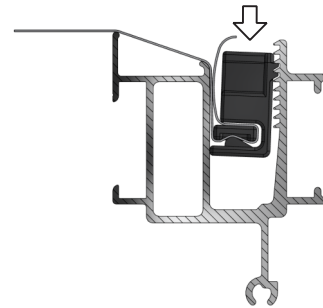

2.) Insert the clip in one or two clicks into the Tension Channel. Work your way around the frame perimeter until all the clips have been inserted. **Before applying tension**, remove any major wrinkles with necessary adjustments in the face material.

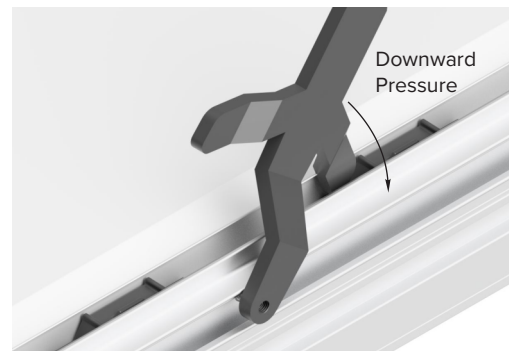

4.) Using gentle, consistent pressure, force the Tension Clip downward into the Tension Channel a couple clicks on any portion of the clip. Slide the Tension Tool along the rail and repeat the process until all of the clips have been tensioned.

#### TENSION CLIP REMOVAL

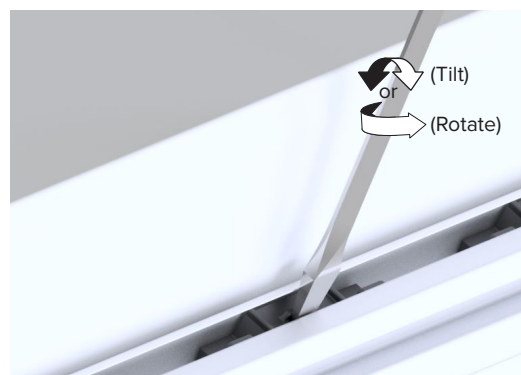

1.) Insert the Screw Driver into the Tension Clip recess.  
2.) Rotate or Tilt the Screwdriver to release the Tension Clip Teeth away from the frame.  
3.) Remove Tension Clip from Tension Channel. Pressing on face will assist in the clip coming up and out of the channel.