



NEW ARCHITECTURAL PRODUCT UPDATES: Hinge Bodies & Retainer

	Part Number	Part	Length	Finish
	1604	Series 6 Hinge Body	24'-5"	Mill
	1601	Series 4 Single Face Hinge Body	24'-5"	Mill
	1627	1/2" Slide Retainer	24'-5"	Mill

Features & Benefits

- Ideal for LED applications
- Series 4 and Series 6 bodies can be used with all SignComp Architectural retainers and/or access frames w/ covers
- Hingeable for service with minimal to no reveal between the body and retainers
- 1/2" Slide Retainer is best used for interior applications

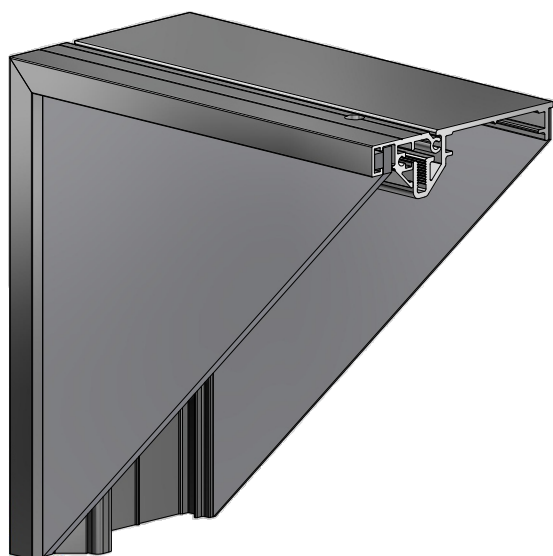
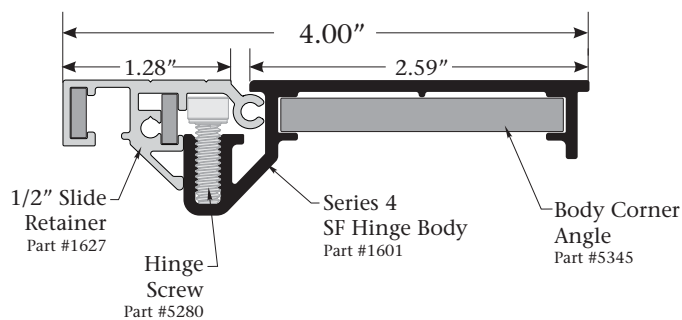
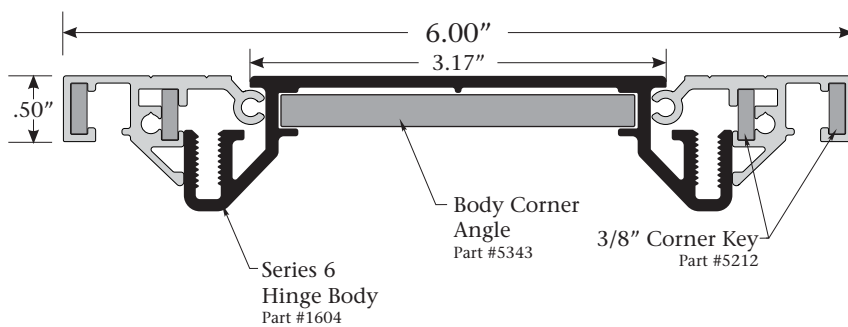

Series 4 SF Hinge Body
w/ 1/2" Slide Retainer

Retainer Options:



Slide Retainer
Part #1624



3/4" Slide Retainer
Part #1626



Frameless Retainer
Part #1631



Bleed Retainer
Part #1632



Insert Retainer
Part #1666

Note: The 1-1/4" Divider, Part #1662 does not integrate with the 1/2" Retainer, Part #1627