

Parts List			
ITEM	PART #	DESCRIPTION	NOTES
1	1923	1Part 9" Double Face Body	Top, Bottom and One End
2	1928	2Part 9" Double Face Body	One End
3	5210	Corner Key	
4	1944	2Part Retainer	
24	5290	2Part Retainer Screw	Drill 1/8" Pilot Hole, 10" - 12" on Center

D

C

B

A

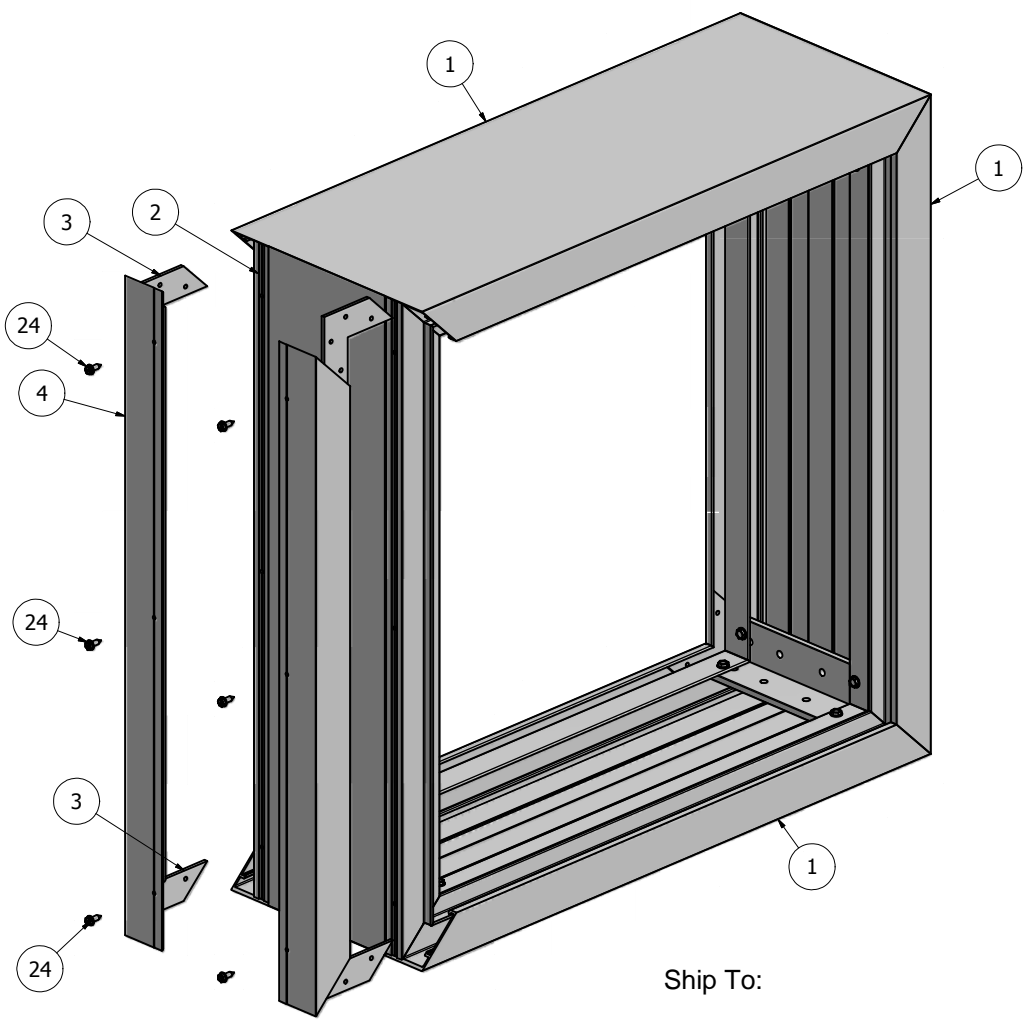

Ship To:

Order Number:

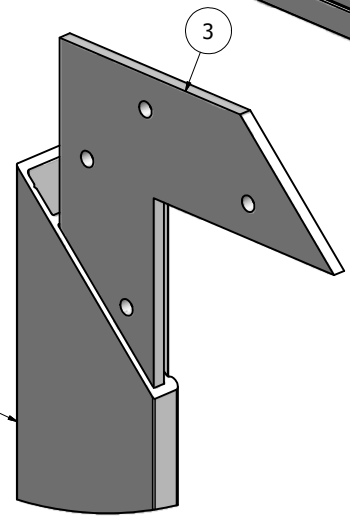
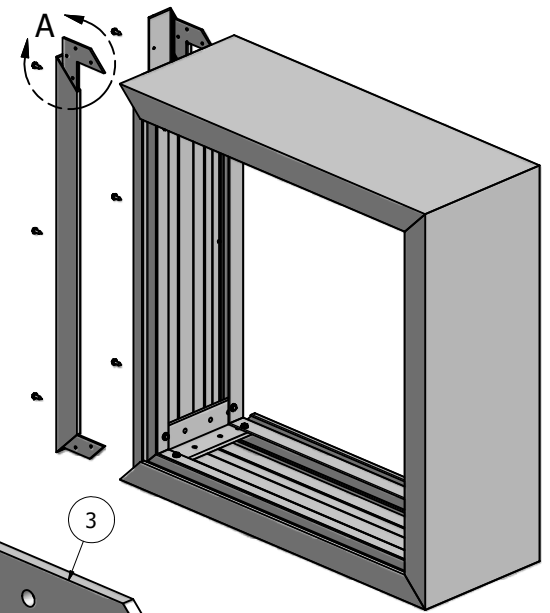

DETAIL A

**NOTE: PRE-CUT KITS ARE NOT PRE-DRILLED.**  
 (Holes shown in this drawing are for reference only.  
 Drilling of pilot holes are to be done by fabricator.)

THIS DRAWING WAS CREATED AT NO CHARGE TO ASSIST YOU IN VISUALIZING OUR PROPOSAL. THE DRAWING HEREIN IS THE PROPERTY OF SIGNCOMP. PERMISSION TO COPY OR REVISE THIS DRAWING OR TO USE THIS DRAWING FOR PRODUCTION IS STRICTLY PROHIBITED AND CAN ONLY BE COPIED, REVISED OR USED FOR PRODUCTION WITH THE EXPRESSED WRITTEN PERMISSION OF SIGNCOMP.

DRAWN	Steve	6/16/2010	<b>SignComp</b>		
CHECKED					
QA			TITLE		
MFG			1Part 2Part 9" Double Face Body - 2Part Retainer - Assembly		
APPROVED			SIZE	DWG NO	REV
			C	1923-28-44	
			SCALE	SHEET 1 OF 1	

D

C

B

A

Parts List			
ITEM	PART #	DESCRIPTION	NOTES
1	1923	1Part 9" Double Face Body	Top, Bottom & One End
2	1928	2Part 9" Double Face Body	One End
3	5978	1Part 2Part 9" Double Face Body Corner Angle	
27	5218	Corner Angle Screw	Drill 5/32" pilot Hole
4	5210	Corner Key	

Ship To:

Order Number:

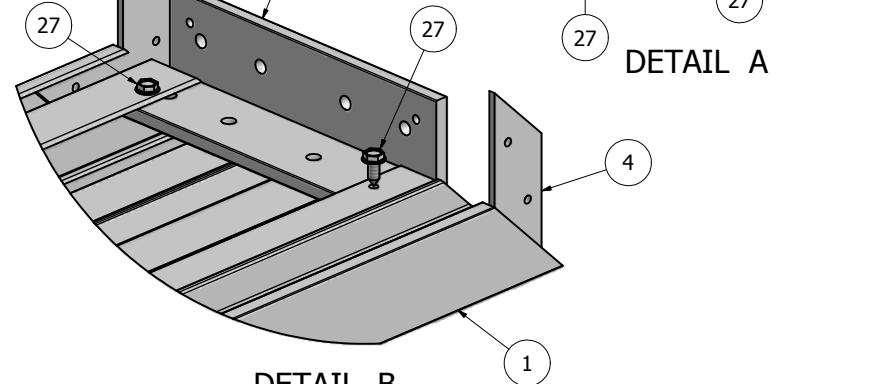
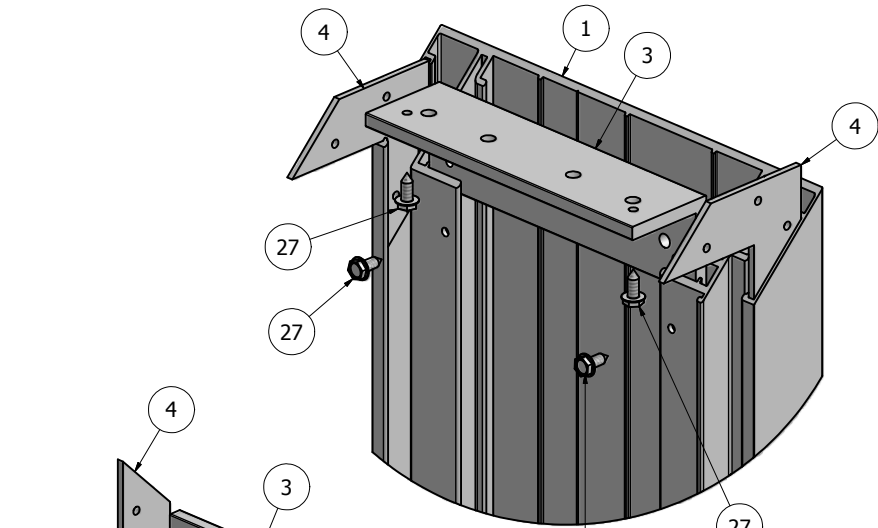
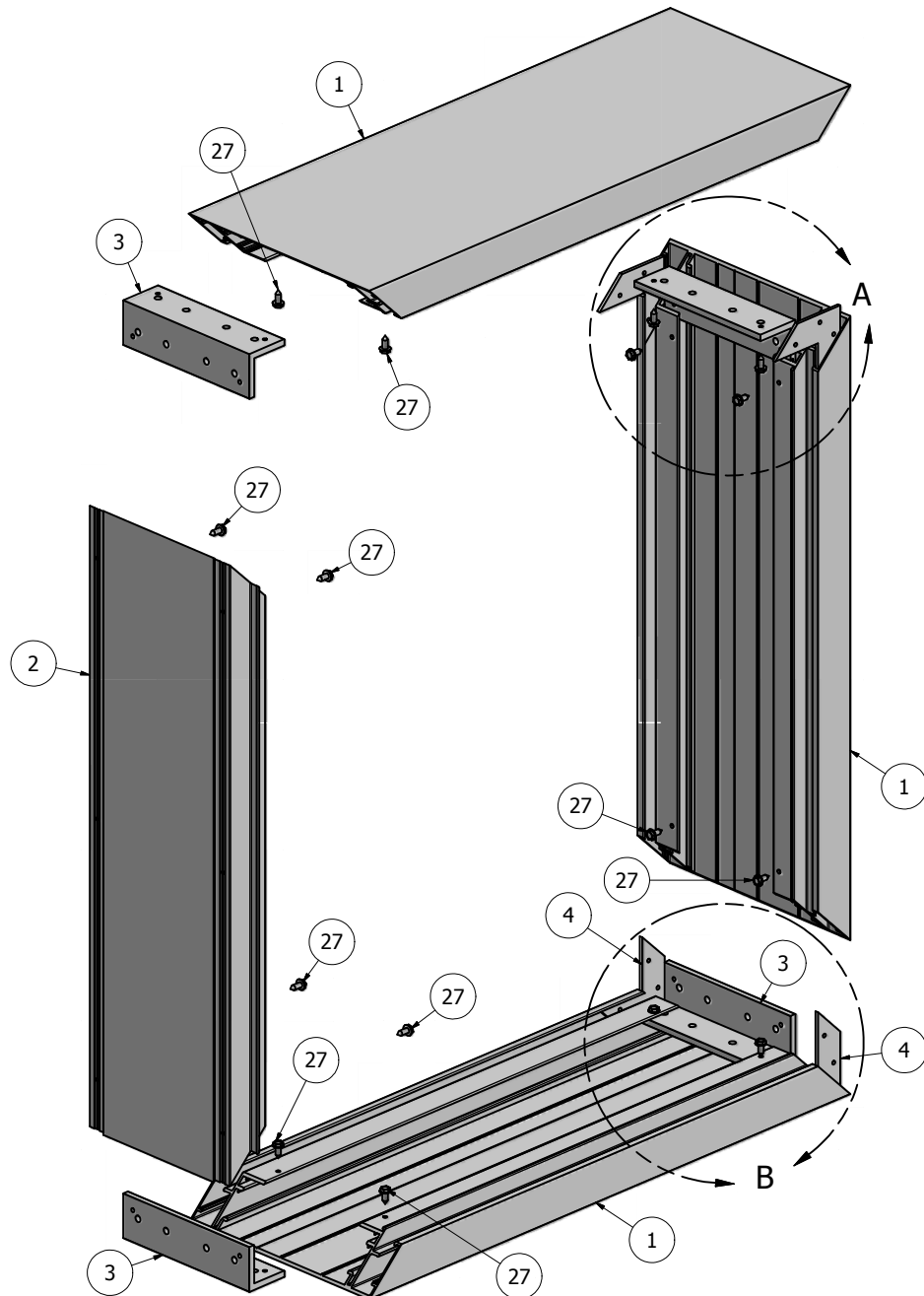

**NOTE: PRE-CUT KITS ARE NOT PRE-DRILLED.**  
 (Holes shown in this drawing are for reference only.  
 Drilling of pilot holes are to be done by fabricator.)

THIS DRAWING WAS CREATED AT NO CHARGE TO ASSIST YOU IN VISUALIZING OUR PROPOSAL. THE DRAWING HEREIN IS THE PROPERTY OF SIGNCOMP. PERMISSION TO COPY OR REVISE THIS DRAWING OR TO USE THIS DRAWING FOR PRODUCTION IS STRICTLY PROHIBITED AND CAN ONLY BE COPIED, REVISED OR USED FOR PRODUCTION WITH THE EXPRESSED WRITTEN PERMISSION OF SIGNCOMP.

DRAWN	6/15/2010
Steve	
CHECKED	
QA	
MFG	
APPROVED	

<b>SignComp</b>		
TITLE		
1Part 2Part 9" Double Face Body - Assembly		
SIZE	DWG NO	REV
C	1923-28	
SCALE	SHEET 1 OF 1	