

TOP CROSS-SECTION VIEW

Ship To:
Sales Order#

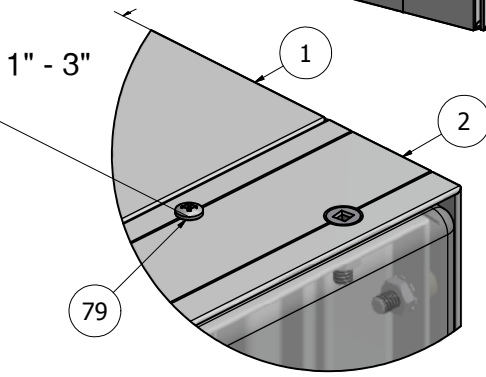
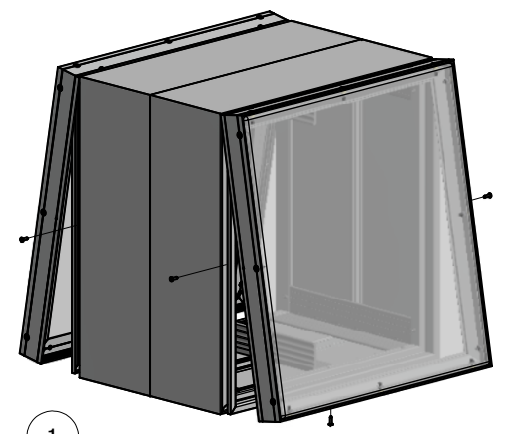

DETAIL A
FRAME CLOSED

NOTE: PRE-CUT KITS ARE NOT PRE-DRILLED.
(Holes shown in this drawing are for reference only.
Drilling of pilot holes are to be done by fabricator.)

PARTS LIST			
ITEM	PART #	DESCRIPTION	NOTES
1	K2009	Flat 2 Piece Double Face Body	Assembly
2	K2204	Flat Bleed Rigid Retainer	Assembly
79	5175	Hinge Screw - #10 x 5/8" Pan Head	Pre-drill 5/32" pilot hole every 36" o/c
80	5175	Closure Screw - #10 x 5/8" Pan Head	Pre-drill 5/32" pilot hole every 48" o/c

THIS DRAWING WAS CREATED AT NO CHARGE TO ASSIST YOU IN VISUALIZING OUR PROPOSAL. THE DRAWING HEREIN IS THE PROPERTY OF SIGNCOMP. PERMISSION TO COPY OR REVISE THIS DRAWING OR TO USE THIS DRAWING FOR PRODUCTION IS STRICTLY PROHIBITED AND CAN ONLY BE COPIED, REVISED OR USED FOR PRODUCTION WITH THE EXPRESSED WRITTEN PERMISSION OF SIGNCOMP.

DRAWING BY:	SBreihof	9/11/2013
Centroid X:	0.000 in	
Centroid Y:	0.000 in	
Principal Moments Ix:	0.000 in^4	
Principal Moments Iy:	0.000 in^4	
Section Modulus Ix:	0.000 in^3	
Section Modulus Iy:	0.000 in^3	

<h1>SignComp</h1>		TITLE
		Flat 2 Piece Double Face Body w/ Flat Bleed Rigid Retainer - Assembly
PART NO	K2009-2204	REV
SHEET 1 OF 1		

NOTE: THE FRAME ALIGNS TIGHT TO THE BODY, SHOWING NO REVEAL.

PARTS LIST			
ITEM	PART #	DESCRIPTION	NOTES
1	2009	Flat 2PC Double Face Body	Top & Bottom
2	2009	Flat 2PC Double Face Body	Sides
3	5909	Flat 2PC Double Face Body Corner Angle	One (1) per corner
4	5909	Flat 2PC Double Face Body Corner Angle	Notched by Other
13	5218	Corner Angle Screw	Pre-drill 5/32" pilot hole

Ship To:
Sales Order#

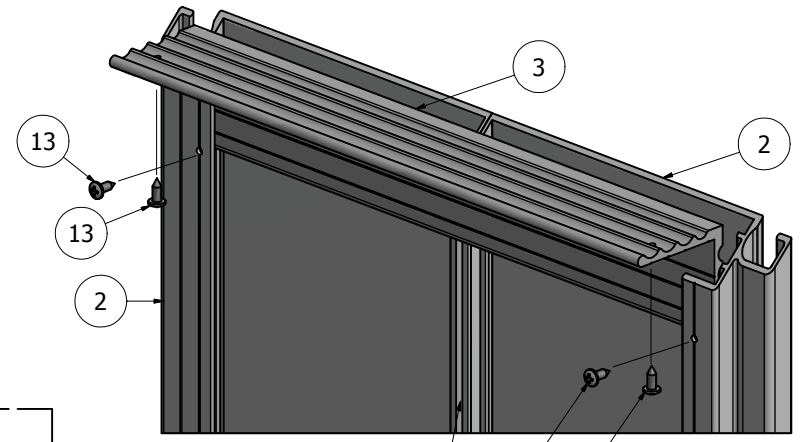
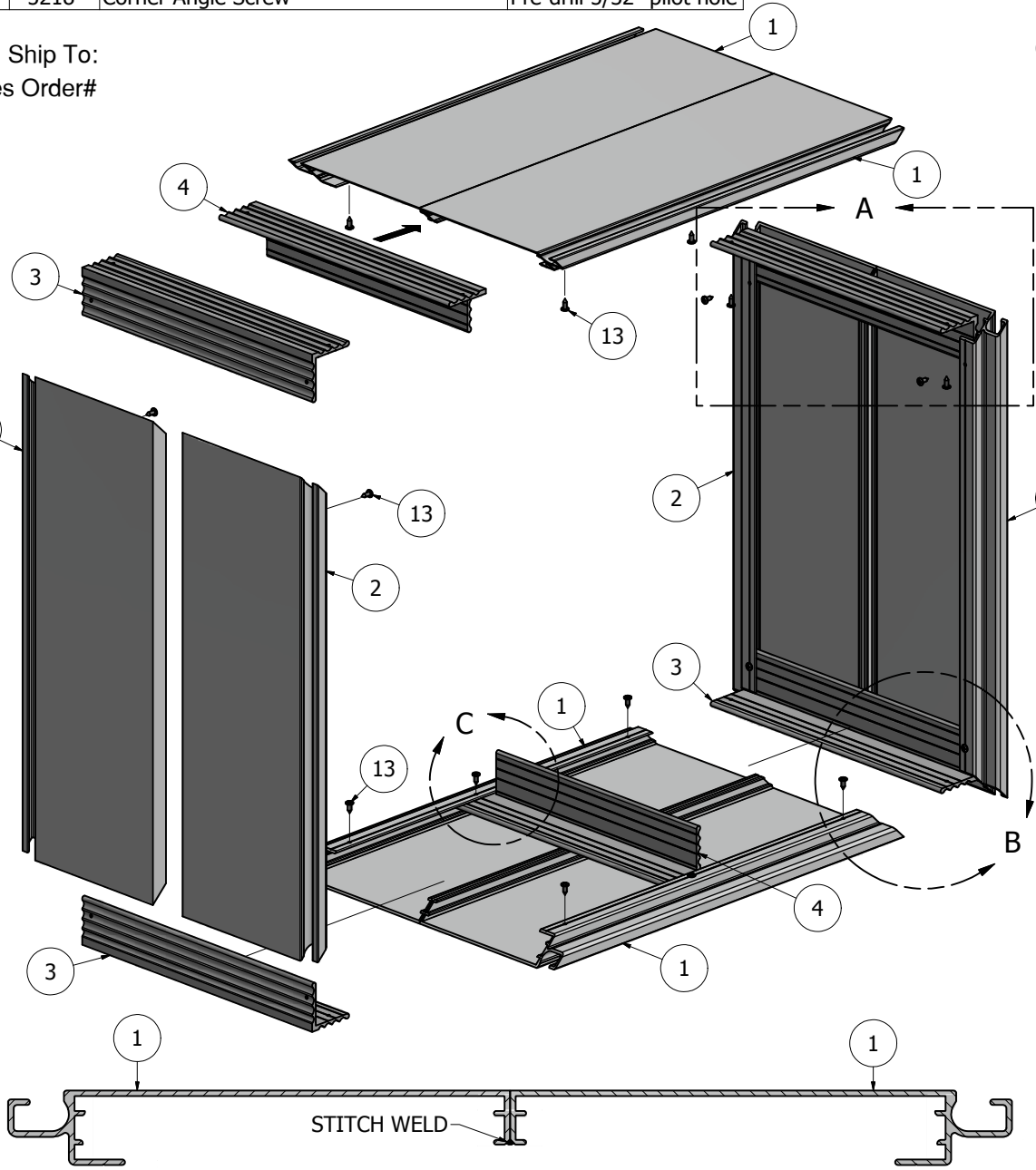

NOTE: Stitch weld the body joint then fill in the gaps between the welds with a bead of silicon.

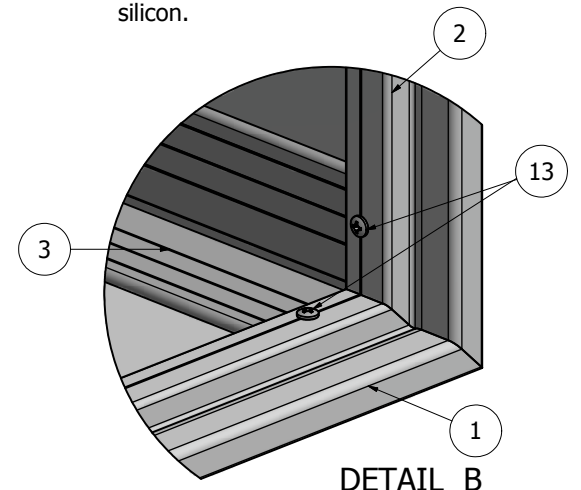

NOTE: PRE-CUT KITS ARE NOT PRE-DRILLED.
(Holes shown in this drawing are for reference only. Drilling of pilot holes are to be done by fabricator.)

THIS DRAWING WAS CREATED AT NO CHARGE TO ASSIST YOU IN VISUALIZING OUR PROPOSAL. THE DRAWING HEREIN IS THE PROPERTY OF SIGNCOMP. PERMISSION TO COPY OR REVISE THIS DRAWING OR TO USE THIS DRAWING FOR PRODUCTION IS STRICTLY PROHIBITED AND CAN ONLY BE COPIED, REVISED OR USED FOR PRODUCTION WITH THE EXPRESSED WRITTEN PERMISSION OF SIGNCOMP.		SignComp
DRAWING BY: SBreihof	8/14/2013	
Centroid X: 0.000 in	Centroid Y: 0.000 in	TITLE
Principal Moments Ix: 0.000 in ⁴	Principal Moments Iy: 0.000 in ⁴	Flat 2PC Double Face Body - Assembly
Section Modulus Ix: 0.000 in ³	Section Modulus Iy: 0.000 in ³	PART NO
		K2009
		REV
		SHEET 1 OF 2

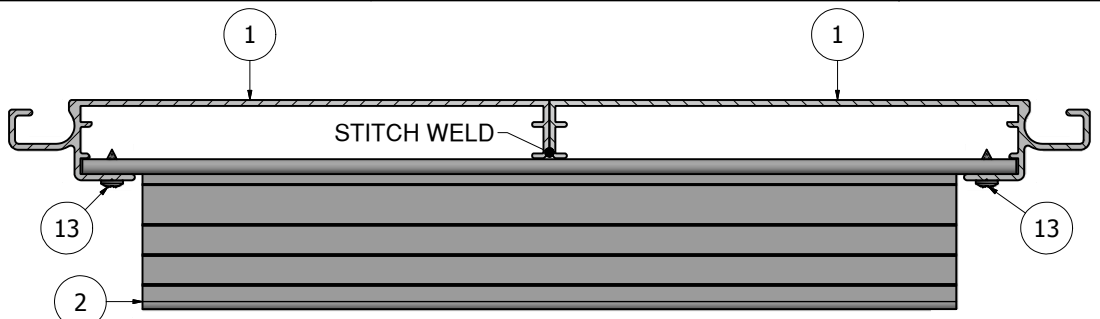

TOP & BOTTOM CROSS-SECTION VIEW
AT BODY BRACE

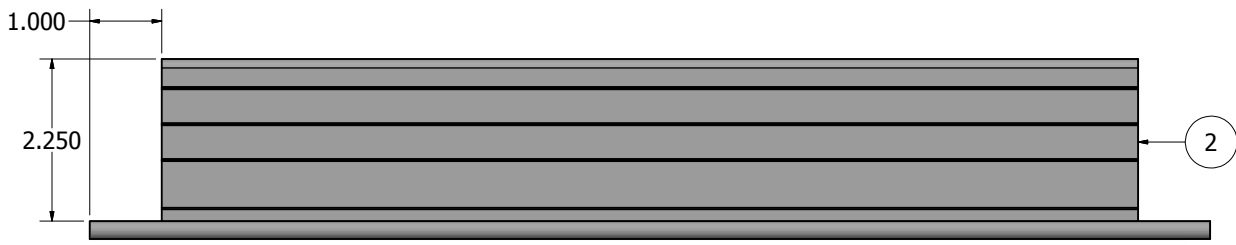

NOTE: NOTCH BOTH ENDS OF THE ANGLE ABOVE TO BYPASS THE INNER BODY FLANGES. THIS SERVES AS A BRACE TO PROVIDE ADDITIONAL SUPPORT TO THE JOINED BODY SECTIONS.

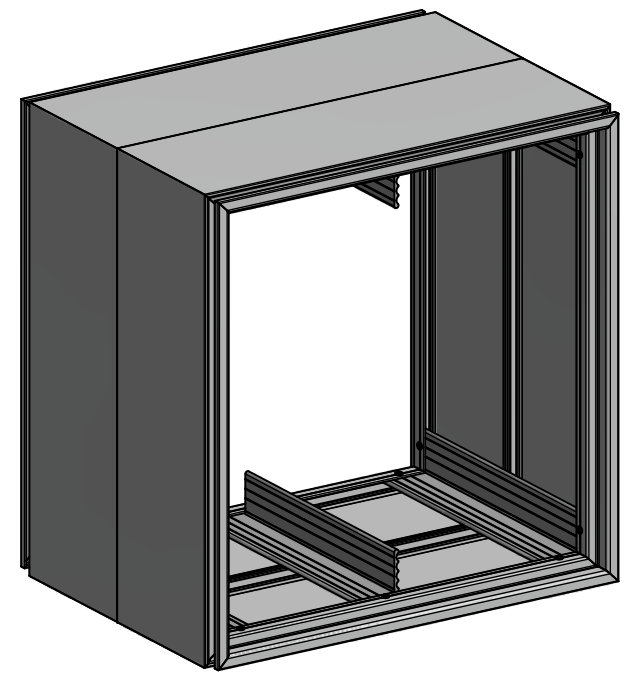

NOTE: BRACES SHOULD BE SPACED A MIN. OF 48" ON CENTER.

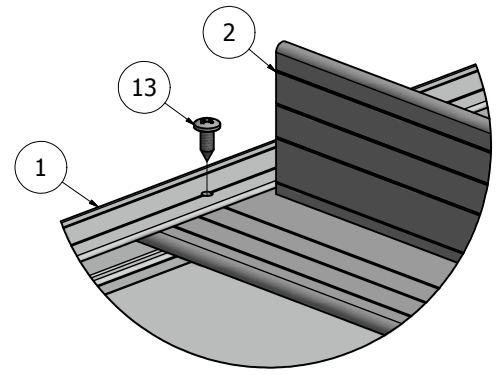
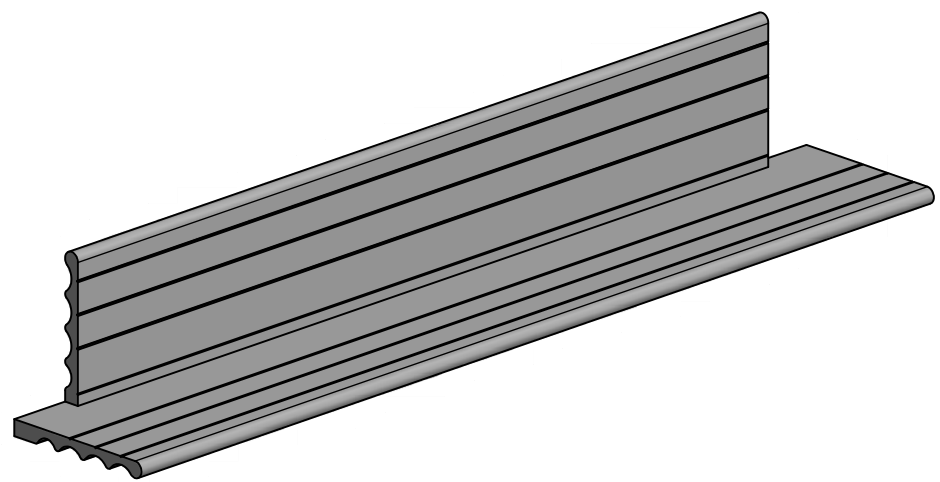

DETAIL C

THIS DRAWING WAS CREATED AT NO CHARGE TO ASSIST YOU IN VISUALIZING OUR PROPOSAL. THE DRAWING HEREIN IS THE PROPERTY OF SIGNCOMP. PERMISSION TO COPY OR REVISE THIS DRAWING OR TO USE THIS DRAWING FOR PRODUCTION IS STRICTLY PROHIBITED AND CAN ONLY BE COPIED, REVISED OR USED FOR PRODUCTION WITH THE EXPRESSED WRITTEN PERMISSION OF SIGNCOMP.

DRAWING BY:	SBreihof	8/14/2013	SignComp
Centroid X:	0.000 in		
Centroid Y:	0.000 in		
Principal Moments Ix:	0.000 in ⁴		
Principal Moments Iy:	0.000 in ⁴		
Section Modulus Ix:	0.000 in ³		TITLE
Section Modulus Iy:	0.000 in ³		Flat 2PC Double Face Body - Assembly
PART NO			REV
K2009			
SHEET 2 OF 2			

PARTS LIST			
ITEM	PART	DESCRIPTION	NOTES
1	2009	Flat 2PC Double Face Body	All Sides
2	5909	Flat 2PC Double Face Body Corner Angle	Notched by Other
13	5218	Corner Angle Screw	Pre-drill 5/32" pilot hole

PARTS LIST			
ITEM	PART#	DESCRIPTION	NOTES
1	2204	Flat Bleed Retro Frame	Top & Bottom
2	2204	Flat Bleed Retro Frame	Sides
3	5210	Corner Key	
82	5168	Flat Bleed Retainer Screw	#8 x 1/2" Countersink - Predrill & Countersink 1/8" hole

Ship To:
Sales Order#

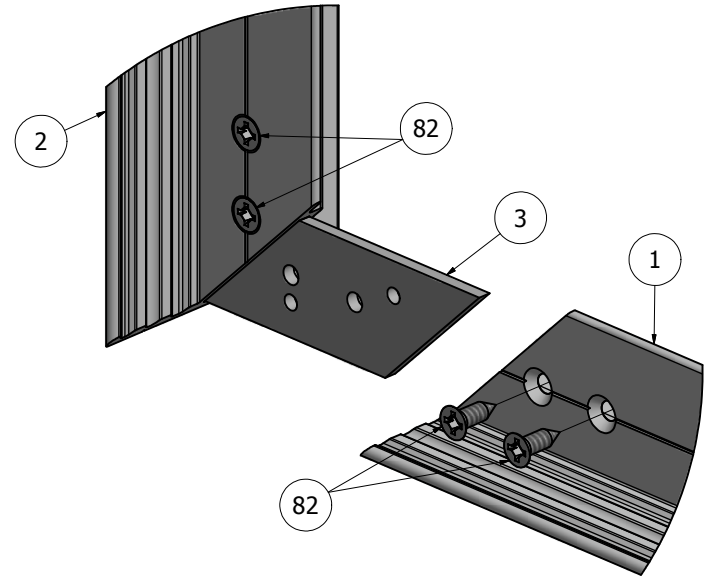
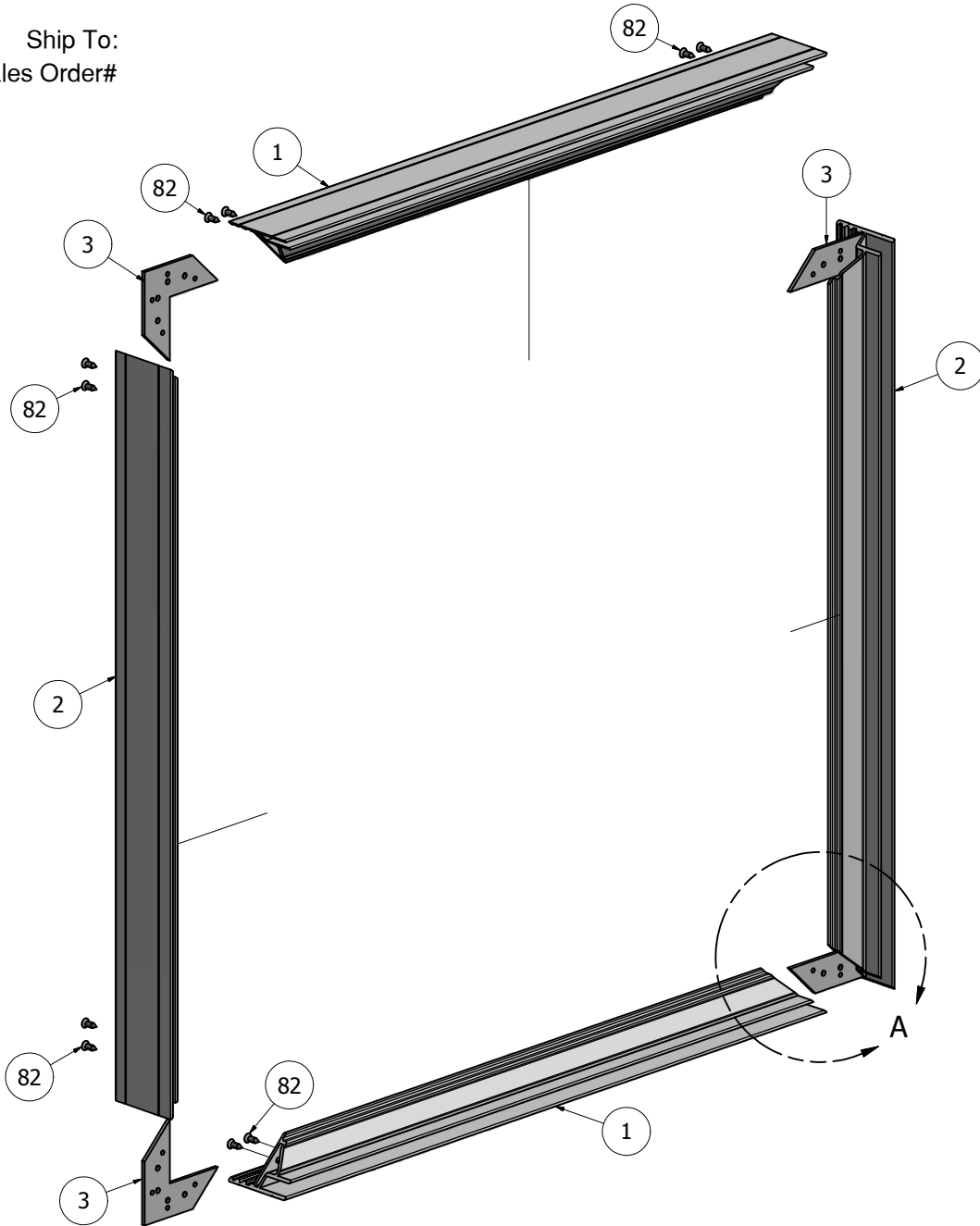

DETAIL A
BACK SIDE

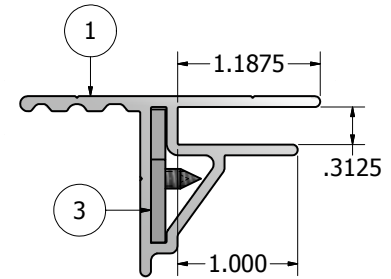

CROSS-SECTION VIEW

NOTE: PRE-CUT KITS ARE NOT PRE-DRILLED.
(Holes shown in this drawing are for reference only.
Drilling of pilot holes are to be done by fabricator.)

THIS DRAWING WAS CREATED AT NO CHARGE TO ASSIST YOU IN VISUALIZING OUR PROPOSAL. THE DRAWING HEREIN IS THE PROPERTY OF SIGNCOMP. PERMISSION TO COPY OR REVISE THIS DRAWING OR TO USE THIS DRAWING FOR PRODUCTION IS STRICTLY PROHIBITED AND CAN ONLY BE COPIED, REVISED OR USED FOR PRODUCTION WITH THE EXPRESSED WRITTEN PERMISSION OF SIGNCOMP.

DRAWING BY:	SBreihof	8/27/2013	SignComp
Centroid X:	0.000 in		
Centroid Y:	0.000 in		Flat Bleed Rigid Retainer
Principal Moments Ix:	0.000 in ⁴		PART NO
Principal Moments Iy:	0.000 in ⁴		K2204
Section Modulus Ix:	0.000 in ³		REV
Section Modulus Iy:	0.000 in ³		

PARTS LIST			
ITEM	PART#	DESCRIPTION	NOTES
1	K2204	Flat Bleed Rigid Retainer	Assembly
1.3	5210	Corner Key	
1.4	5168	Flat Bleed Rigid Retainer Screw	
2		3/16" Polycarbonate Pan Face	By Other
3	5285	Rigid Face Hardware	Assembly - Approx. 18" o/c
3.1		1/4" x 20 Lock Nut	
3.2		Nylon Bushing	
3.3		1/4" x 20 x 1" UNC Square Recessed Flat Countersunk Head Machine Screw - Type III	

Ship To:
Sales Order#

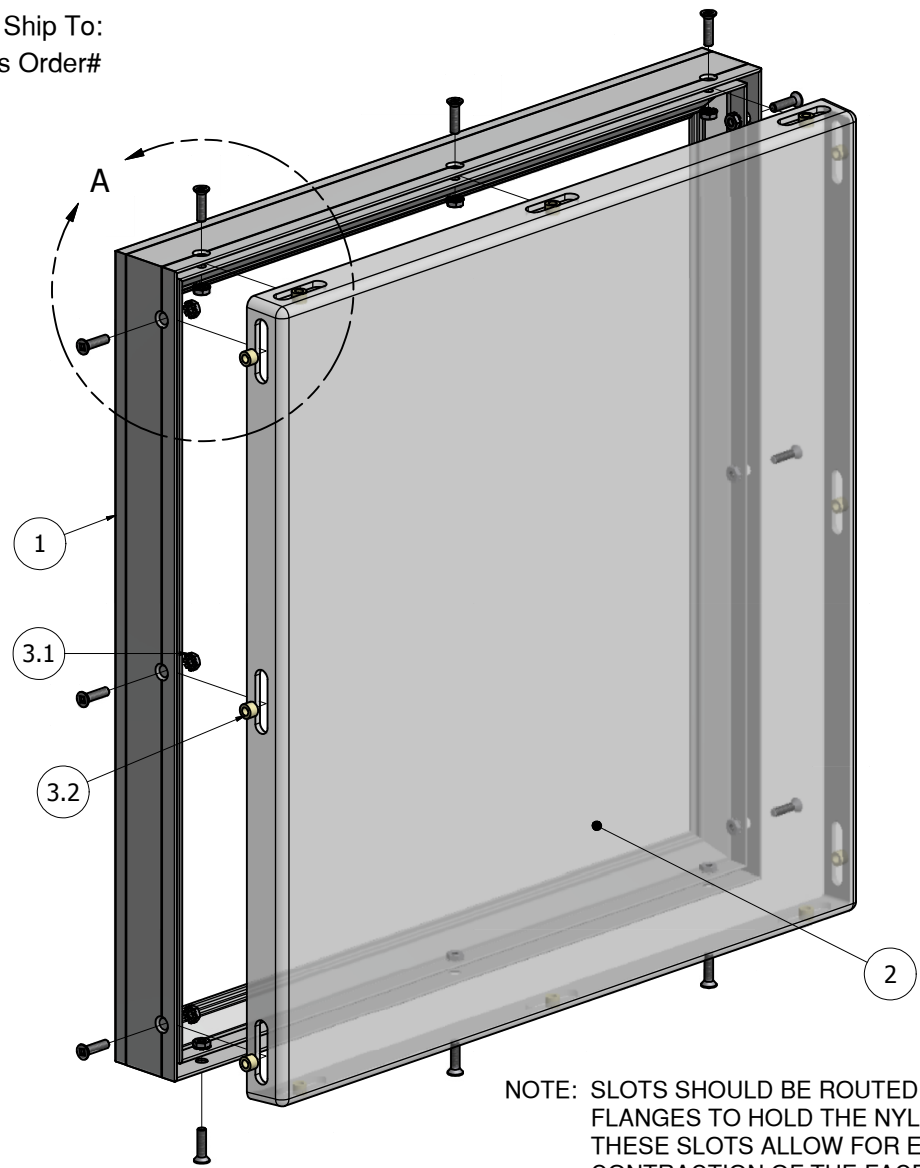

NOTE: SLOTS SHOULD BE ROUTED INTO THE FACE FLANGES TO HOLD THE NYLON BUSHINGS. THESE SLOTS ALLOW FOR EXPANSION AND CONTRACTION OF THE FACE MATERIAL.

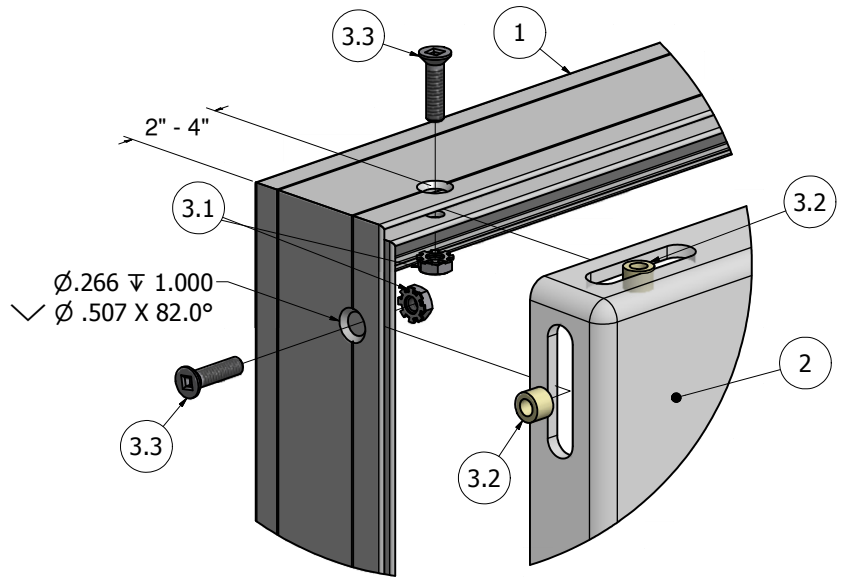

DETAIL A-1

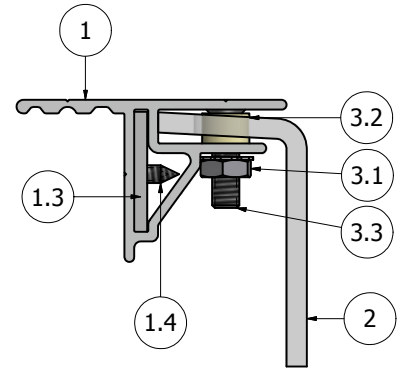

CROSS-SECTION VIEW

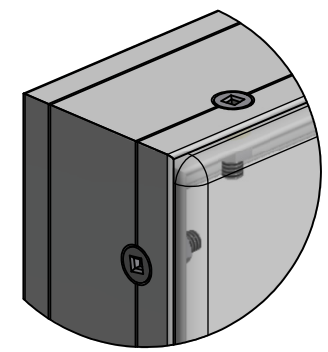

DETAIL A-2
ASSEMBLED

NOTE: PRE-CUT KITS ARE NOT PRE-DRILLED.
(Holes shown in this drawing are for reference only. Drilling of pilot holes are to be done by fabricator.)

DRAWING BY: SBreihof 8/27/2013		SignComp
Centroid X: 0.000 in	Centroid Y: 0.000 in	
Principal Moments Ix: 0.000 in ⁴		Flat Bleed Rigid Retainer Face - Assembly
Principal Moments Iy: 0.000 in ⁴		
Section Modulus Ix: 0.000 in ³		K2204-FACE
Section Modulus Iy: 0.000 in ³		
SHEET 1 OF 1		