

ITEM	PART #	DESCRIPTION	NOTES
1	K2041	Flat Retro Body	Assembly
2	K2107-2121	Flat Bleed Retro Frame II / Bleed Cover	Assembly
79	5178	Hinge Screw - #10 x 5/8" pancake head	Pre-drill 5/32" - Top 36" o/c
80	5178	Closure Screw - #10 x 5/8" pancake head	Pre-drill 5/32" - Bottom every 48" o/c

NOTE: PRE-CUT KITS ARE NOT PRE-DRILLED.
 (Holes shown in this drawing are for reference only.
 Drilling of pilot holes are to be done by fabricator.)

Ship To:
 Sales Order #

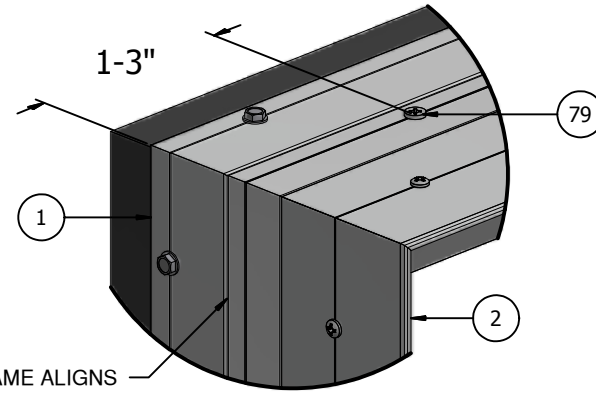
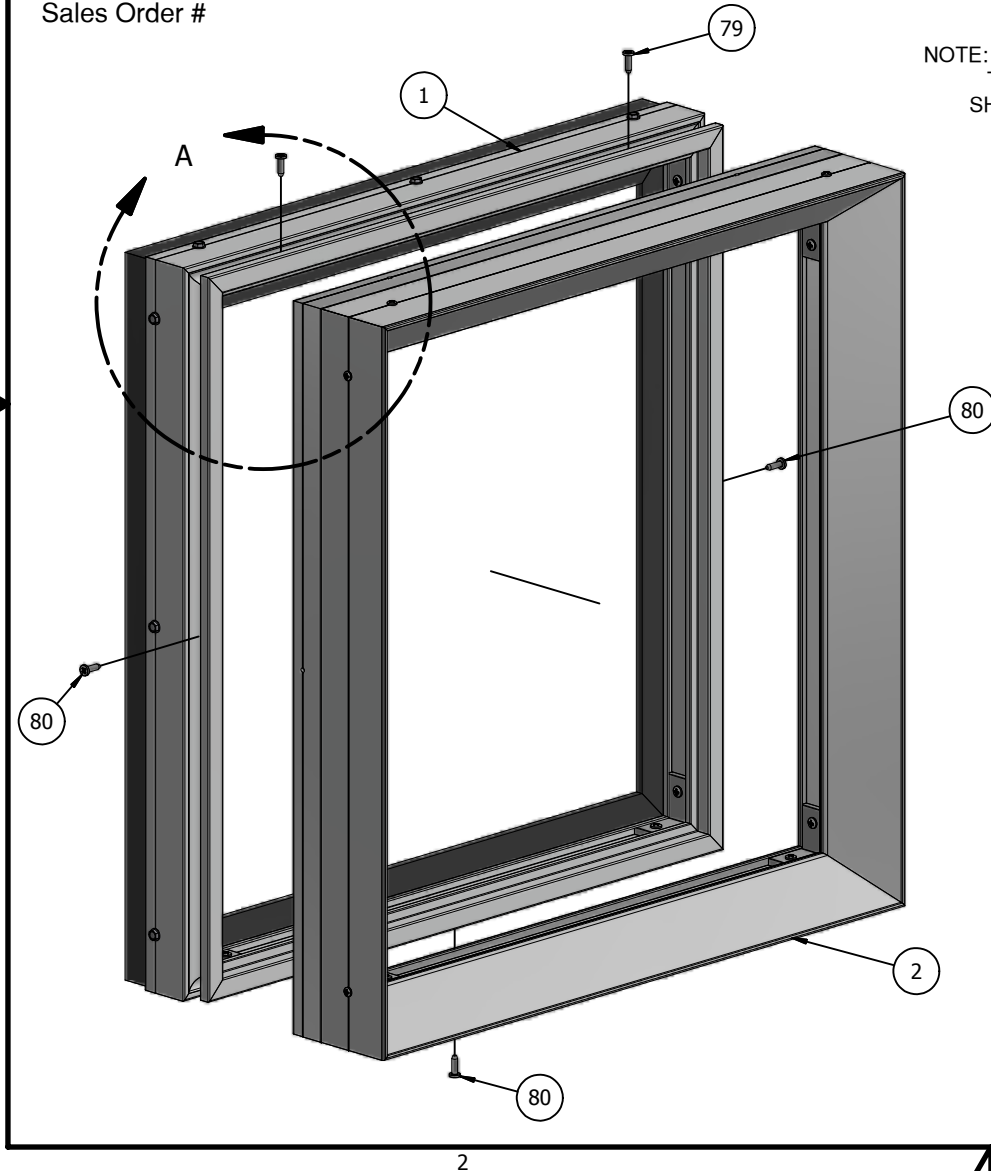

DETAIL A
 FRAME CLOSED

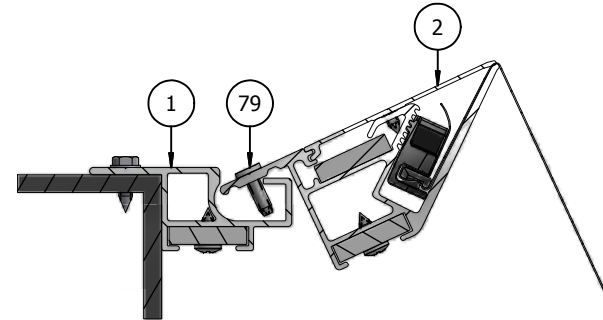

TOP CROSS-SECTION VIEW

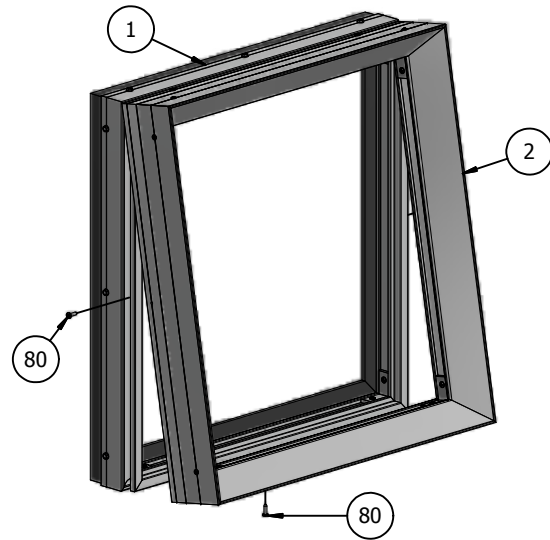

THIS DRAWING WAS CREATED AT NO CHARGE TO ASSIST YOU IN VISUALIZING OUR PROPOSAL. THE DRAWING HEREIN IS THE PROPERTY OF SIGNCOMP. PERMISSION TO COPY OR REVISE THIS DRAWING OR TO USE THIS DRAWING FOR PRODUCTION IS STRICTLY PROHIBITED AND CAN ONLY BE COPIED, REVISED OR USED FOR PRODUCTION WITH THE EXPRESSED WRITTEN PERMISSION OF SIGNCOMP.

Part Name: **Flat Retro Body w/ Flat Bleed Retro Frm II & Bleed Cvr1 of 1** Sheet: **A** Size: **A**

Part Number: **K2041-2107-21** Revision: **2/12/2015** Date: **2/12/2015** Drawing By: **SBreihof**



PARTS LIST			
ITEM	PART #	DESCRIPTION	NOTES
1		Angle Frame or Existing Structure	Not provided by SignComp
2	2041	Flat Retro Body	Top & Bottom
3	2041	Flat Retro Body	Sides
4	5305	Frame Corner Angle	One (1) per corner
5		Attachment Fastener	By Other
13	5218	Corner Angle Screw	Pre-drill 5/32" hole

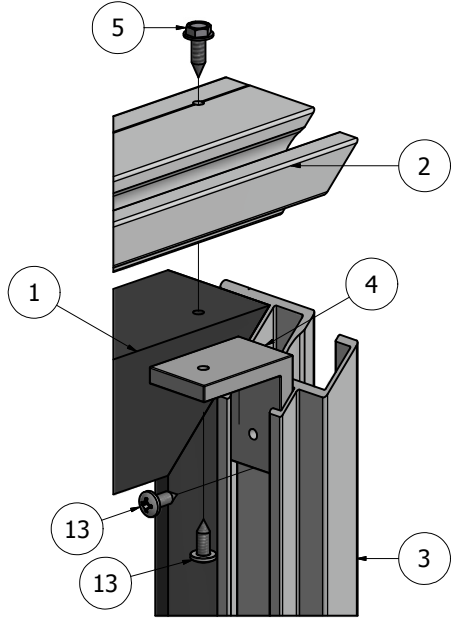
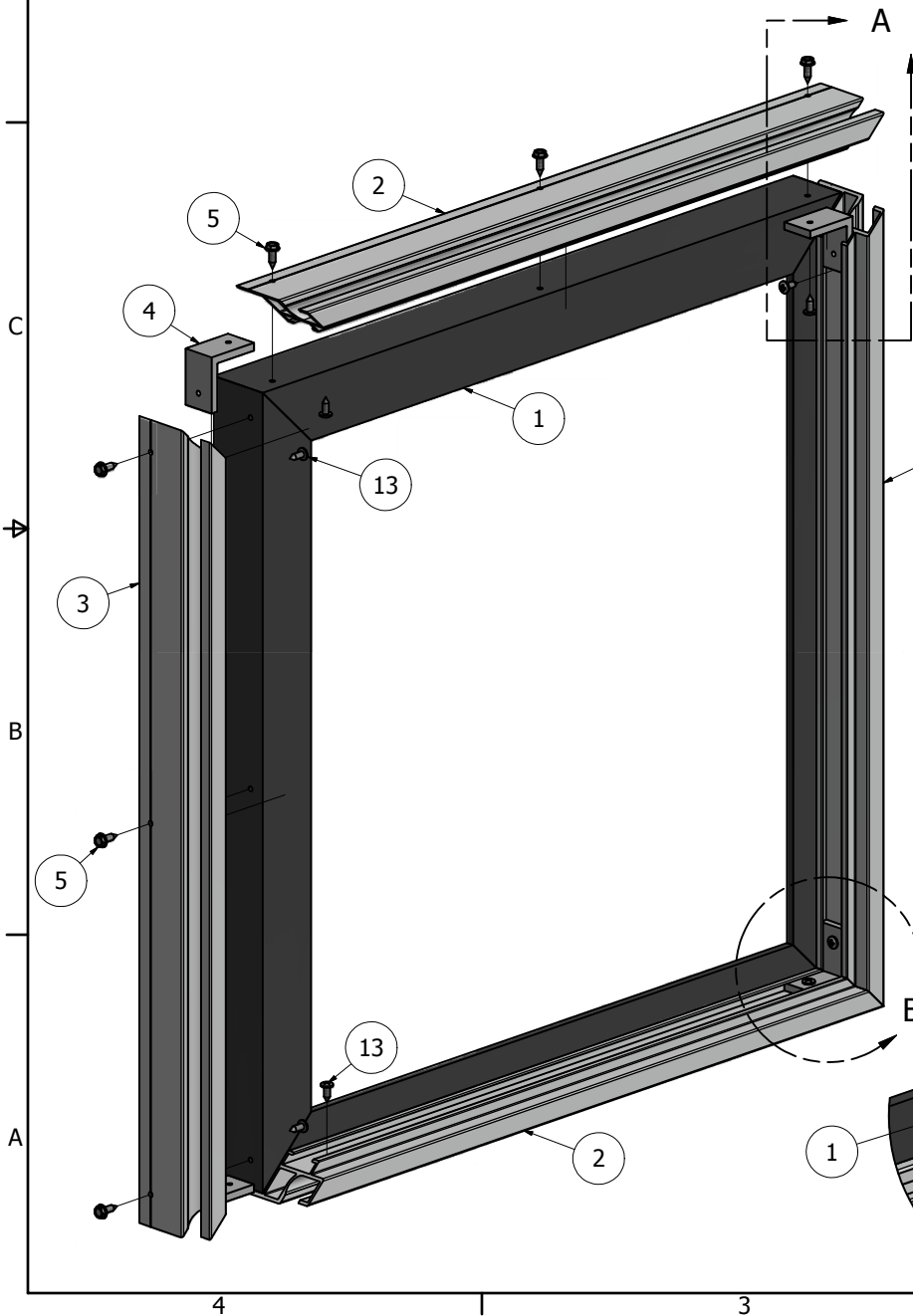

DETAIL A-1

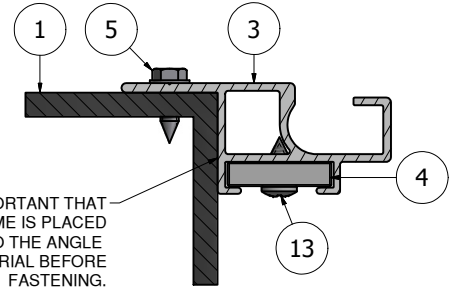

CROSS-SECTION VIEW

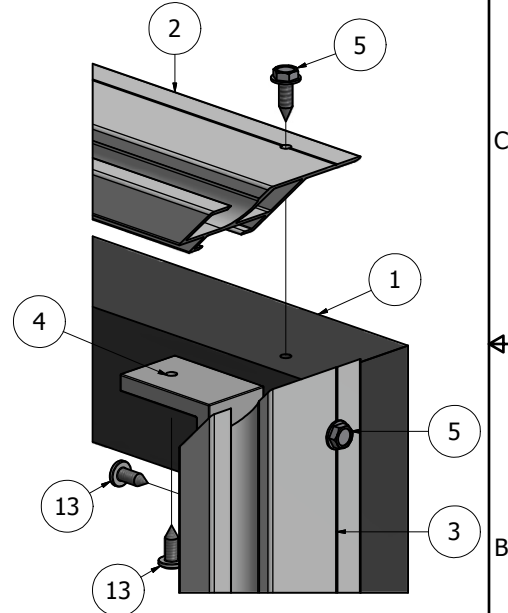

DETAIL A-2

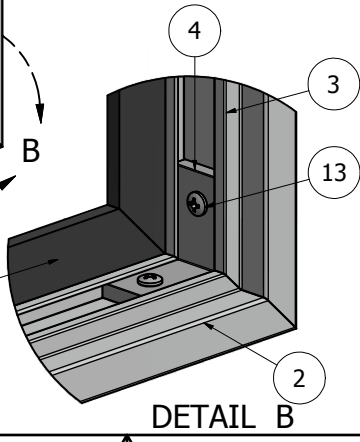

DETAIL B

NOTE: PRE-CUT KITS ARE NOT PRE-DRILLED.
 (Holes shown in this drawing are for reference only.
 Drilling of pilot holes are to be done by fabricator.)

THIS DRAWING WAS CREATED AT NO CHARGE TO ASSIST YOU IN VISUALIZING OUR PROPOSAL. THE DRAWING HEREIN IS THE PROPERTY OF SIGNCOMP. PERMISSION TO COPY OR REVISE THIS DRAWING OR TO USE THIS DRAWING FOR PRODUCTION IS STRICTLY PROHIBITED AND CAN ONLY BE COPIED, REVISED OR USED FOR PRODUCTION WITH THE EXPRESSED WRITTEN PERMISSION OF SIGNCOMP.

DRAWING BY:	SBreihof	8/15/2013
Centroid X:	0.000 in	
Centroid Y:	0.000 in	
Principal Moments Ix:	0.000 in ⁴	
Principal Moments Iy:	0.000 in ⁴	
Section Modulus Ix:	0.000 in ³	
Section Modulus Iy:	0.000 in ³	

SignComp		TITLE
		Flat Retro Body - Assembly
PART NO	K2041	REV
		SHEET 1 OF 1

ITEM	PART #	DESCRIPTION	NOTES
1	2107	Flat Bleed Retro Frame II	Top & Bottom
2	2107	Flat Bleed Retro Frame II	Sides
3	5305	Frame Corner Angle	Two (2) per corner
13	5218	Corner Angle Screw	#10 x 1/2" pan head tapping

Ship To:
Sales Order #

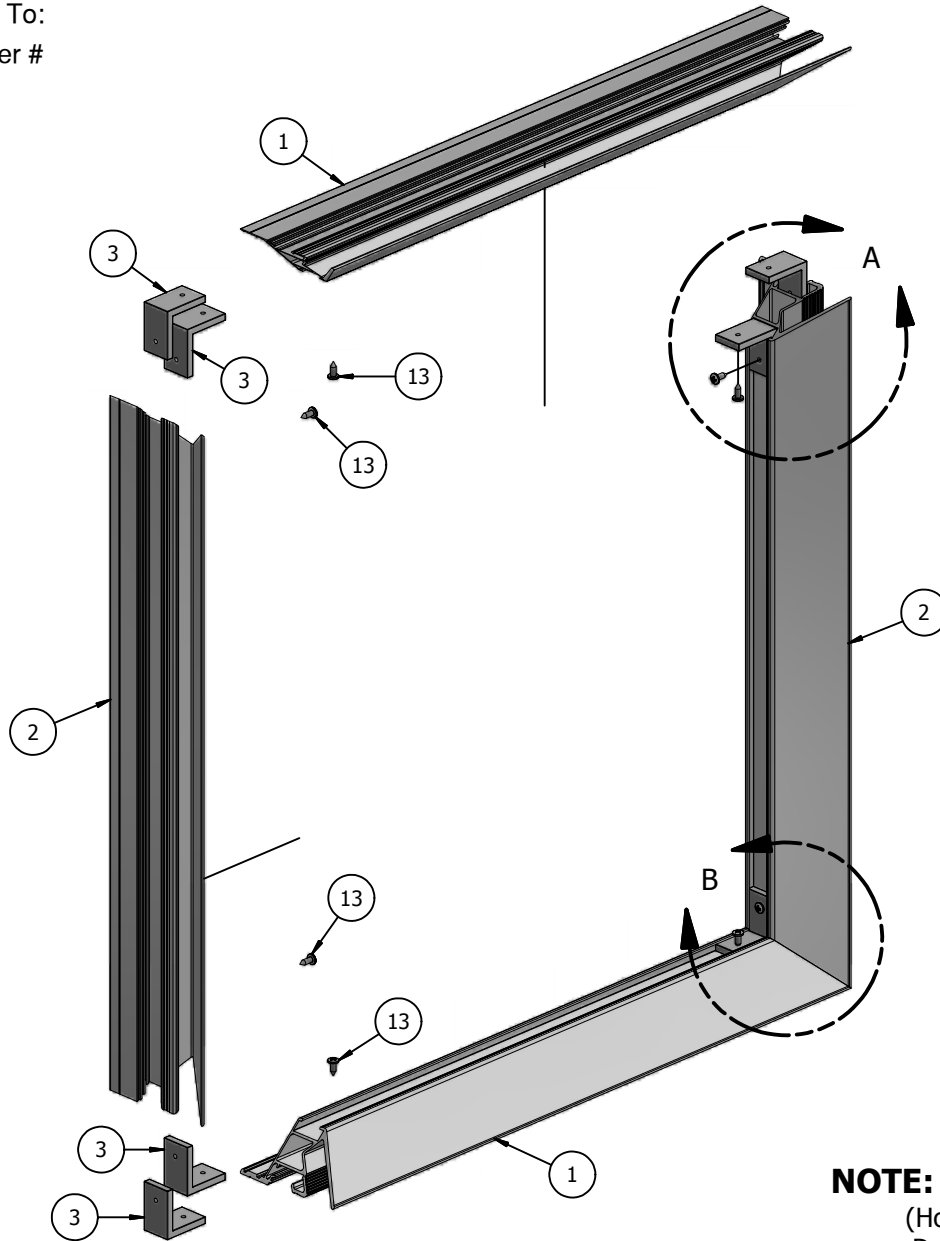

THE OUTER FRAME
CORNER ANGLE FLOATS
IN THE FRAME FOR
ALIGNMENT.

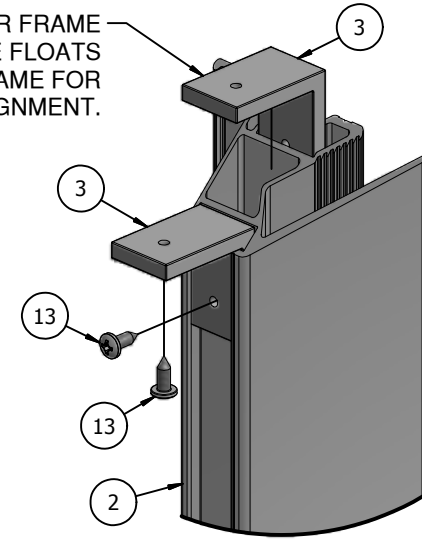

DETAIL A

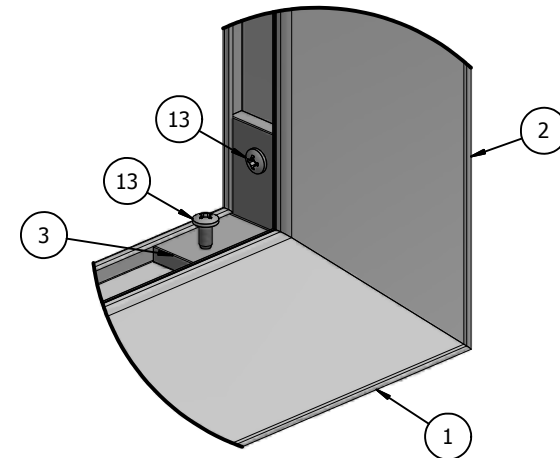

DETAIL B

NOTE: PRE-CUT KITS ARE NOT PRE-DRILLED.

(Holes shown in this drawing are for reference only.
Drilling of pilot holes are to be done by fabricator.)

THIS DRAWING WAS CREATED AT NO CHARGE TO ASSIST YOU IN VISUALIZING OUR PROPOSAL. THE DRAWING HEREIN IS THE PROPERTY OF SIGNCOMP. PERMISSION TO COPY OR REVISE THIS DRAWING OR TO USE THIS DRAWING FOR PRODUCTION IS STRICTLY PROHIBITED AND CAN ONLY BE COPIED, REVISED OR USED FOR PRODUCTION WITH THE EXPRESSED WRITTEN PERMISSION OF SIGNCOMP.

Part Name: Flat Bleed Retro Frame II - Assembly

Part Number: K2107

Revision:

Date: 1/30/2015

Drawing By: SBreihof

Sheet: 1 of 1

Size: A

SignComp

ITEM	PART #	DESCRIPTION	NOTES
1	2107	Flat Bleed Retro Frame II	Assembly
2	2121	Flat Bleed Retro Cover	All Sides
12	5195	Cover Screw	#8x5/16" Pre-drill 1/8" hole

NOTE: PRE-CUT KITS ARE NOT PRE-DRILLED.

(Holes shown in this drawing are for reference only.
Drilling of pilot holes are to be done by fabricator.)

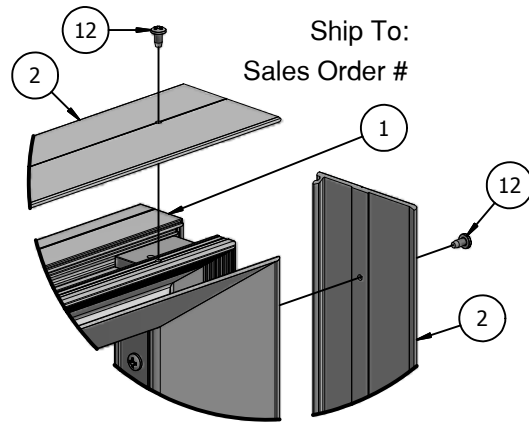
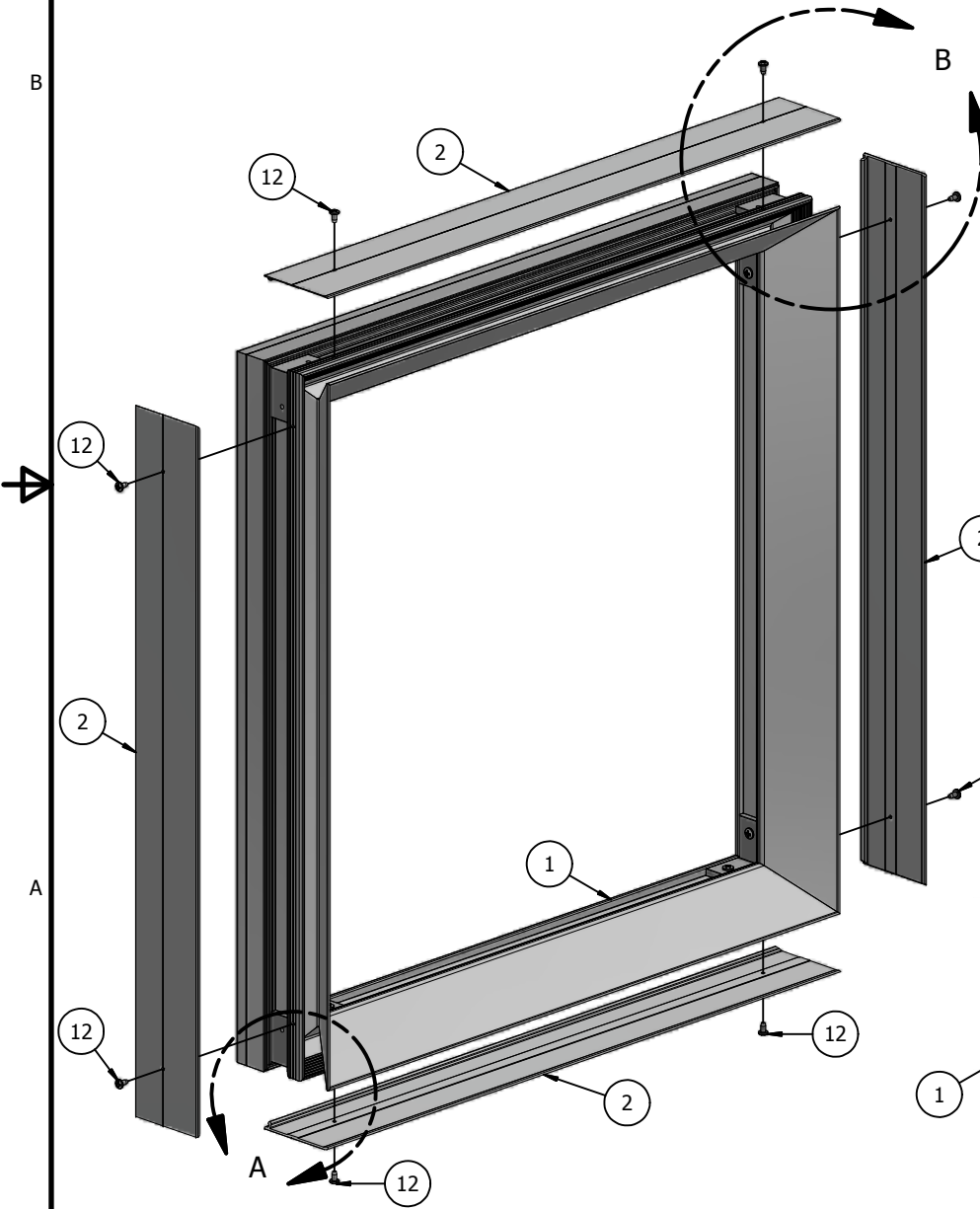

DETAIL B

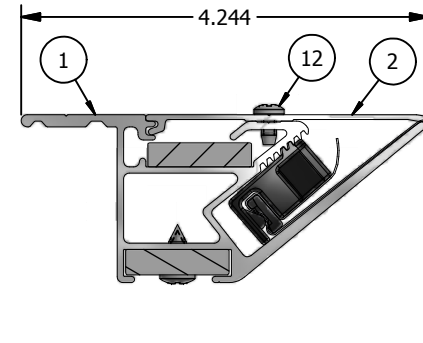

ASSEMBLY CROSS-SECTION

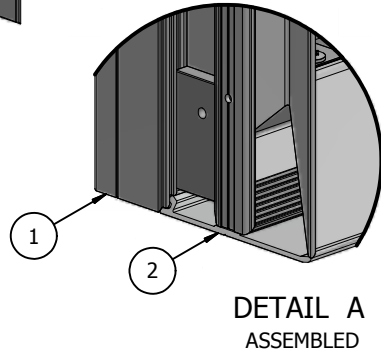

DETAIL A
ASSEMBLED

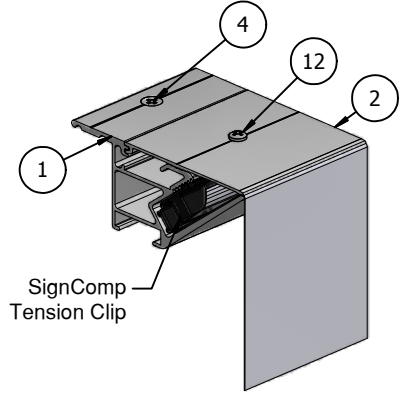

SignComp
Tension Clip

THIS DRAWING WAS CREATED AT NO CHARGE TO ASSIST YOU IN VISUALIZING OUR PROPOSAL. THE DRAWING HEREIN IS THE PROPERTY OF SIGNCOMP. PERMISSION TO COPY OR REVISE THIS DRAWING OR TO USE THIS DRAWING FOR PRODUCTION IS STRICTLY PROHIBITED AND CAN ONLY BE COPIED, REVISED OR USED FOR PRODUCTION WITH THE EXPRESSED WRITTEN PERMISSION OF SIGNCOMP.

Part Name:	Flat Bleed Retro Frame II/Bleed Cover - Assembly
Part Number:	K2107-21
Revision:	
Date:	1/30/2015
Sheet:	1 of 1
Size:	A
Sheet:	1 of 1
Drawing By:	SBreihof

SignComp