

PARTS LIST			
ITEM	PART#	DESCRIPTION	NOTES
1	1291	Series 3 Single Face Access Body	Top & Bottom
2	1291	Series 3 Single Face Access Body	Sides
3	Back Panel	.063 Aluminum Back Panel	By Other
4	5338	Series 3 Single Face Access Body Corner Angle	One (1) per body corner
60	5270	Access body Corner Screw	See hole detail

Ship To:
Sales Order #

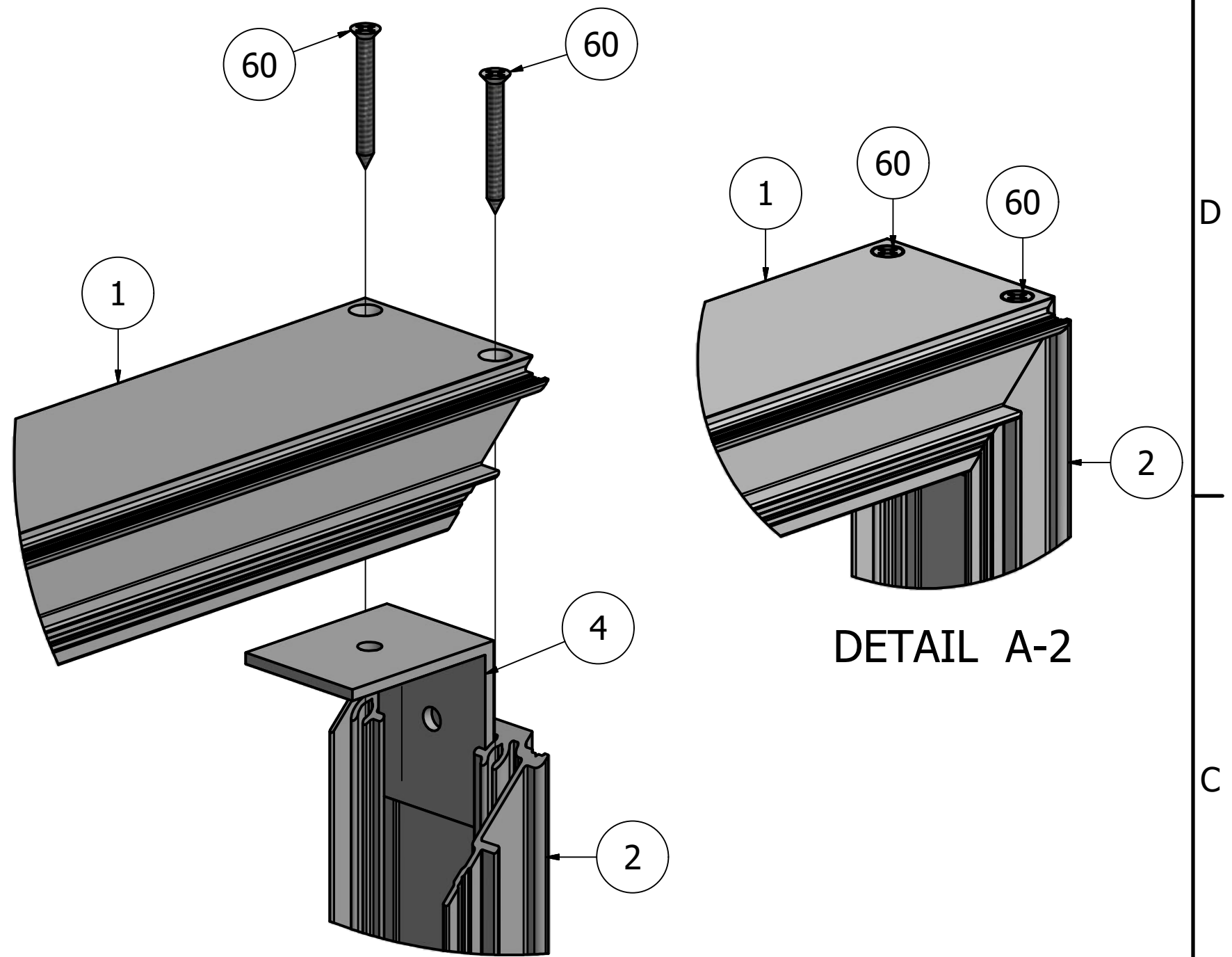

DETAIL A-1

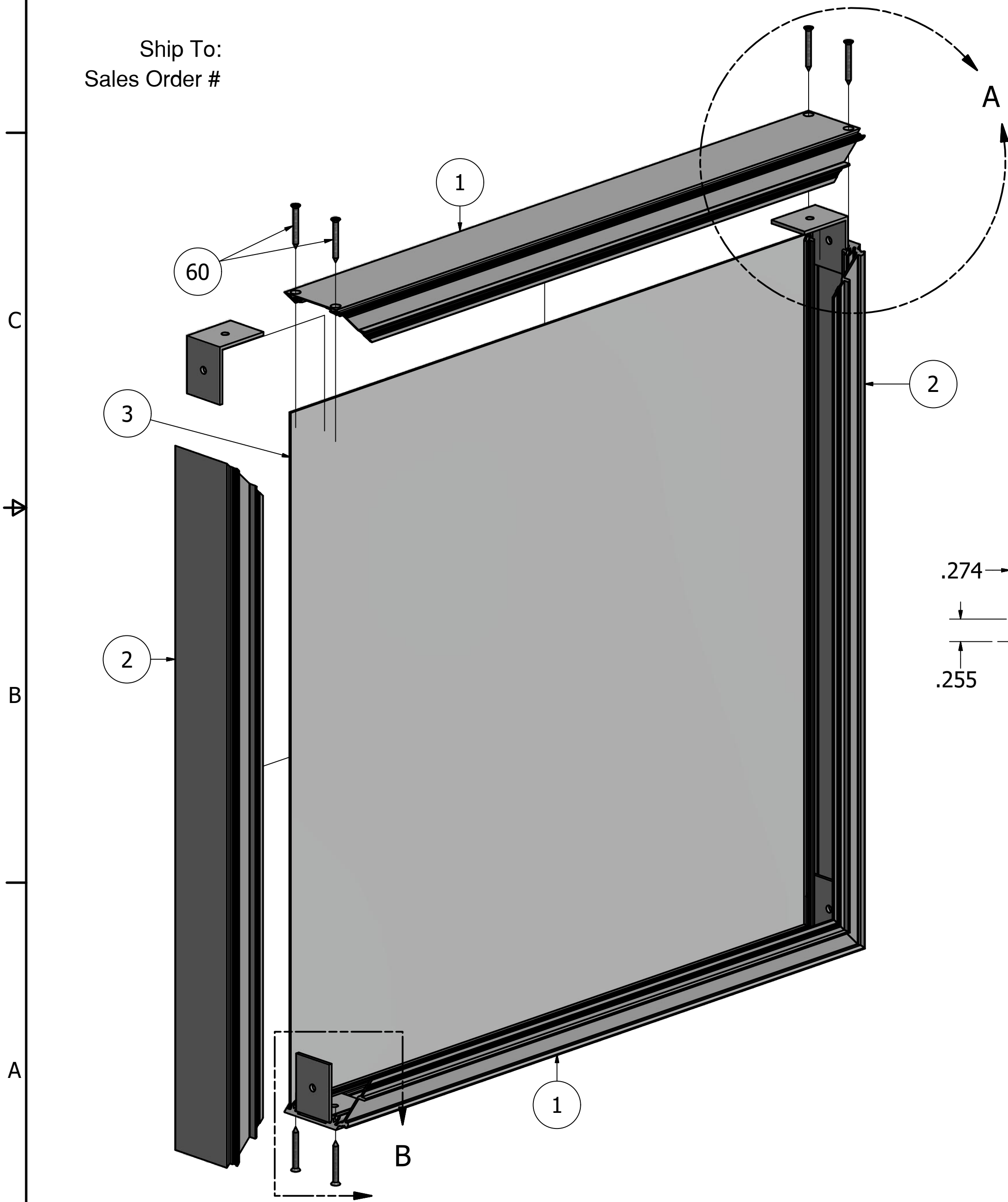
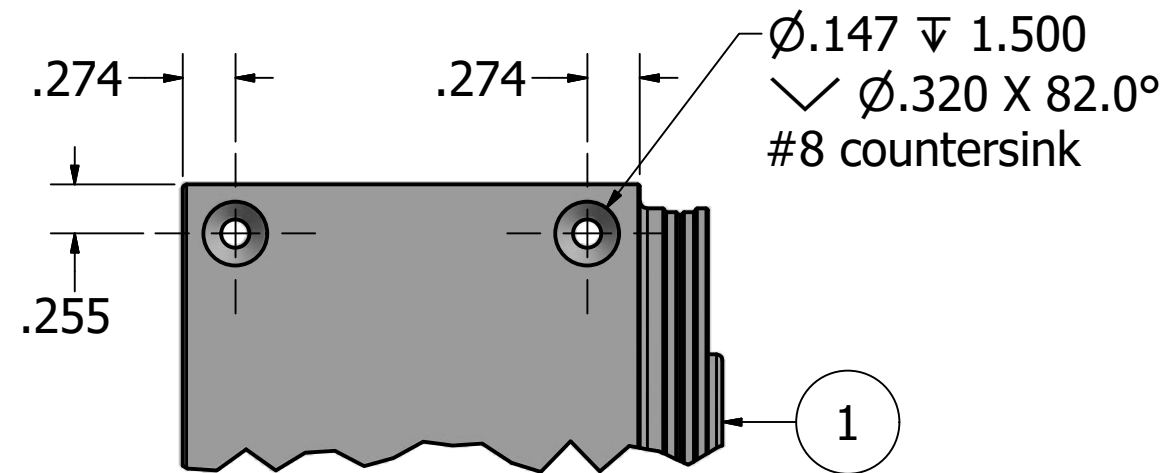

HOLE DETAIL
DRILLED BY OTHER

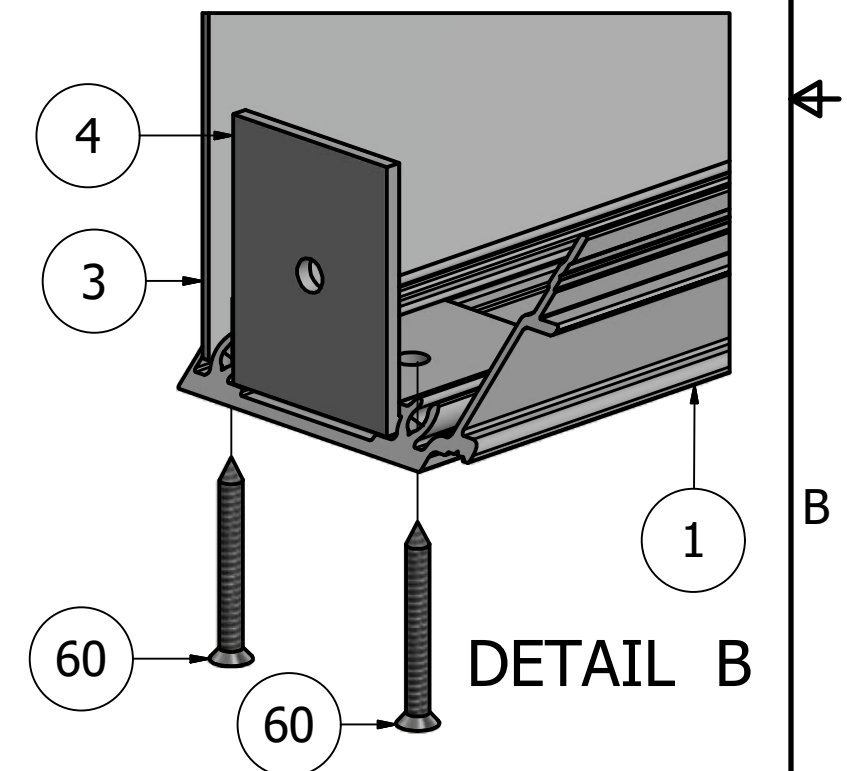

DETAIL B

NOTE: PRE-CUT KITS ARE NOT PRE-DRILLED.
(Holes shown in this drawing are for reference only.
Drilling of pilot holes are to be done by fabricator.)

THIS DRAWING WAS CREATED AT NO CHARGE TO ASSIST YOU IN VISUALIZING OUR PROPOSAL. THE DRAWING HEREIN IS THE PROPERTY OF SIGNCOMP. PERMISSION TO COPY OR REVISE THIS DRAWING OR TO USE THIS DRAWING FOR PRODUCTION IS STRICTLY PROHIBITED AND CAN ONLY BE COPIED, REVISED OR USED FOR PRODUCTION WITH THE EXPRESSED WRITTEN PERMISSION OF SIGNCOMP.			SignComp	
DRAWN	SBreihof	9/6/2012		
	Centroid X:	0.000 in	Series 3 - Single Face Access Body - Assembly	
	Centroid Y:	0.000 in		
	Principal Moments Ix:	0.000 in ⁴	DWG NO	REV
	Principal Moments Iy:	0.000 in ⁴	K1291	
	Section Modulus Ix:	0.000 in ³	SHEET 1 OF 1	
	Section Modulus Iy:	0.000 in ³		

PARTS LIST			
ITEM	PART #	DESCRIPTION	NOTES
1	1291	Single Face Access Body	Assembly
2	1668	Insert Divider	
3	5306	Insert Divider Tab	Two (2) per divider
51	5168	Insert Divider Screw	Drill #8 Countersink

Ship To:
Sales Order #

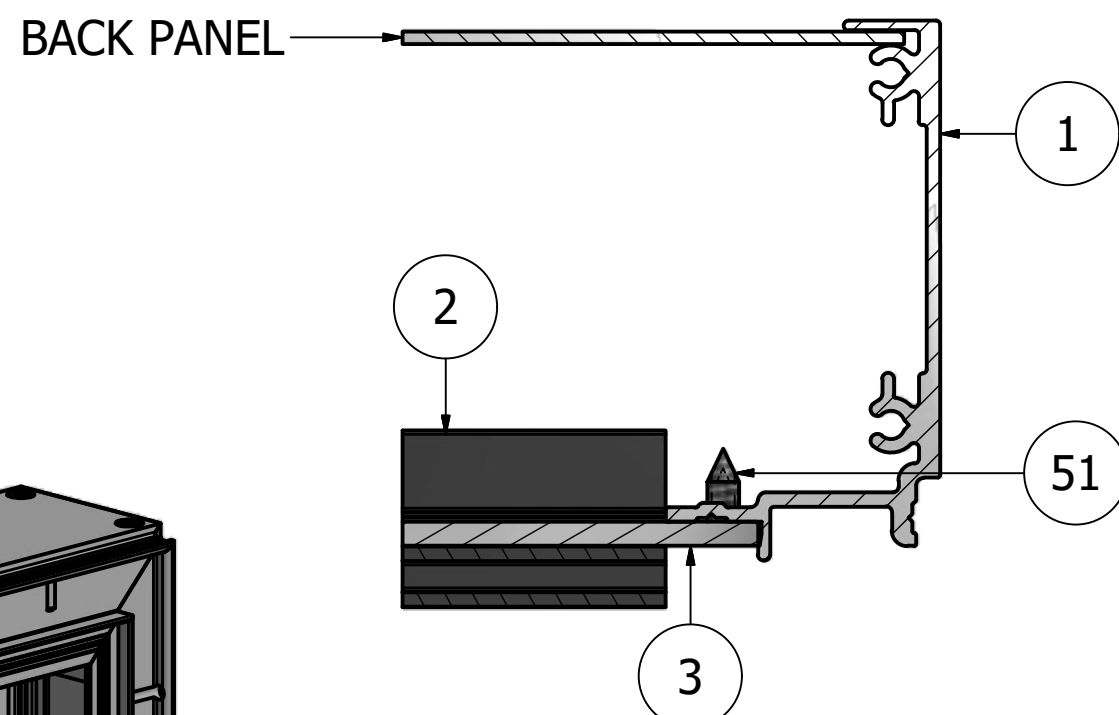
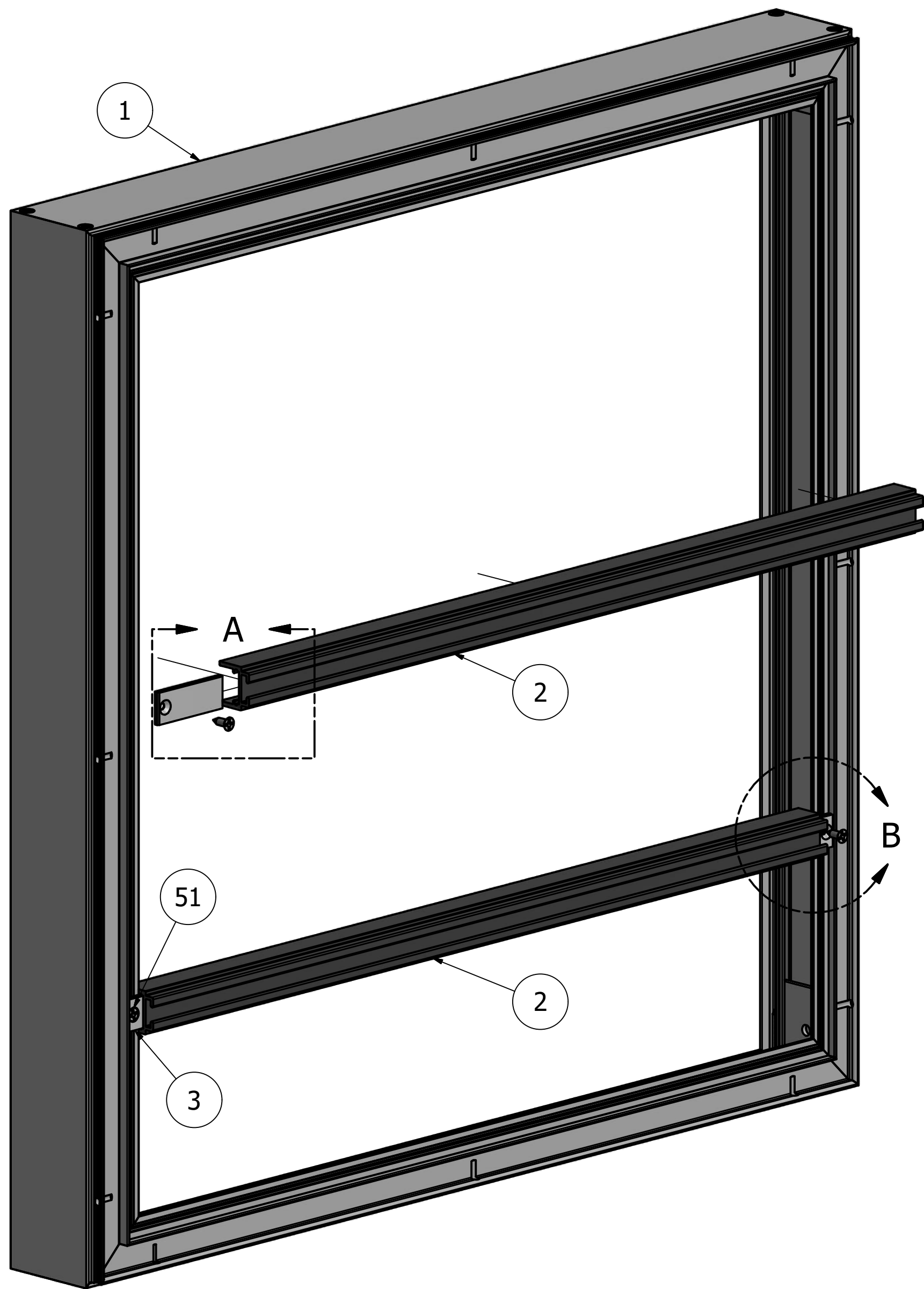

SIDE CROSS-SECTION

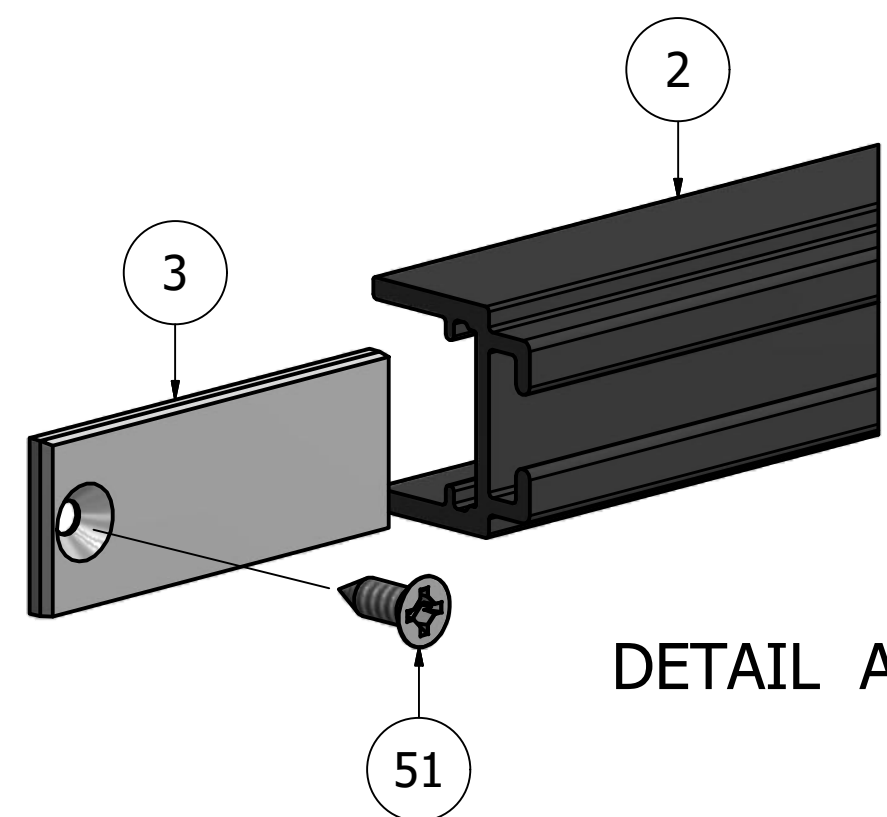

DETAIL A

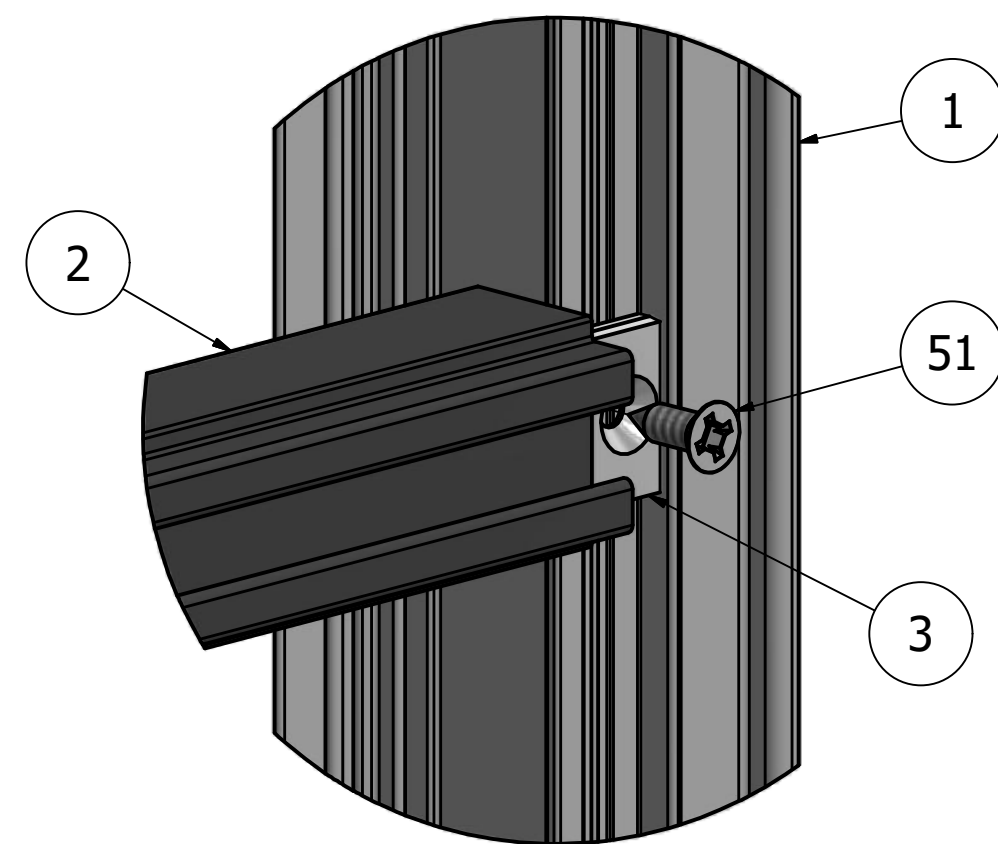

DETAIL B

NOTE: PRE-CUT KITS ARE NOT PRE-DRILLED.
(Holes shown in this drawing are for reference only.
Drilling of pilot holes are to be done by fabricator.)

THIS DRAWING WAS CREATED AT NO CHARGE TO ASSIST YOU IN VISUALIZING OUR PROPOSAL. THE DRAWING HEREIN IS THE PROPERTY OF SIGNCOMP. PERMISSION TO COPY OR REVISE THIS DRAWING OR TO USE THIS DRAWING FOR PRODUCTION IS STRICTLY PROHIBITED AND CAN ONLY BE COPIED, REVISED OR USED FOR PRODUCTION WITH THE EXPRESSED WRITTEN PERMISSION OF SIGNCOMP.

DRAWN	SBreihof	9/25/2012	SignComp
Centroid X:	0.000 in	Centroid Y:	
Principal Moments Ix:	0.000 in ⁴	Principal Moments Iy:	0.000 in ⁴
Section Modulus Ix:	0.000 in ³	Section Modulus Iy:	0.000 in ³
TITLE			Series 3 - Single Face Access Body with Insert Divider - Assembly
DWG NO			
REV			
SHEET 1 OF 1			

PARTS LIST			
ITEM	PART#	DESCRIPTION	NOTES
1	1291	Series 3 Single Face Access Body	Assembly
2	1292	Insert Top & Bottom Cover	
70	5168	Insert Top & Bottom Cover Screw	Drill #8 Countersink

Ship To:
Sales Order #

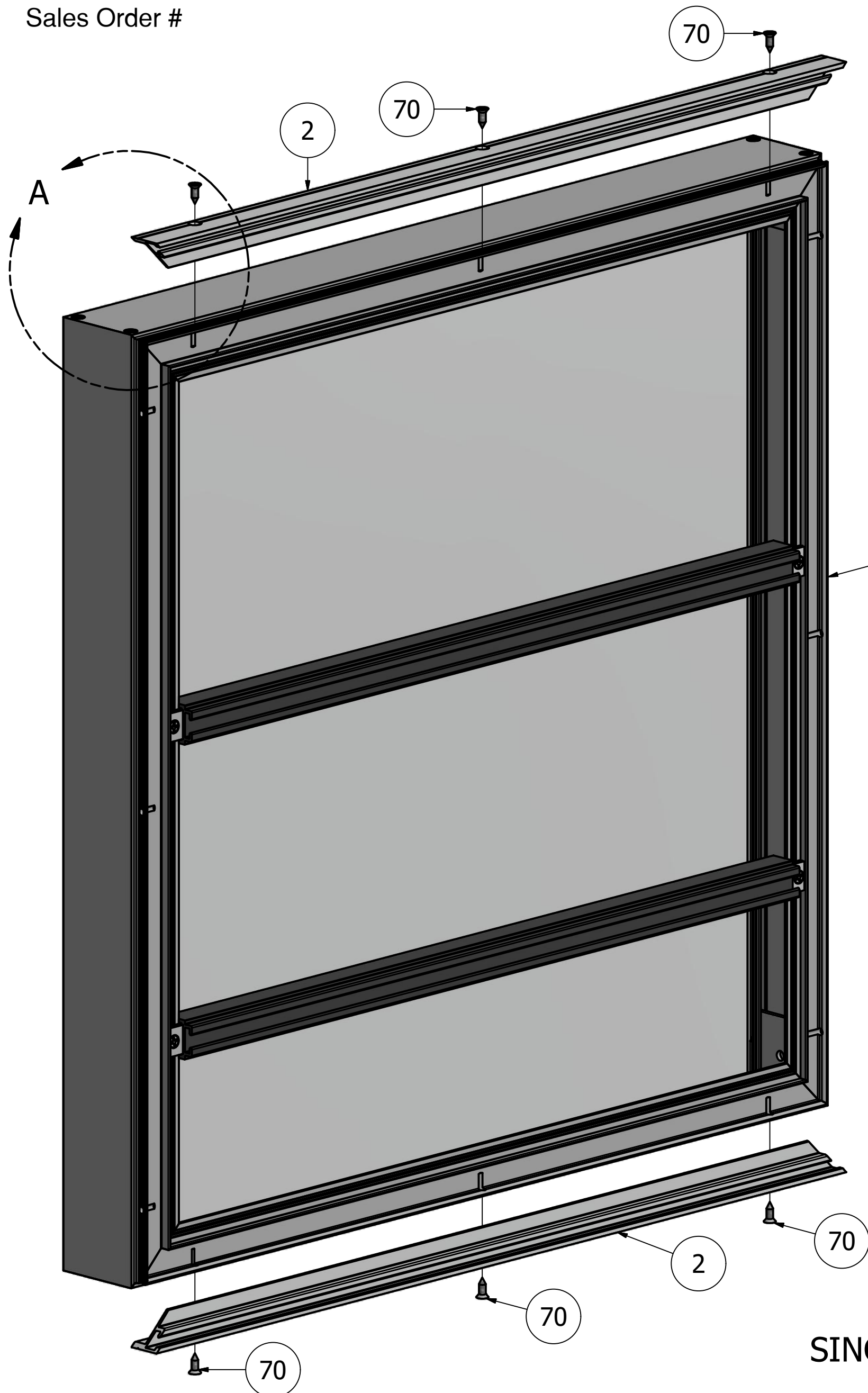

SINGLE SIDED BODY

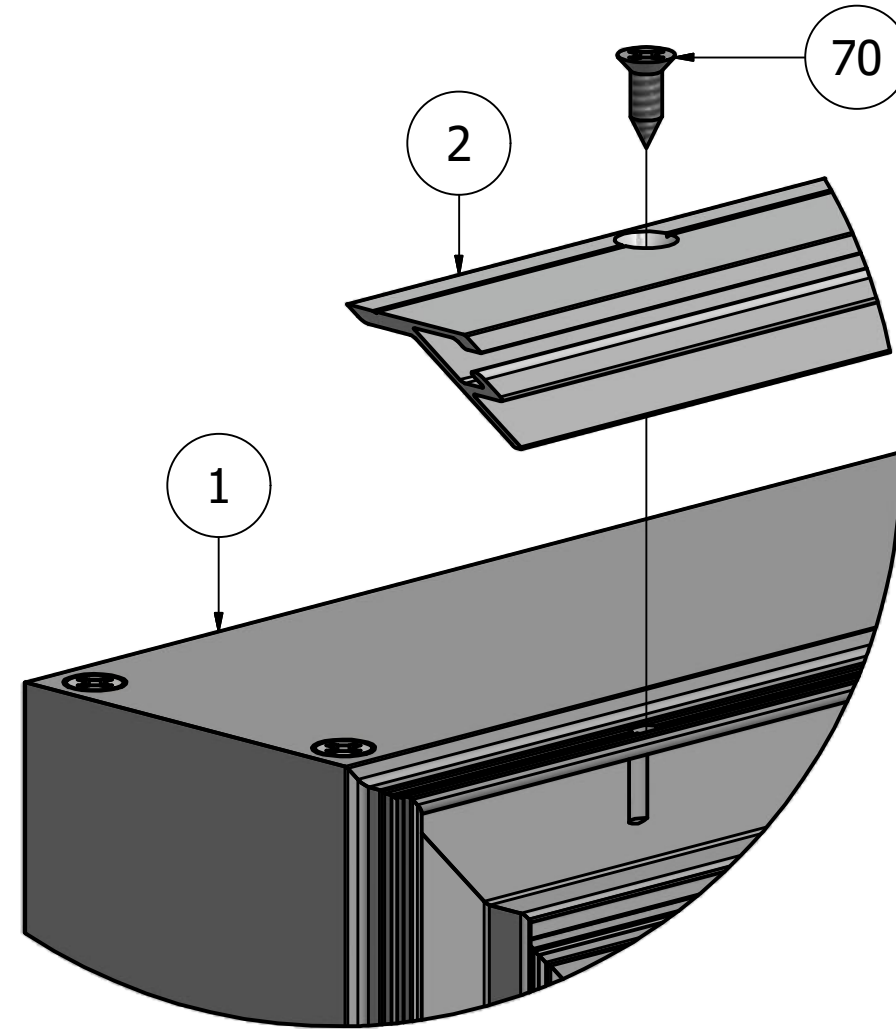

DETAIL A-1
Unassembled

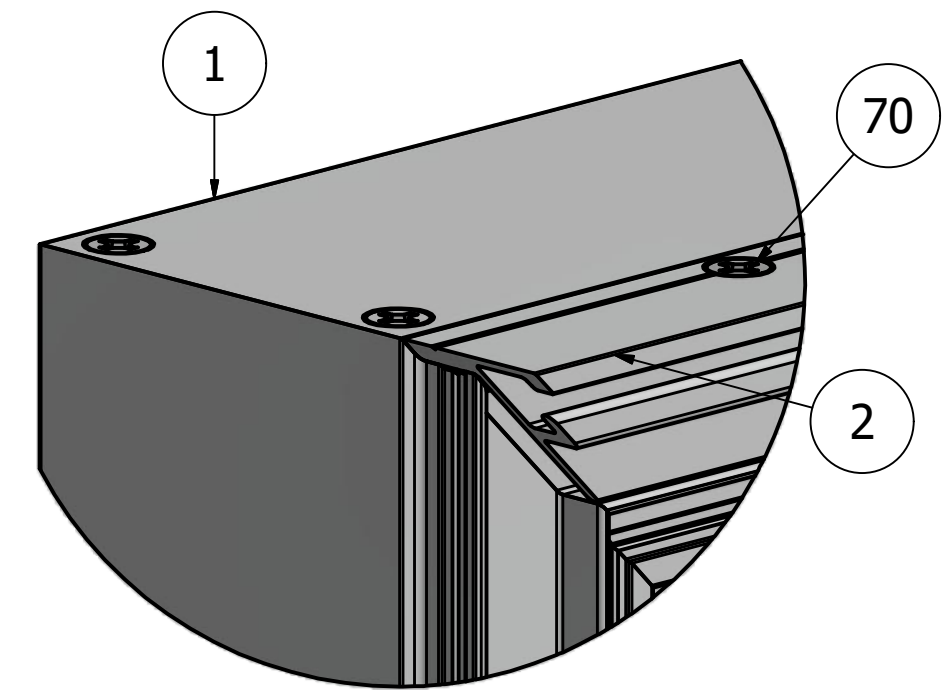

DETAIL A-2
Assembled

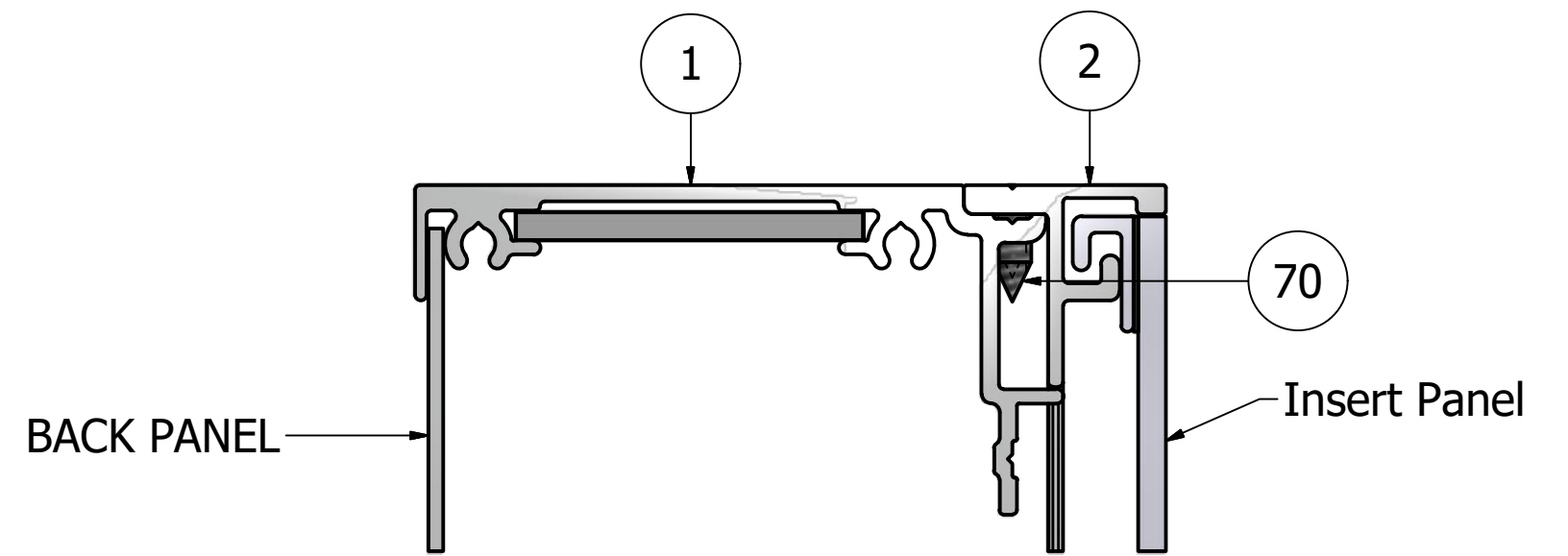

TOP CROSS-SECTION

NOTE: PRE-CUT KITS ARE NOT PRE-DRILLED.

(Holes shown in this drawing are for reference only.
Drilling of pilot holes are to be done by fabricator.)

THIS DRAWING WAS CREATED AT NO CHARGE TO ASSIST YOU IN VISUALIZING OUR PROPOSAL. THE DRAWING HEREIN IS THE PROPERTY OF SIGNCOMP. PERMISSION TO COPY OR REVISE THIS DRAWING OR TO USE THIS DRAWING FOR PRODUCTION IS STRICTLY PROHIBITED AND CAN ONLY BE COPIED, REVISED OR USED FOR PRODUCTION WITH THE EXPRESSED WRITTEN PERMISSION OF SIGNCOMP.

DRAWN	SBreihof	9/25/2012	SignComp
Centroid X:	0.000 in	TITLE	
Centroid Y:	0.000 in	Series 3 - Single Face Access Body w/ Insert Top & Bottom Cover - Assembly	
Principal Moments Ix:	0.000 in ⁴	DWG NO	K1291/1292
Principal Moments Iy:	0.000 in ⁴	REV	
Section Modulus Ix:	0.000 in ³	SHEET 1 OF 1	
Section Modulus Iy:	0.000 in ³		

PARTS LIST			
ITEM	PART#	DESCRIPTION	NOTES
1	K1291	Single Face Access Body	Assembly
2	1292	Insert Cover	Top & Bottom
3	1696/1698	Insert End Cover/Ext. Insert End Cover	Sides
4	1668	Insert Divider	
5	1689	Panel w/ Plastic Insert Adaptors	Panel by Other
6	1679	Panel w/ Aluminum Insert Adaptors	Panel by Other
7	1674/76/78	4", 6", 8" Aluminum insert Panels	
54	5168	Insert End Cover Screw	Drill #8 Countersink

NOTE: PRE-CUT KITS ARE NOT PRE-DRILLED.

(Holes shown in this drawing are for reference only.
Drilling of pilot holes are to be done by fabricator.)

Ship To:
Sales Order #

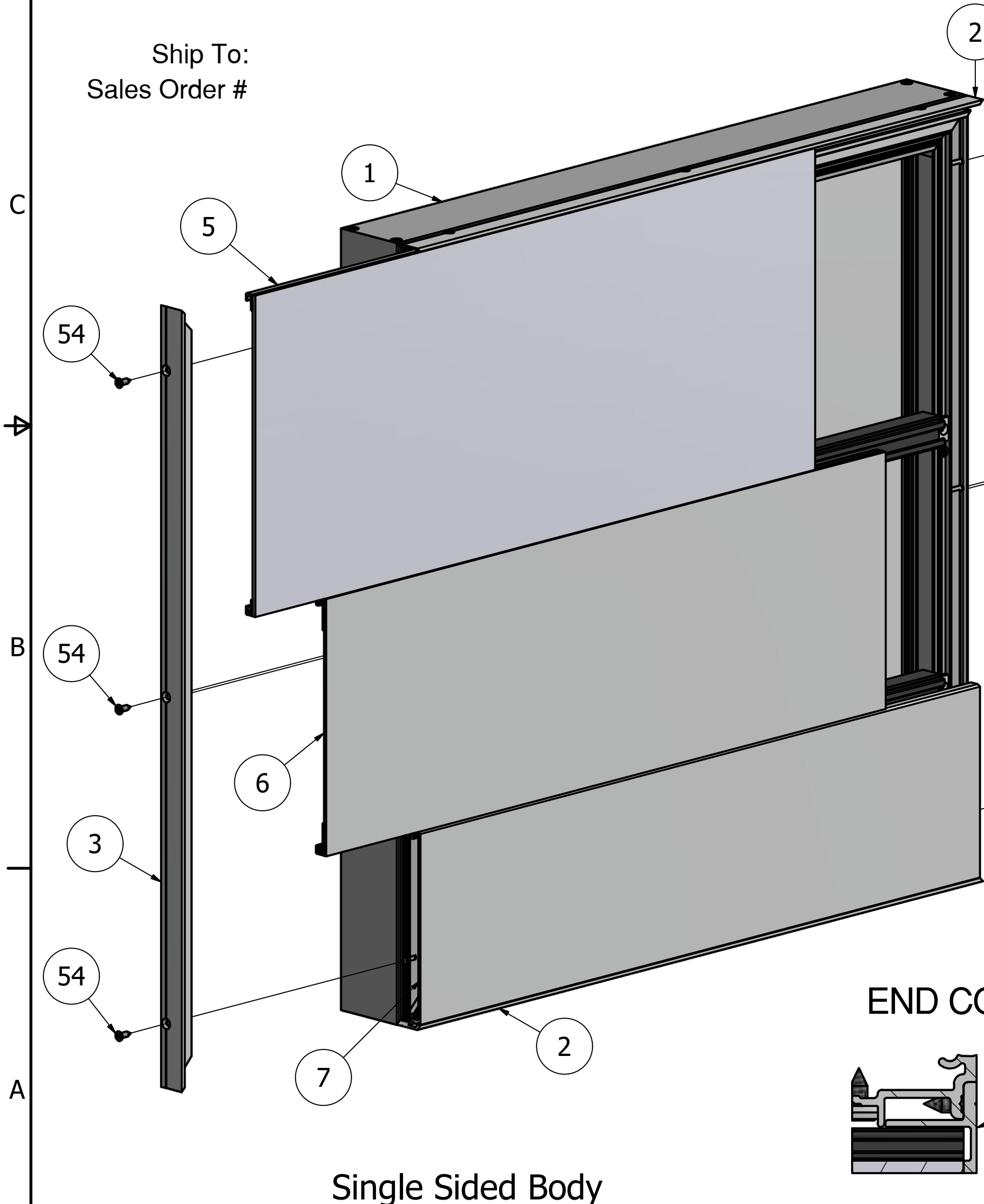

Single Sided Body

END COVER OPTIONS

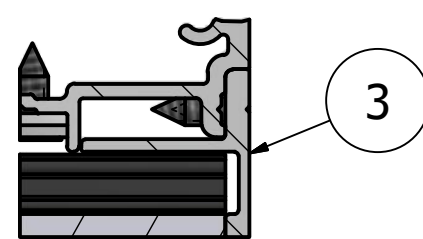

End Cover #1696

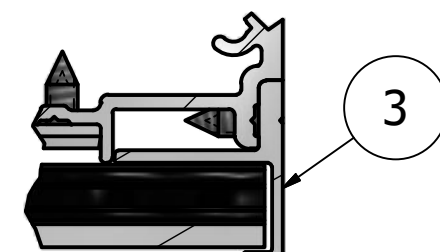

Ext. End Cover #1698

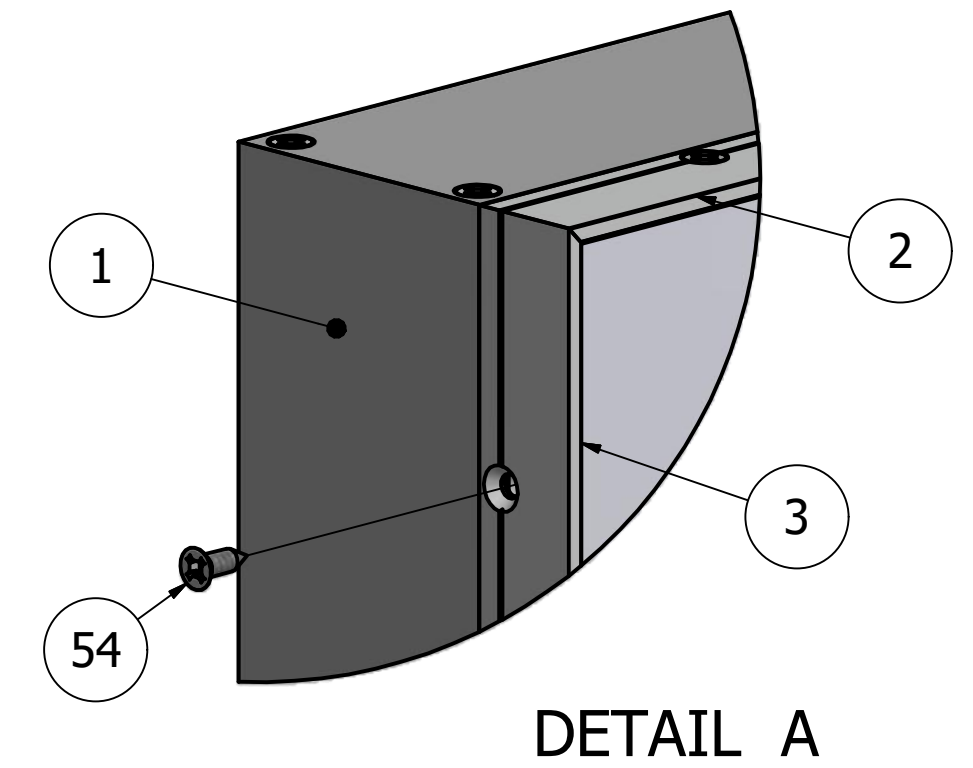
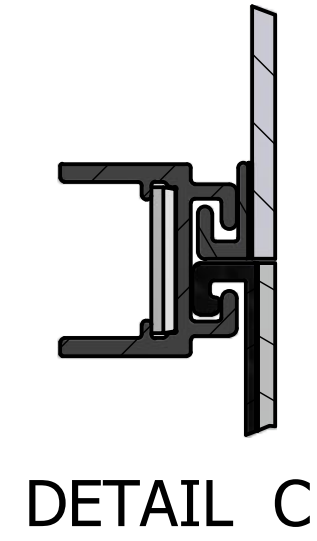
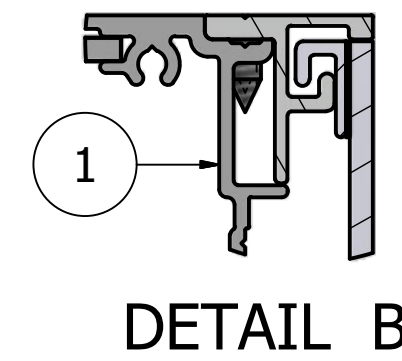
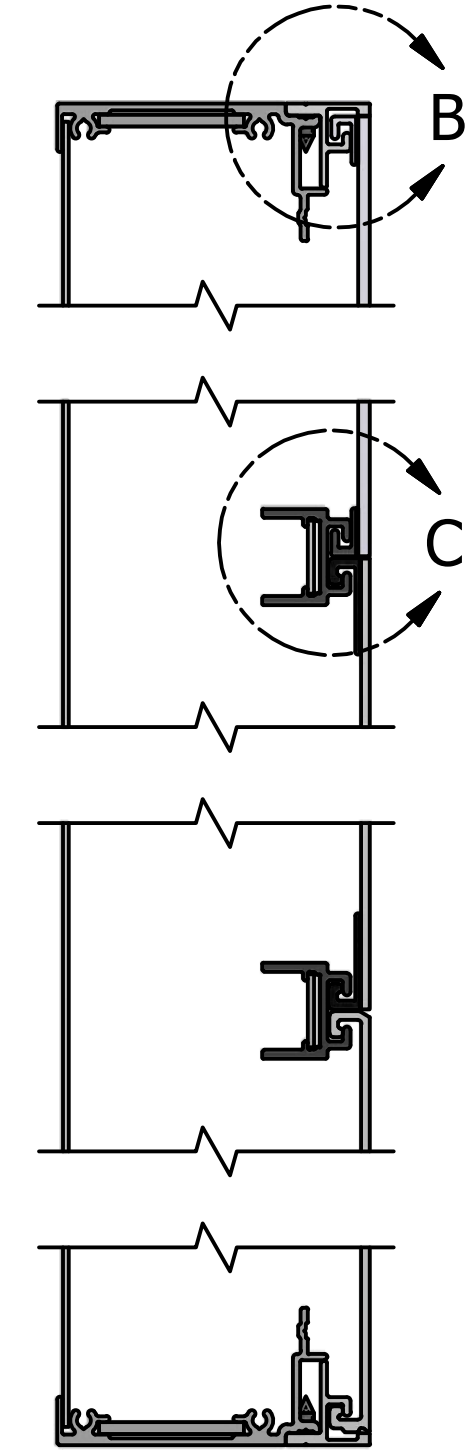
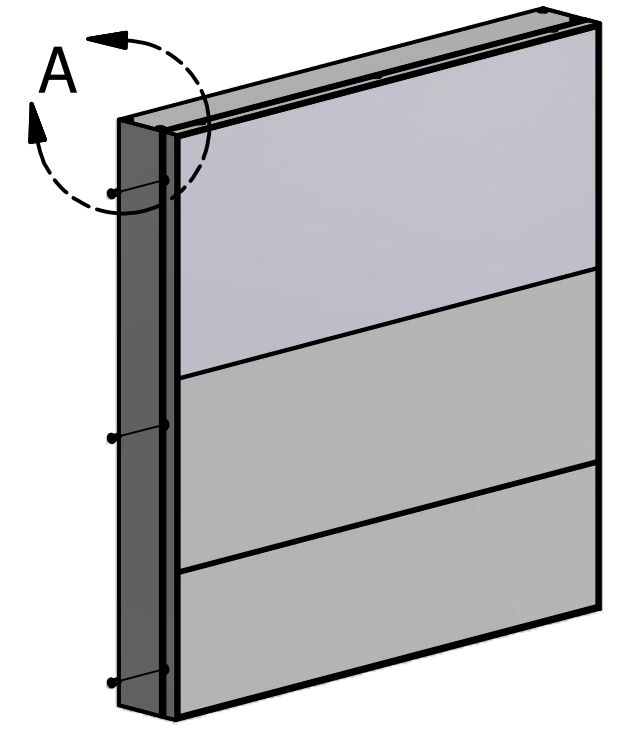
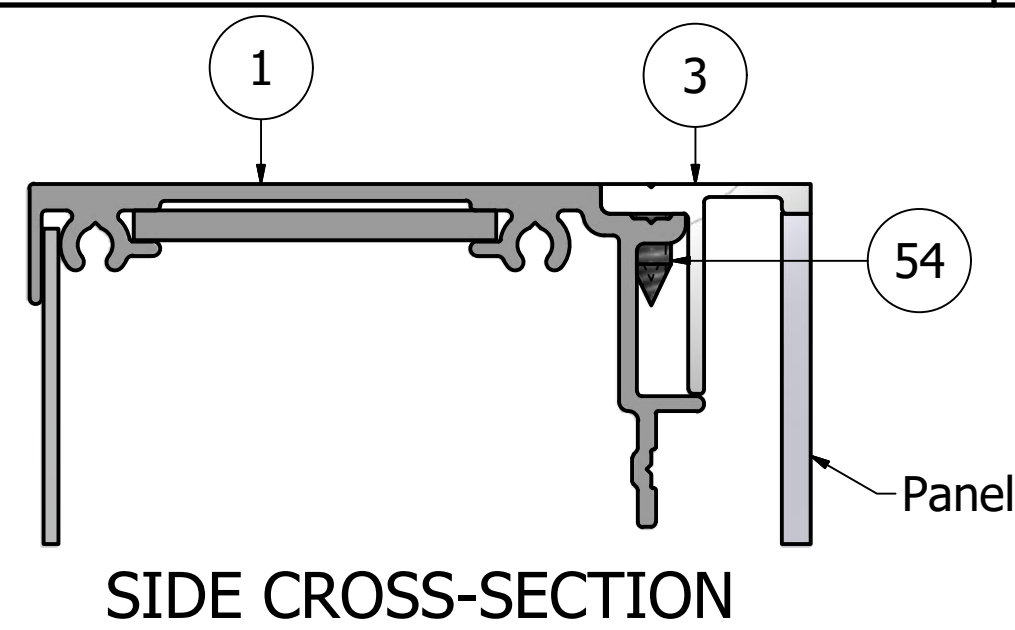

CABINET SECTION-VIEW THROUGH HORIZONTALS

THIS DRAWING WAS CREATED AT NO CHARGE TO ASSIST YOU IN VISUALIZING OUR PROPOSAL. THE DRAWING HEREIN IS THE PROPERTY OF SIGNCOMP. PERMISSION TO COPY OR REVISE THIS DRAWING OR TO USE THIS DRAWING FOR PRODUCTION IS STRICTLY PROHIBITED AND CAN ONLY BE COPIED, REVISED OR USED FOR PRODUCTION WITH THE EXPRESSED WRITTEN PERMISSION OF SIGNCOMP.

DRAWN	SBreihof	9/24/2012
Centroid X:	0.000 in	
Centroid Y:	0.000 in	
Principal Moments Ix:	0.000 in ⁴	
Principal Moments Iy:	0.000 in ⁴	
Section Modulus Ix:	0.000 in ³	
Section Modulus Iy:	0.000 in ³	

SignComp	
TITLE	
Series 3 - Single Face Access Body w/ Insert Covers & Insert End Cover - Assembly	
DWG NO	REV
K1291/92/96	
SHEET 1 OF 1	

Parts List			
ITEM	PART #	DESCRIPTION	NOTES
1	Plastic Stock	.120 Acrylic Sheet	By Fabricator
2	Adhesive	Adhesive Tape (for Plastic) or Liquid Bonding Agent	By Fabricator
3	1689	Plastic Insert Adaptor	Top & Bottom

Ship To:
Order Number:

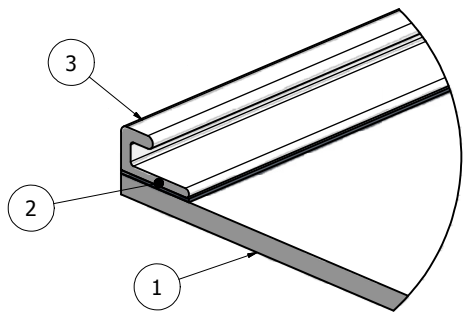
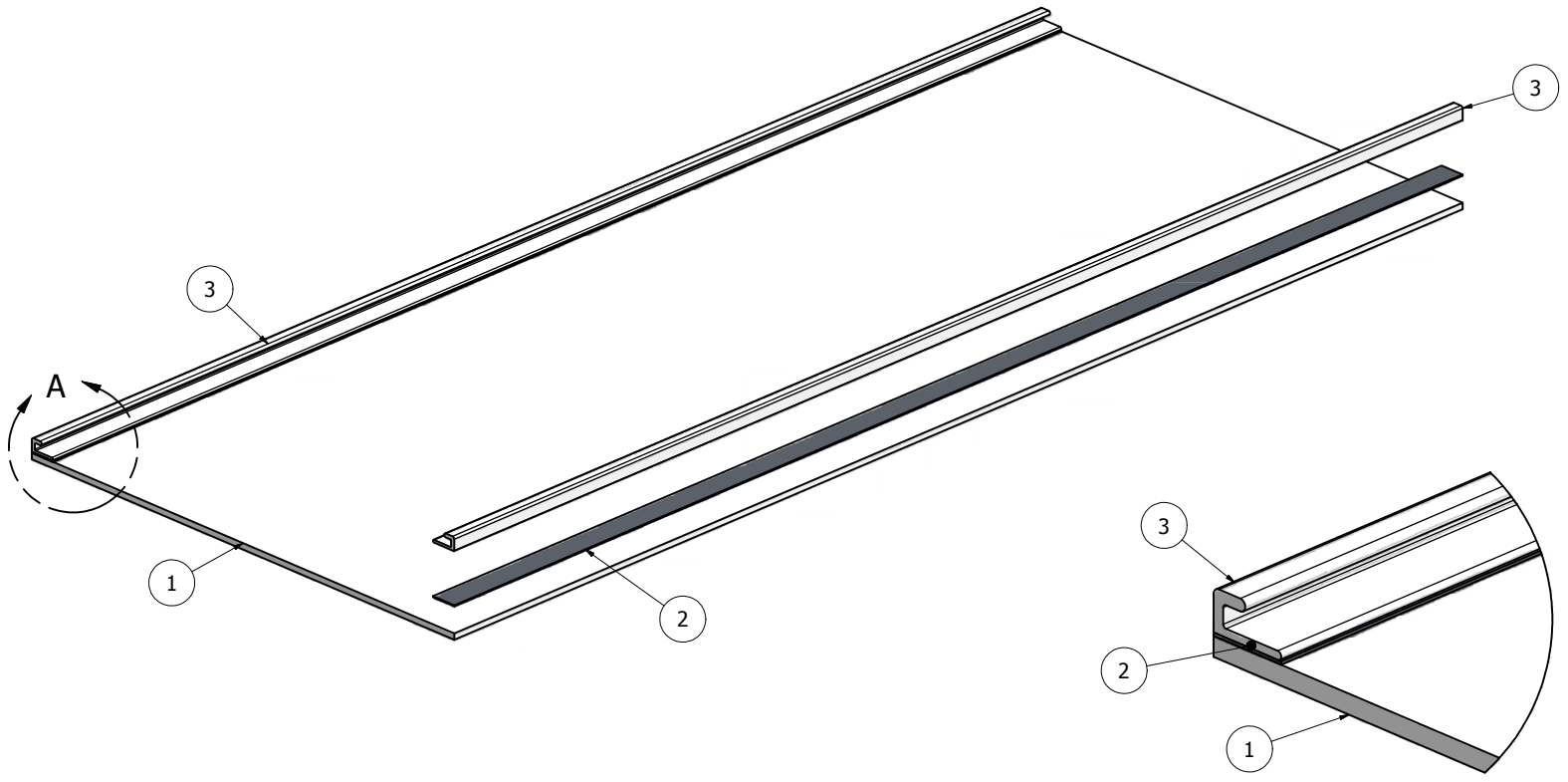

DETAIL A

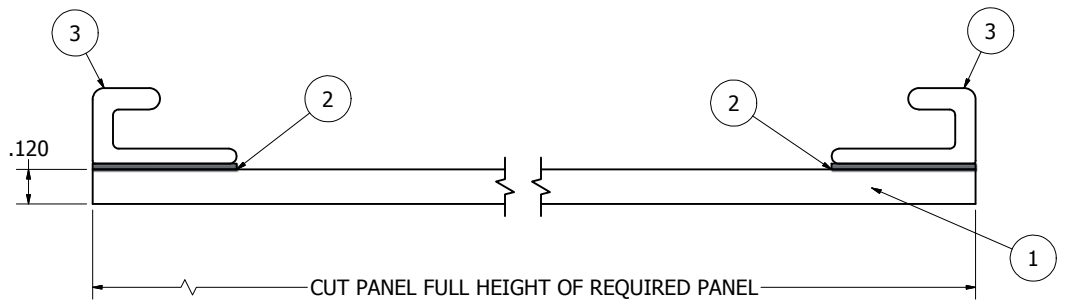

NOTE: PRE-CUT KITS ARE NOT PRE-DRILLED.
(Holes shown in this drawing are for reference only.
Drilling of pilot holes are to be done by fabricator.)

THIS DRAWING WAS CREATED AT NO CHARGE TO ASSIST YOU IN VISUALIZING OUR PROPOSAL. THE DRAWING HEREIN IS THE PROPERTY OF SIGNCOMP. PERMISSION TO COPY OR REVISE THIS DRAWING OR TO USE THIS DRAWING FOR PRODUCTION IS STRICTLY PROHIBITED AND CAN ONLY BE COPIED, REVISED OR USED FOR PRODUCTION WITH THE EXPRESSED WRITTEN PERMISSION OF SIGNCOMP.

DRAWN	Steve	12/15/2008	SignComp		
CHECKED					
QA			TITLE		
MFG			Plastic Insert Panel Adaptors - Assembly		
APPROVED			SIZE	DWG NO	REV
			C	1689	
			SCALE	SHEET 1 OF 1	

Parts List			
ITEM	PART #	DESCRIPTION	NOTES
1	Aluminum Stock	.090 Flat Aluminum Sheet	By Fabricator
2	Tape/Adhesive	Bonding Tape or Bonding Adhesive	For Aluminum Bonding - By Fabricator
3	1679	Aluminum Insert Adaptor	Top and Bottom

Ship To:
Order Number:

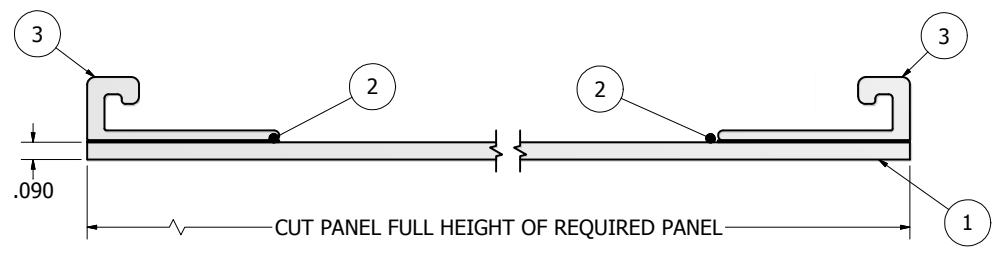
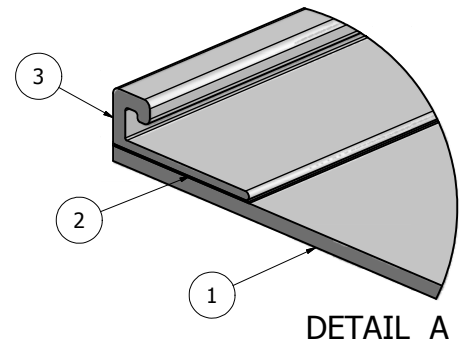
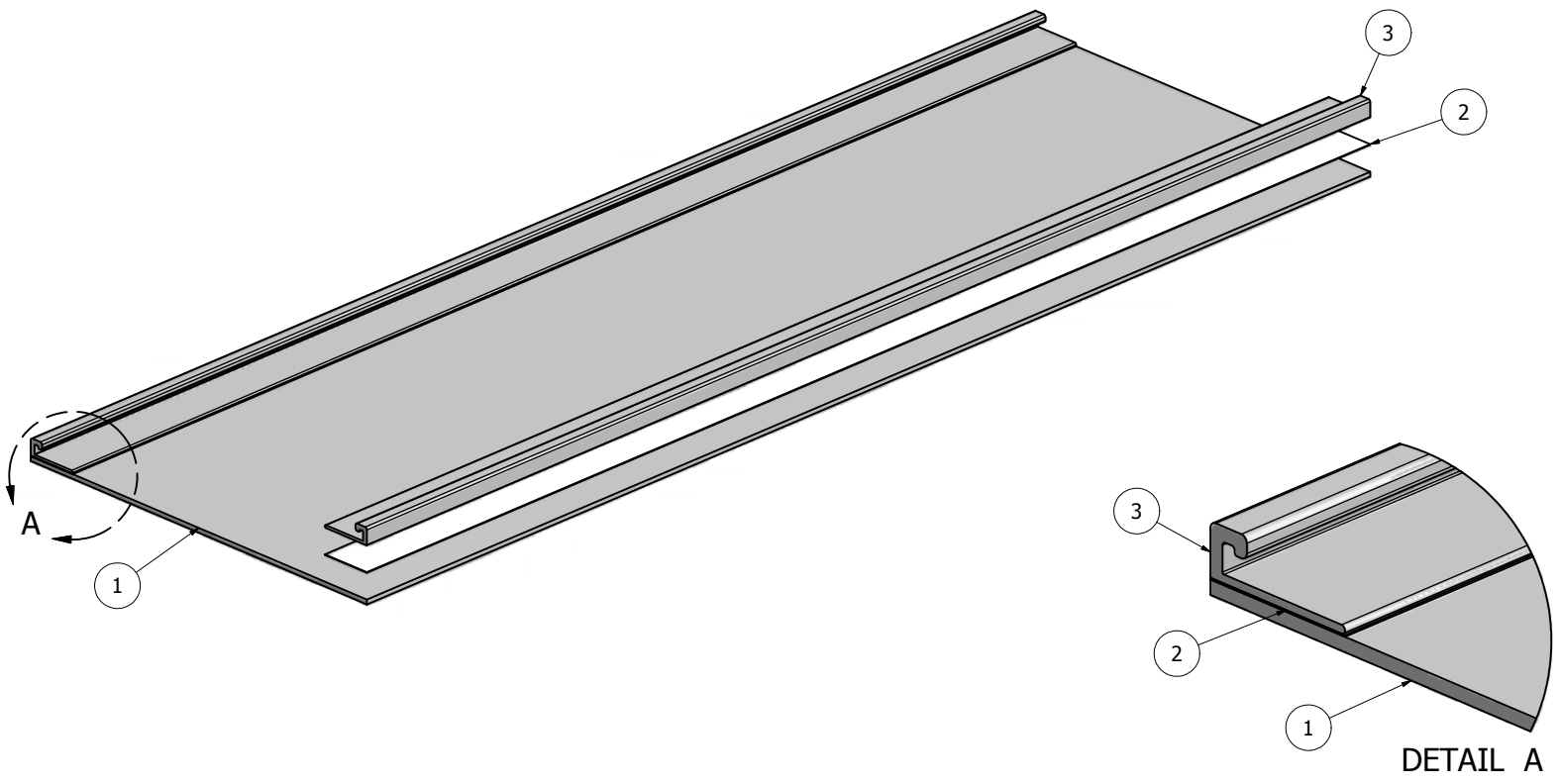

NOTE: PRE-CUT KITS ARE NOT PRE-DRILLED.
(Holes shown in this drawing are for reference only.
Drilling of pilot holes are to be done by fabricator.)

THIS DRAWING WAS CREATED AT NO CHARGE TO ASSIST YOU IN VISUALIZING OUR PROPOSAL. THE DRAWING HEREIN IS THE PROPERTY OF SIGNCOMP. PERMISSION TO COPY OR REVISE THIS DRAWING OR TO USE THIS DRAWING FOR PRODUCTION IS STRICTLY PROHIBITED AND CAN ONLY BE COPIED, REVISED OR USED FOR PRODUCTION WITH THE EXPRESSED WRITTEN PERMISSION OF SIGNCOMP.			
DRAWN	12/15/2008	SignComp	
Steve			
CHECKED			
QA			
MFG		Aluminum Insert Adaptor - Assembly	
APPROVED		SIZE	DWG NO
		C	1679
		SCALE	SHEET 1 OF 1