

PARTS LIST			
ITEM	PART#	DESCRIPTION	NOTES
1	K2025	Single Face Body	Assembly
2	K2086/95	Tension Frame II and Bleed Cover	Assembly
10	5170	Hinge Screw	Drill a 3/8" pilot hole
11	5180	Closure Screw	Drill 5/16" pilot hole

Ship To:
Sales Order#

***NOTE:** Drill a 3/8" oversized hole for the head of the hinge screw to slip through.

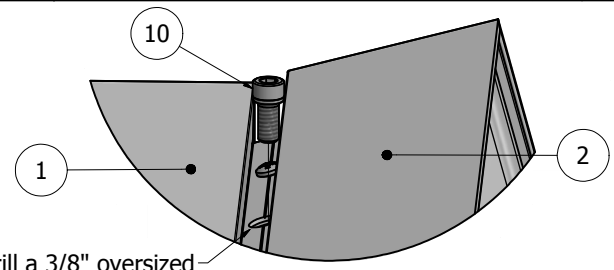
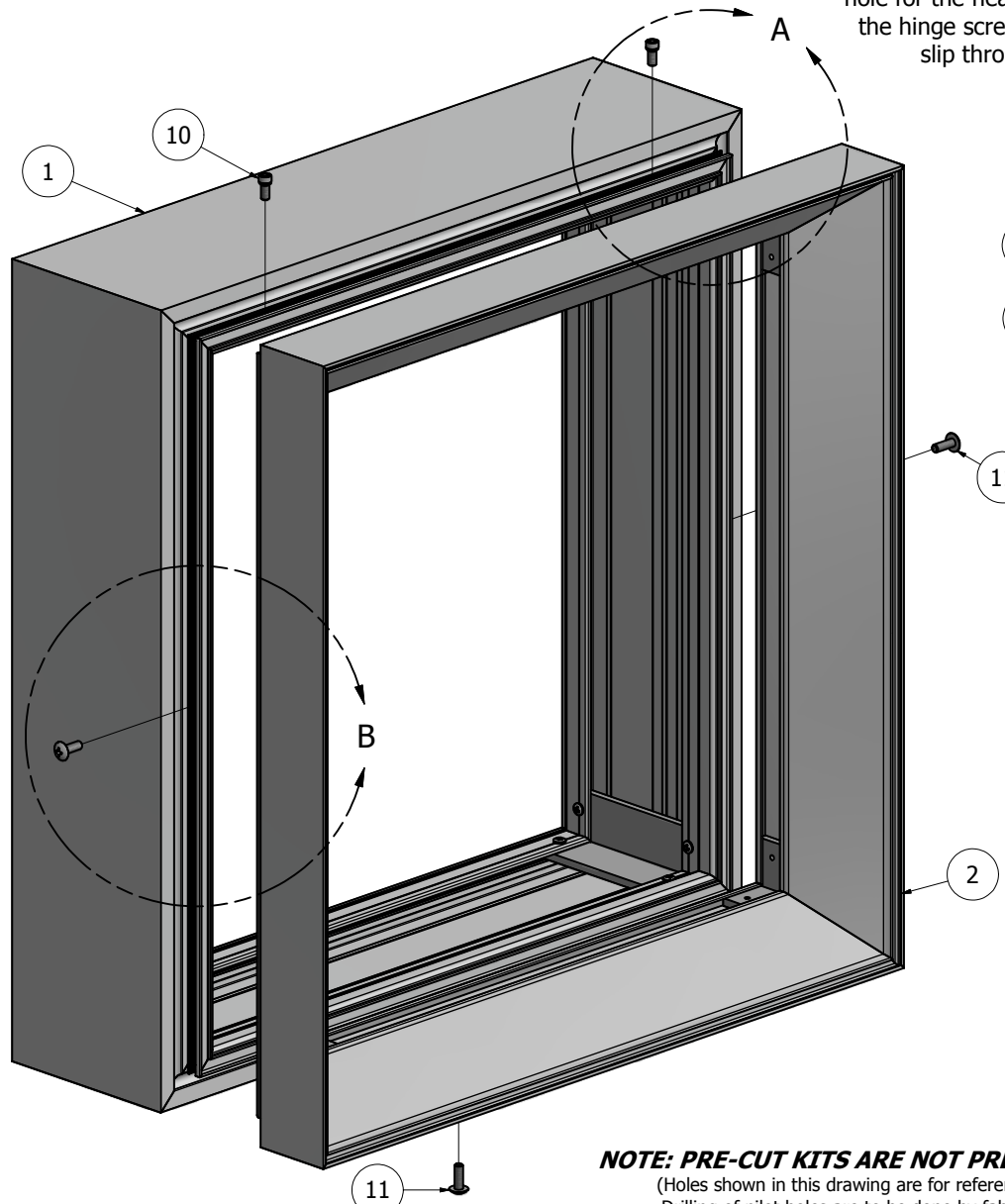

DETAIL A
FRAME HINGED

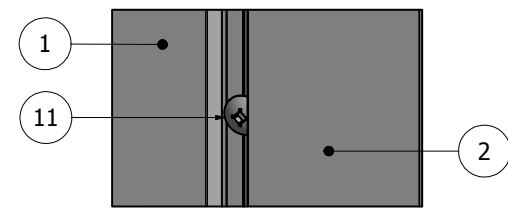
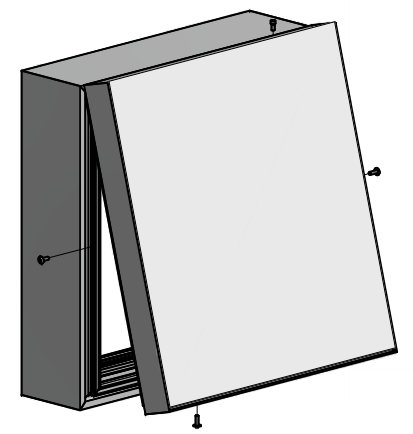

DETAIL B
FRAME CLOSED

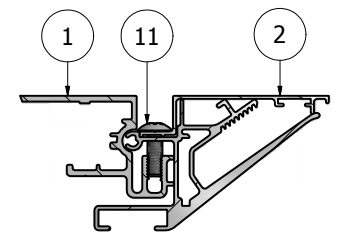

SIDE CROSS-SECTION FRAME CLOSED

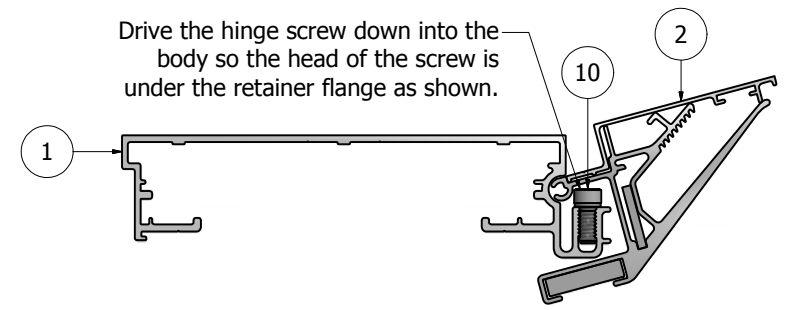

TOP CROSS-SECTION VIEW

NOTE: PRE-CUT KITS ARE NOT PRE-DRILLED.
(Holes shown in this drawing are for reference only. Drilling of pilot holes are to be done by fabricator.)

THIS DRAWING WAS CREATED AT NO CHARGE TO ASSIST YOU IN VISUALIZING OUR PROPOSAL. THE DRAWING HEREIN IS THE PROPERTY OF SIGNCOMP. PERMISSION TO COPY OR REVISE THIS DRAWING OR TO USE THIS DRAWING FOR PRODUCTION IS STRICTLY PROHIBITED AND CAN ONLY BE COPIED, REVISED OR USED FOR PRODUCTION WITH THE EXPRESSED WRITTEN PERMISSION OF SIGNCOMP.			
DRAWING BY:	SBreihof	4/23/2014	SignComp
Centroid X:	0.000 in		
Centroid Y:	0.000 in		TITLE
Principal Moments Ix:	0.000 in ⁴		Single Face Body w/ Tension Frame II and Bleed Cover - Assembly
Principal Moments Iy:	0.000 in ⁴		PART NO
Section Modulus Ix:	0.000 in ³		KSF-86-95
Section Modulus Iy:	0.000 in ³		REV
			SHEET 1 OF 1

Parts List			
ITEM	PART #	DESCRIPTION	NOTES
1	2025	Single Face Body	Top & Bottom
2	2025	Single Face Body	Sides
3	5322	Single Face Body Corner Angle	
13	5218	Corner Angle Screw	Drill 5/32" Pilot Hole

Ship To:
Sales Order#

D

C

B

A

A

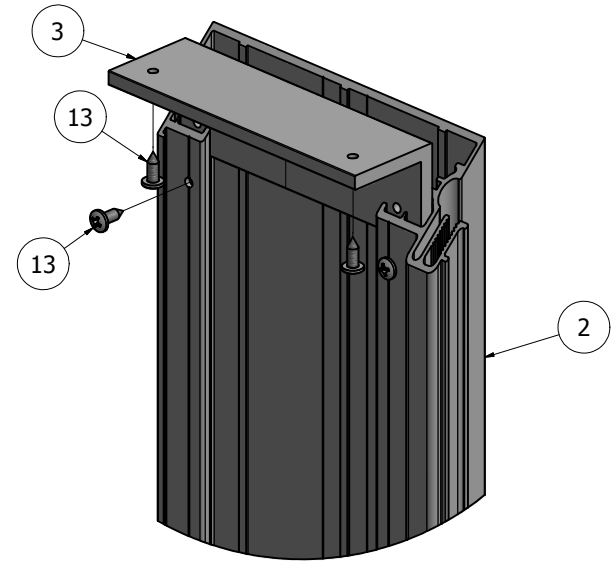
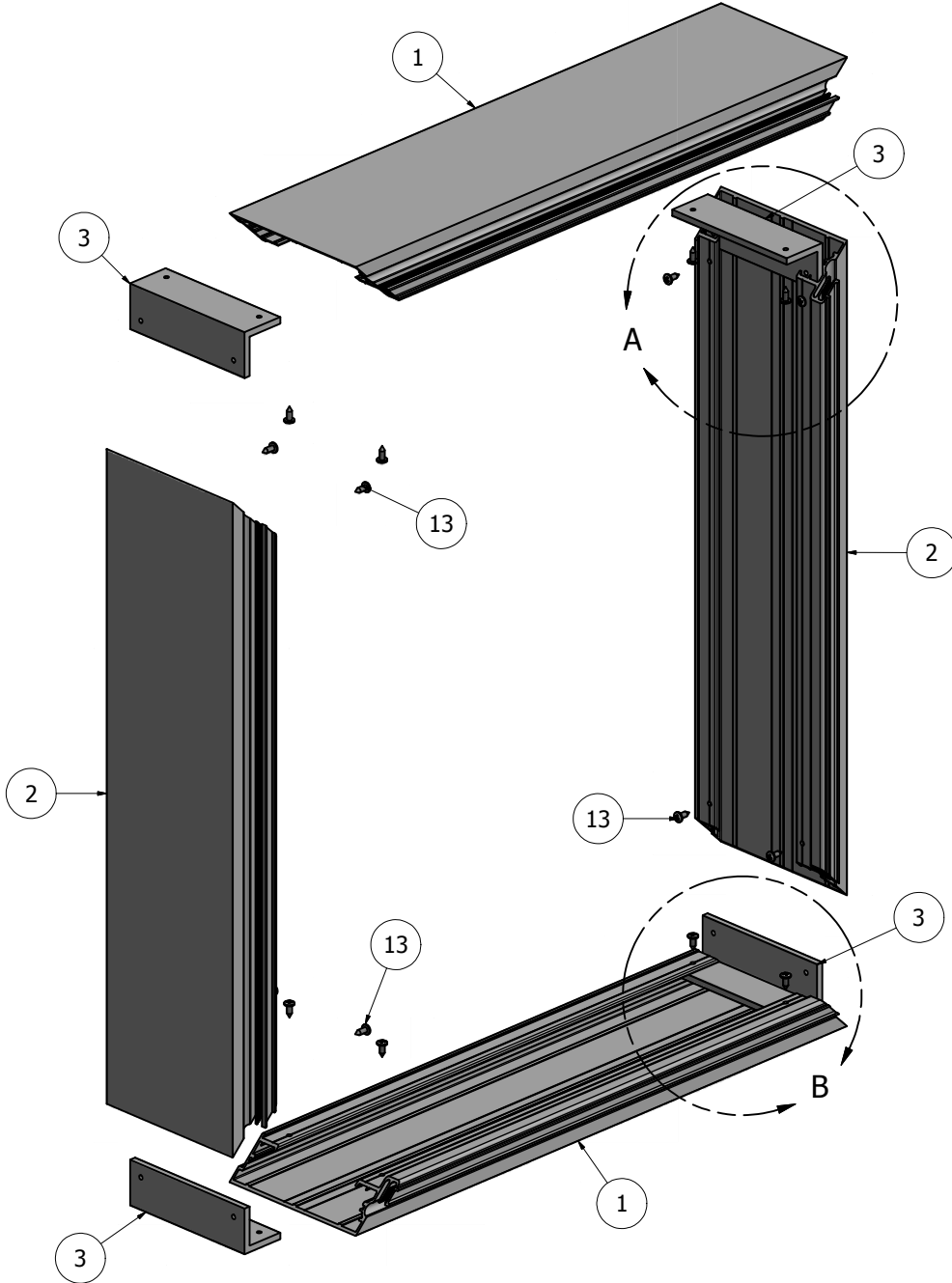

DETAIL A

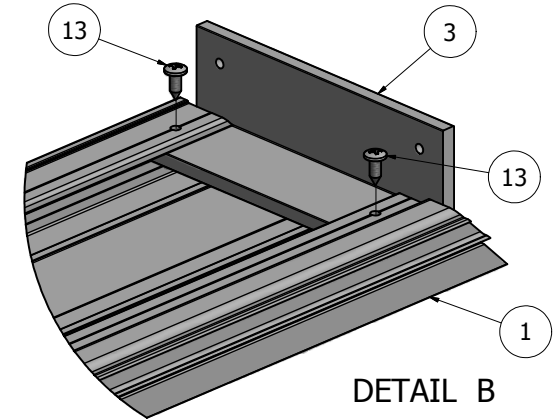

DETAIL B

NOTE: PRE-CUT KITS ARE NOT PRE-DRILLED.
(Holes shown in this drawing are for reference only.
Drilling of pilot holes are to be done by fabricator.)

THIS DRAWING WAS CREATED AT NO CHARGE TO ASSIST YOU IN VISUALIZING OUR PROPOSAL. THE DRAWING HEREIN IS THE PROPERTY OF SIGNCOMP. PERMISSION TO COPY OR REVISE THIS DRAWING OR TO USE THIS DRAWING FOR PRODUCTION IS STRICTLY PROHIBITED AND CAN ONLY BE COPIED, REVISED OR USED FOR PRODUCTION WITH THE EXPRESSED WRITTEN PERMISSION OF SIGNCOMP.

DRAWN	Sarah	3/2/2012	SignComp	
Centroid X:	0.000 in			
Centroid Y:	0.000 in		TITLE	
Principal Moments Ix:	0.000 in ⁴		Single Face Body - Assembly	
Principal Moments Iy:	0.000 in ⁴		DWG NO	REV
Section Modulus Ix:	0.000 in ³		K2025	
Section Modulus Iy:	0.000 in ³		SHEET 1 OF 1	

D

C

B

A

A

PARTS LIST			
ITEM	PART#	DESCRIPTION	NOTES
1	2086	Tension Frame II	Top & Bottom
2	2086	Tension Frame II	Sides
3	5210	Corner Key	
4	5305	Frame Corner Angle	
85	5218	Corner Angle Screw	Pre-drill 5/32" hole

THE CORNER KEYS FLOAT IN THE EXTRUSION HELPING TO ALIGN THE MITERS AND ADD STRENGTH.

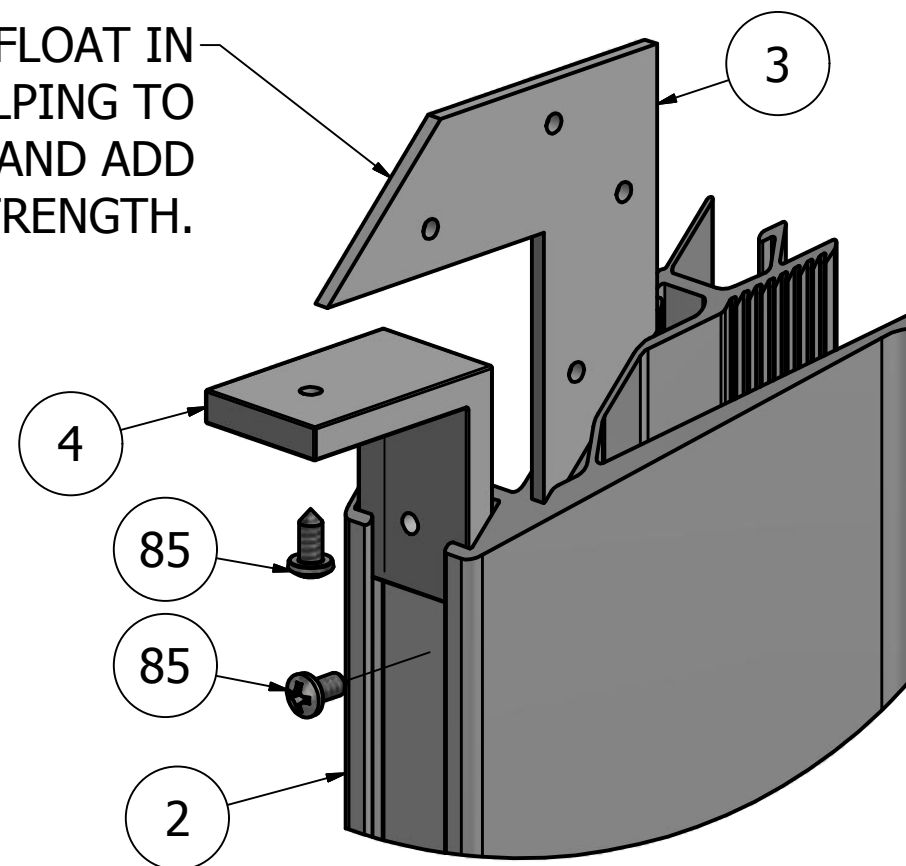

DETAIL A

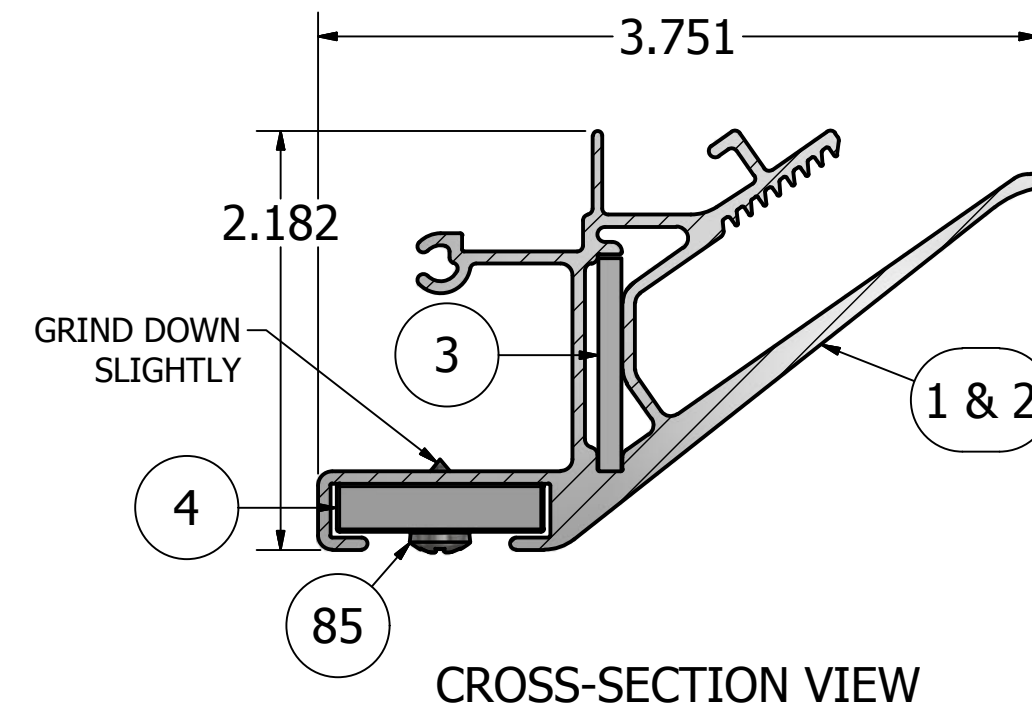

CROSS-SECTION VIEW

SHIP TO:
SALES ORDER #

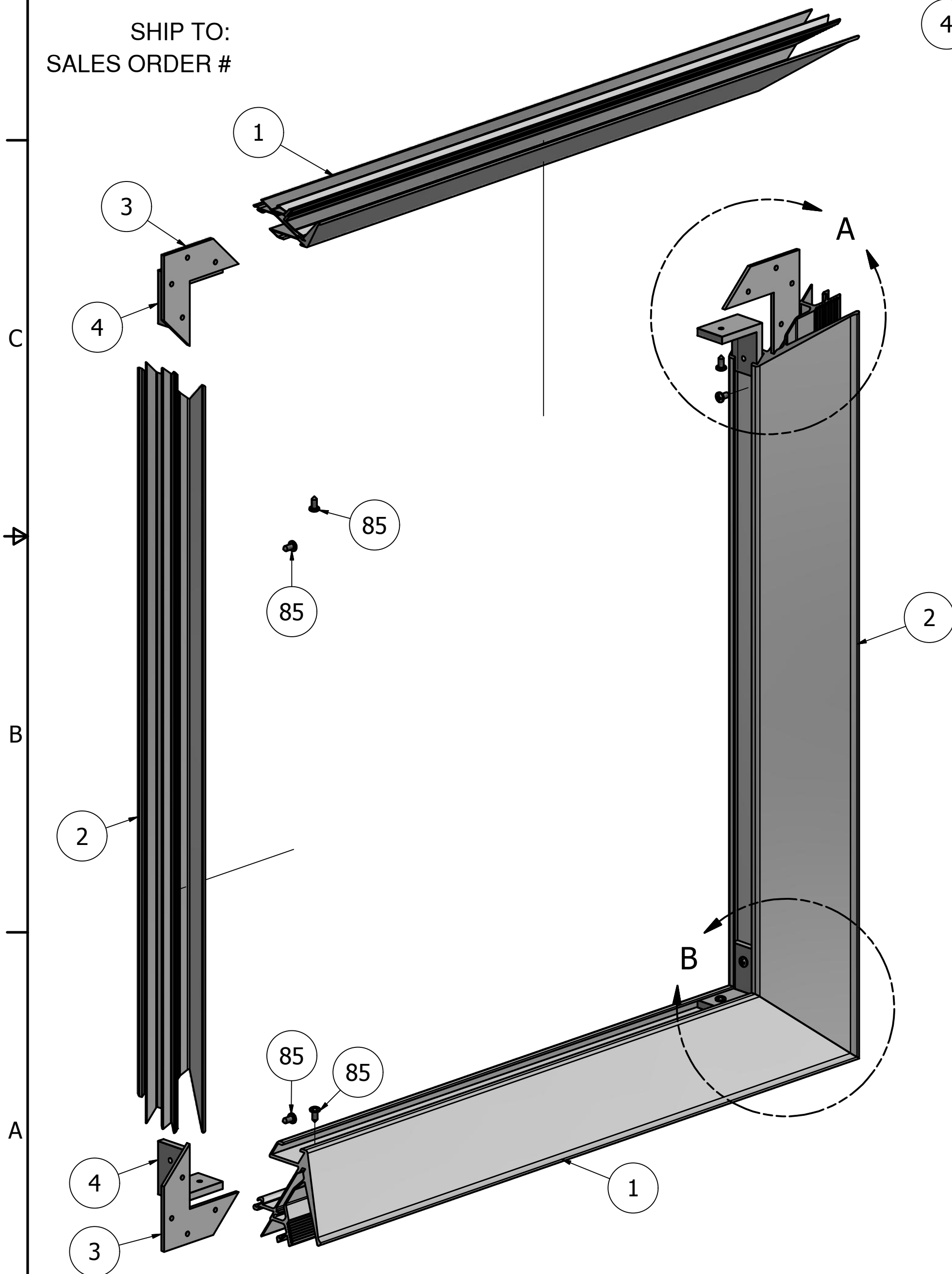

NOTE: THIS FRAME MAY BE BONDED, WELDED OR ASSEMBLED WITH FASTENERS.

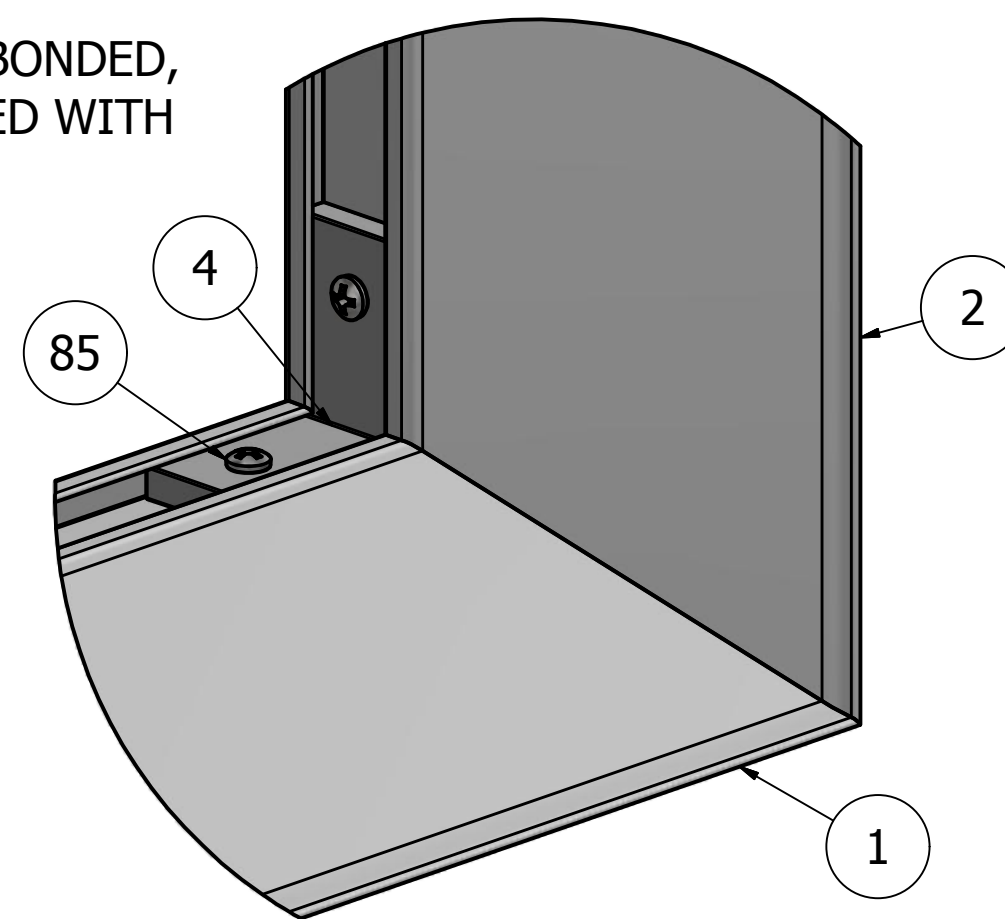

DETAIL B

NOTE: PRE-CUT KITS ARE NOT PRE-DRILLED.
(Holes shown in this drawing are for reference only.
Drilling of pilot holes are to be done by fabricator.)

THIS DRAWING WAS CREATED AT NO CHARGE TO ASSIST YOU IN VISUALIZING OUR PROPOSAL. THE DRAWING HEREIN IS THE PROPERTY OF SIGNCOMP. PERMISSION TO COPY OR REVISE THIS DRAWING OR TO USE THIS DRAWING FOR PRODUCTION IS STRICTLY PROHIBITED AND CAN ONLY BE COPIED, REVISED OR USED FOR PRODUCTION WITH THE EXPRESSED WRITTEN PERMISSION OF SIGNCOMP.

DRAWING BY:	SBreihof	4/24/2014	SignComp
Centroid X:	0.000 in	Centroid Y:	
Principal Moments Ix:	0.000 in ⁴	Principal Moments Iy:	0.000 in ⁴
Section Modulus Ix:	0.000 in ³	Section Modulus Iy:	0.000 in ³
TITLE			Tension Frame II - Assembly
PART NO			K2086
REV			
SHEET			1 OF 1

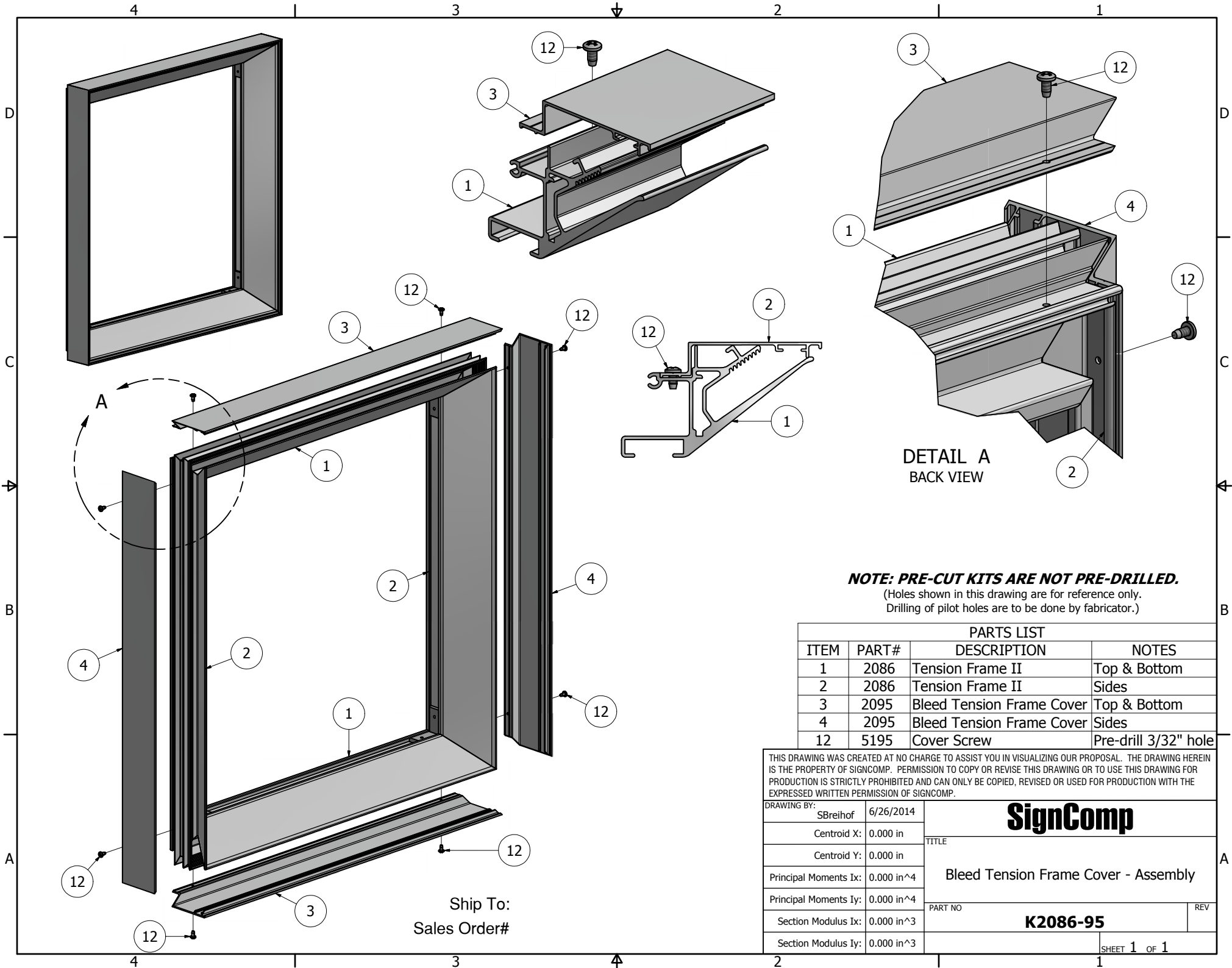

NOTE: PRE-CUT KITS ARE NOT PRE-DRILLED.
 (Holes shown in this drawing are for reference only.
 Drilling of pilot holes are to be done by fabricator.)

PARTS LIST			
ITEM	PART #	DESCRIPTION	NOTES
1	2086	Tension Frame II	Top & Bottom
2	2086	Tension Frame II	Sides
3	2095	Bleed Tension Frame Cover	Top & Bottom
4	2095	Bleed Tension Frame Cover	Sides
12	5195	Cover Screw	Pre-drill 3/32" hole

THIS DRAWING WAS CREATED AT NO CHARGE TO ASSIST YOU IN VISUALIZING OUR PROPOSAL. THE DRAWING HEREIN IS THE PROPERTY OF SIGNCOMP. PERMISSION TO COPY OR REVISE THIS DRAWING OR TO USE THIS DRAWING FOR PRODUCTION IS STRICTLY PROHIBITED AND CAN ONLY BE COPIED, REVISED OR USED FOR PRODUCTION WITH THE EXPRESSED WRITTEN PERMISSION OF SIGNCOMP.

DRAWING BY:	SBreihof	6/26/2014
Centroid X:	0.000 in	
Centroid Y:	0.000 in	
Principal Moments Ix:	0.000 in ⁴	
Principal Moments Iy:	0.000 in ⁴	
Section Modulus Ix:	0.000 in ³	
Section Modulus Iy:	0.000 in ³	

SignComp

TITLE
Bleed Tension Frame Cover - Assembly

PART NO
K2086-95

REV

Ship To:
 Sales Order#

PARTS LIST		
ITEM	PART #	DESCRIPTION
1	2025	Single Face Body
2	5322	Single Face Body Corner Angle
3		.060 Alum. Back
4		Alum. Back Support
5		Alum. Gusset
6	5112	Raceway Cover - Blank
7		Lamp & Socket
8	2086	Tension Frame II
9	5210	Corner Key
10	5305	Frame Corner Angle
11	2095	Bleed Tension Frame Cover
12	5350	Frame Brace
13	2175	Frame Support Tube

NOTE: PRE-CUT KITS ARE NOT PRE-DRILLED.
 (Holes shown in this drawing are for reference only.
 Drilling of pilot holes are to be done by fabricator.)

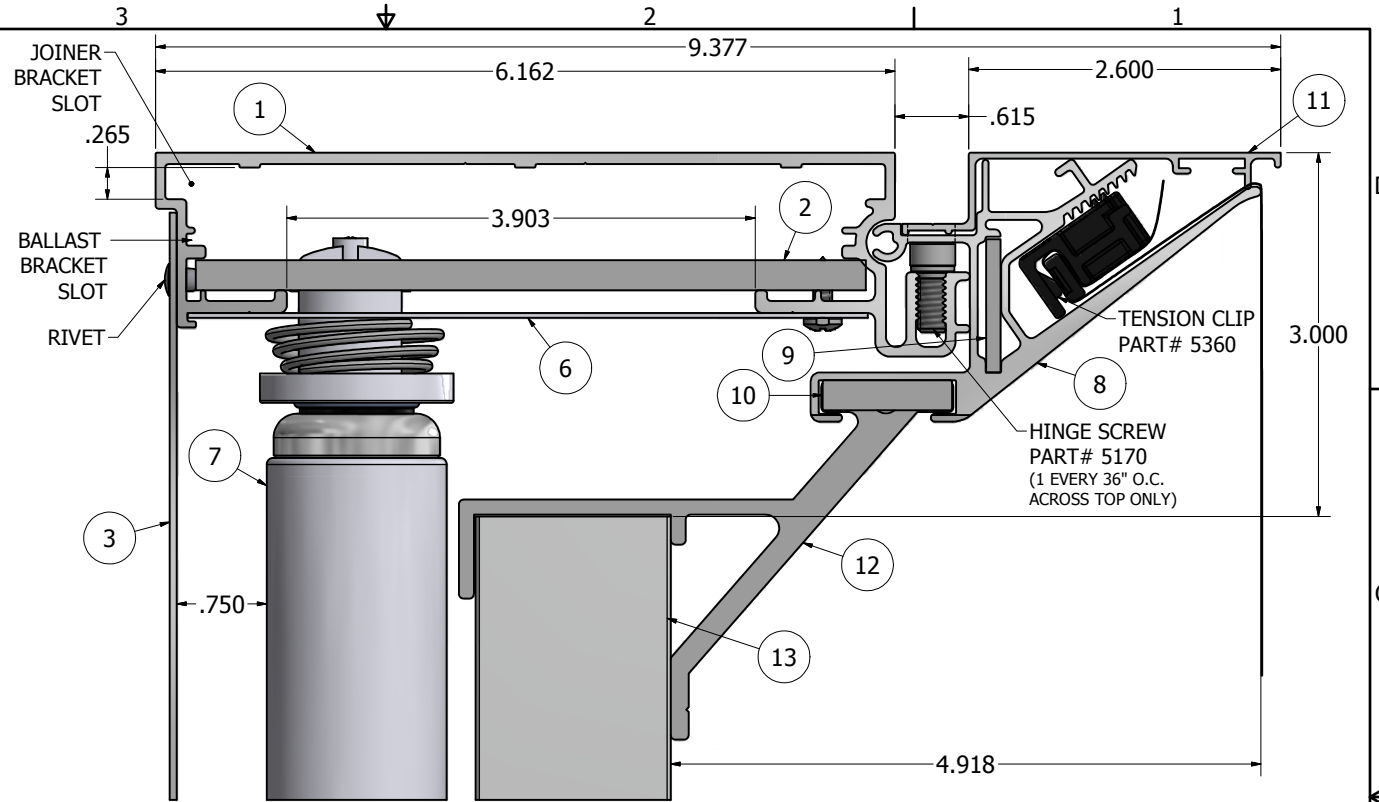

SECTION VIEW - ELECTRICAL

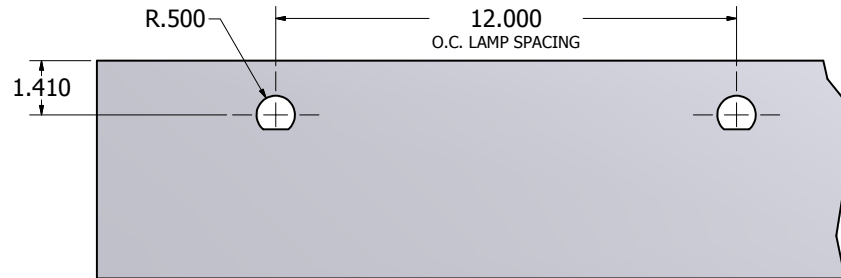

RACEWAY D-PUNCH DETAIL

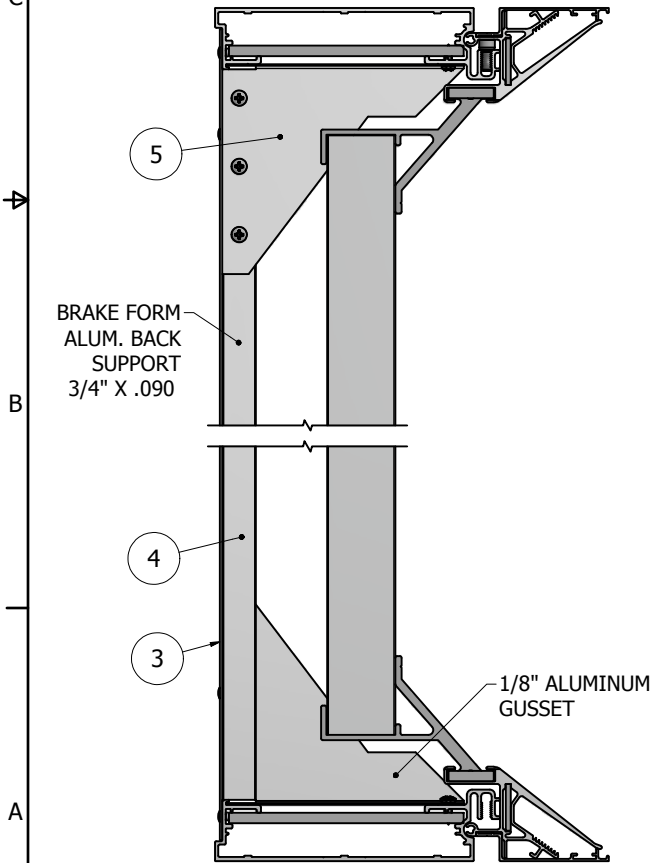

SECTION VIEW - STRUCTURAL

NOTES

1. ADD 1" TO SIZE OF CABINET (VERTICAL OR HORIZONTAL) WHEN THE SIZE OF THE CABINET IS THE SAME SIZE AS THE NOMINAL LAMP LENGTH.
2. SIGNCOMP DOES NOT SUPPLY THE BALLAST(S), LAMPS, LAMP SOCKETS OR THE ALUMINUM BACK.
3. SIGNCOMP DOES NOT SUPPLY THE MATERIAL FOR GUSSETS, 1/4" JOINER BRACKET OR ALUMINUM BACK.

THIS DRAWING WAS CREATED AT NO CHARGE TO ASSIST YOU IN VISUALIZING OUR PROPOSAL. THE DRAWING HEREIN IS THE PROPERTY OF SIGNCOMP. PERMISSION TO COPY OR REVISE THIS DRAWING OR TO USE THIS DRAWING FOR PRODUCTION IS STRICTLY PROHIBITED AND CAN ONLY BE COPIED, REVISED OR USED FOR PRODUCTION WITH THE EXPRESSED WRITTEN PERMISSION OF SIGNCOMP.

DRAWING BY:	SBreihof	6/10/2014
Centroid X:	0.000 in	
Centroid Y:	0.000 in	
Principal Moments Ix:	0.000 in ⁴	
Principal Moments Iy:	0.000 in ⁴	
Section Modulus Ix:	0.000 in ³	
Section Modulus Iy:	0.000 in ³	

SignComp		
TITLE		
Single Face Body with Tension Frame II and Bleed Cover - Cross Sectional Details		
PART NO	2025-86-95 with 5350	REV
SHEET 1 OF 1		