

ITEM	PART #	DESCRIPTION	NOTES
1	2107	Flat Bleed Retro Frame II	Assembly
2	2121	Flat Bleed Retro Cover	All Sides
3	By Other	Angle or Tubing	Required if not attaching to existing structure
4	By Other	Attachment Fastener	Not provided by SignComp
12	5195	Cover Screw	#8x5/16" Pre-drill 1/8" hole

**NOTE: PRE-CUT KITS ARE NOT PRE-DRILLED.**

(Holes shown in this drawing are for reference only. Drilling of pilot holes are to be done by fabricator.)

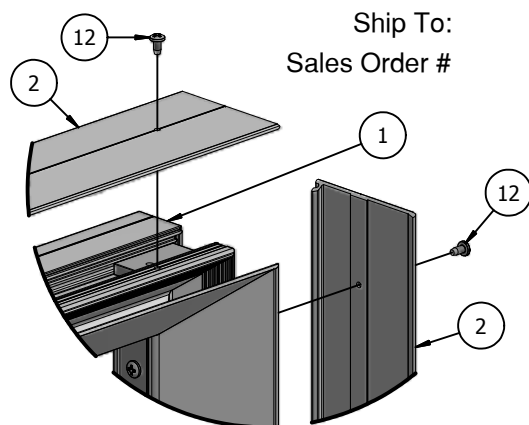
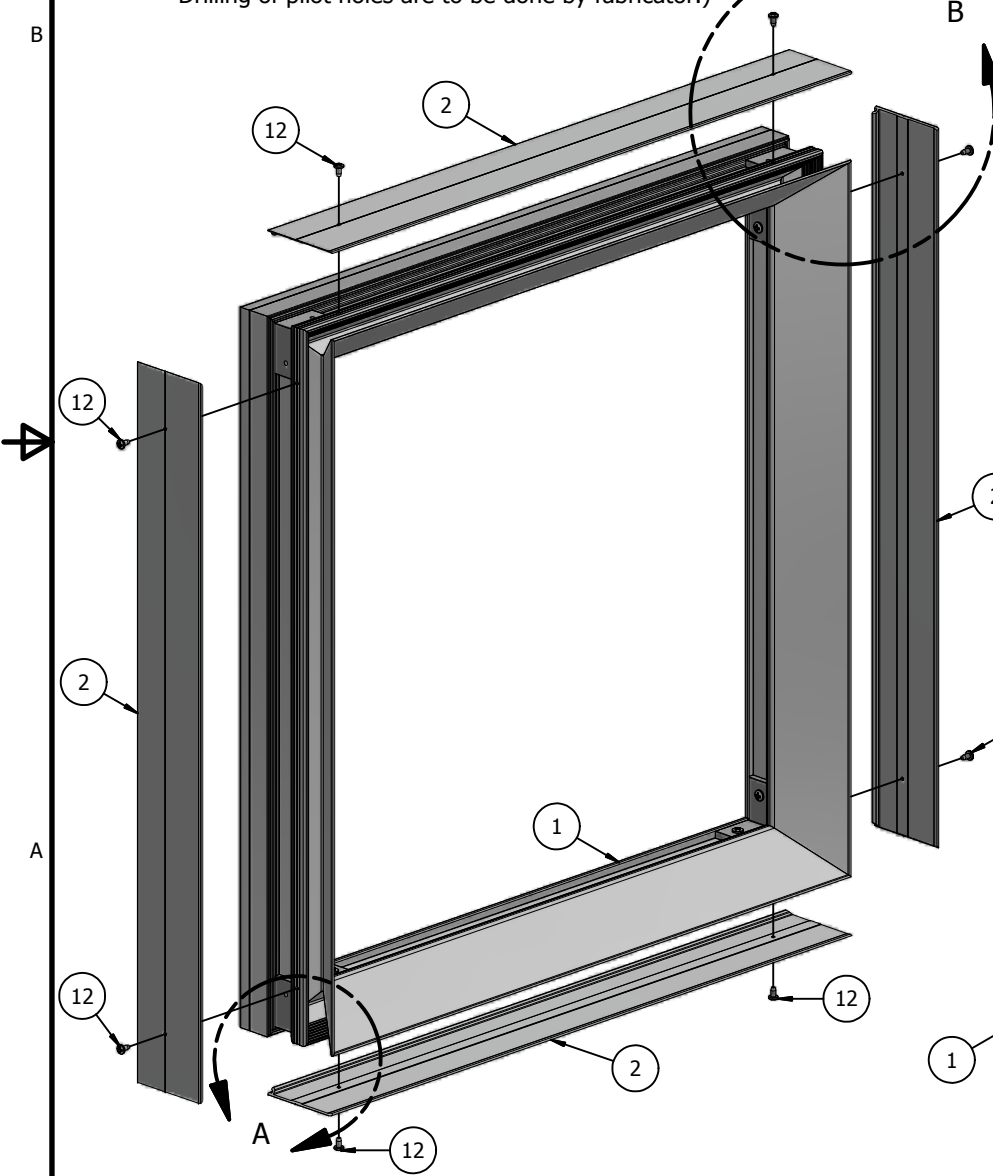

Ship To:  
Sales Order #

DETAIL B

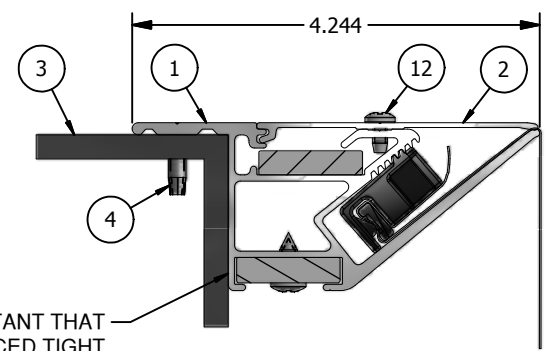

ASSEMBLY CROSS-SECTION

\*NOTE: IT'S IMPORTANT THAT THE FRAME IS PLACED TIGHT TO THE ANGLE MATERIAL BEFORE FASTENING.

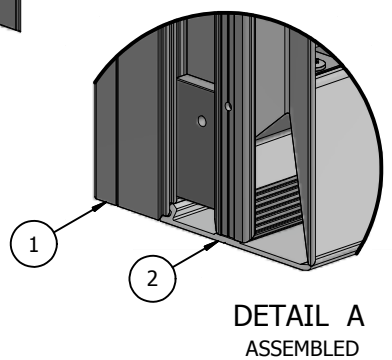

DETAIL A ASSEMBLED

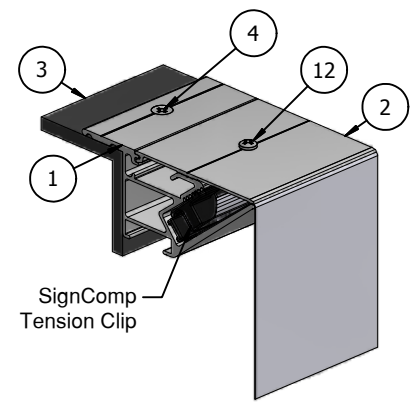

SignComp Tension Clip

THIS DRAWING WAS CREATED AT NO CHARGE TO ASSIST YOU IN VISUALIZING OUR PROPOSAL. THE DRAWING HEREIN IS THE PROPERTY OF SIGNCOMP. PERMISSION TO COPY OR REVISE THIS DRAWING OR TO USE THIS DRAWING FOR PRODUCTION IS STRICTLY PROHIBITED AND CAN ONLY BE COPIED, REVISED OR USED FOR PRODUCTION WITH THE EXPRESSED WRITTEN PERMISSION OF SIGNCOMP.

Part Name:	Flat Bleed Retro Frame II/Bleed Cover - Assembly
Part Number:	K2107-21
Revision:	
Date:	1/30/2015
Sheet:	1 of 1
Size:	A
Sheet:	1 of 1
Drawing By:	SBreihof



ITEM	PART #	DESCRIPTION	NOTES
1	2107	Flat Bleed Retro Frame II	Top & Bottom
2	2107	Flat Bleed Retro Frame II	Sides
3	5305	Frame Corner Angle	Two (2) per corner
13	5218	Corner Angle Screw	#10 x 1/2" pan head tapping

Ship To:  
Sales Order #

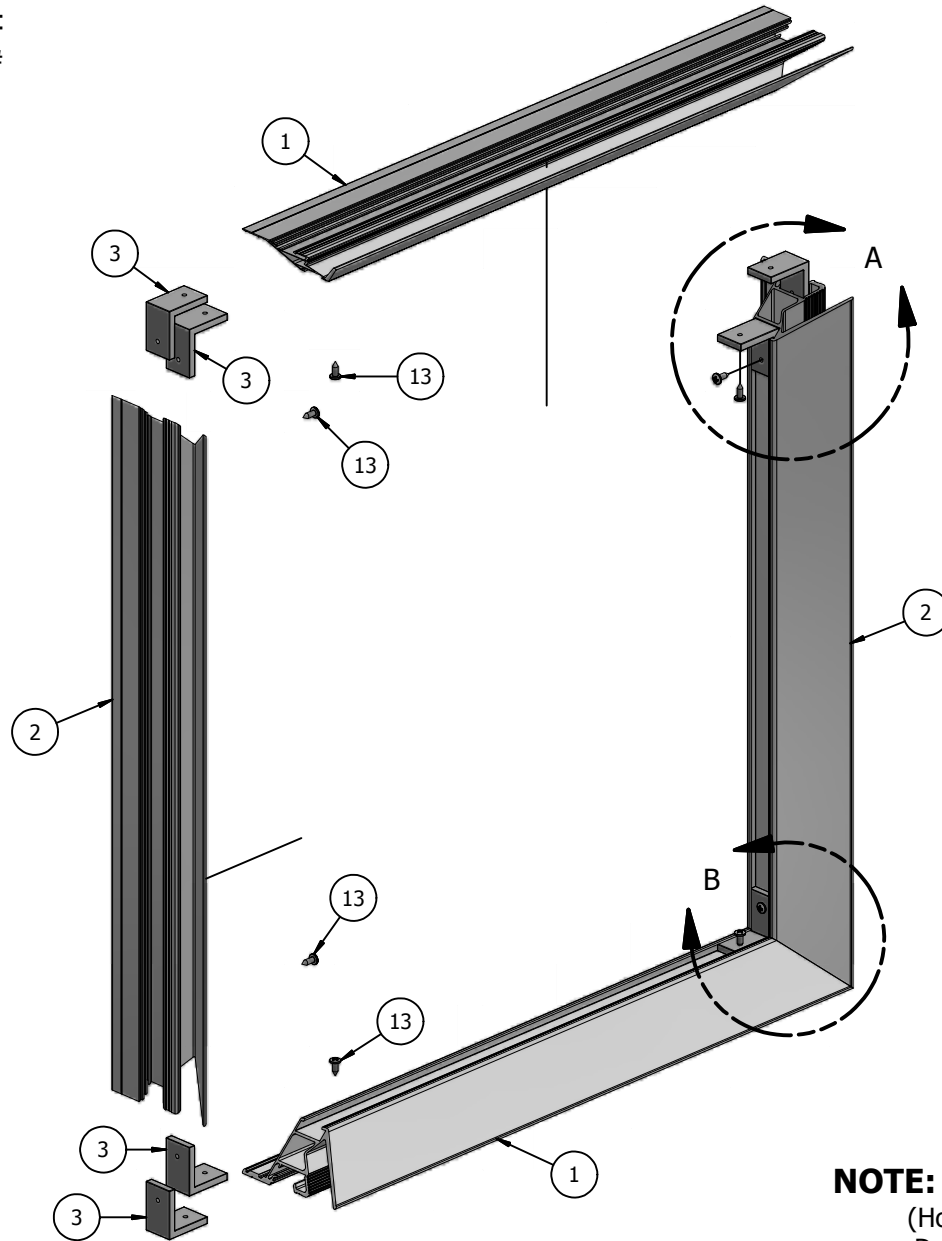

THE OUTER FRAME  
CORNER ANGLE FLOATS  
IN THE FRAME FOR  
ALIGNMENT.

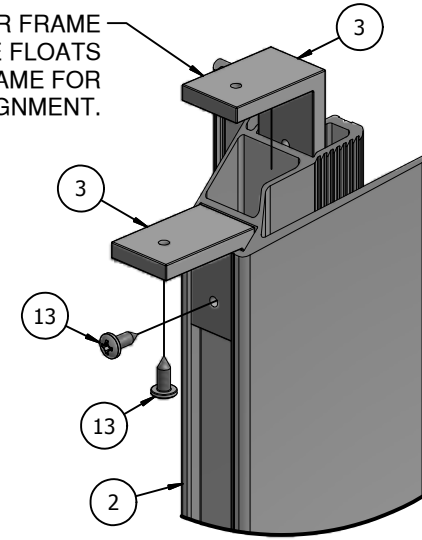

DETAIL A

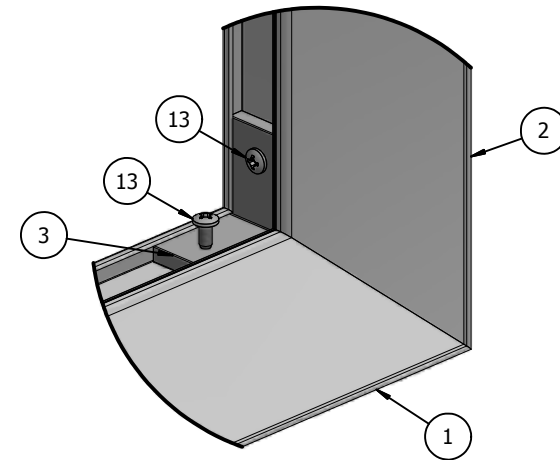

DETAIL B

**NOTE: PRE-CUT KITS ARE NOT PRE-DRILLED.**

(Holes shown in this drawing are for reference only.  
Drilling of pilot holes are to be done by fabricator.)

THIS DRAWING WAS CREATED AT NO CHARGE TO ASSIST YOU IN VISUALIZING OUR PROPOSAL. THE DRAWING HEREIN IS THE PROPERTY OF SIGNCOMP. PERMISSION TO COPY OR REVISE THIS DRAWING OR TO USE THIS DRAWING FOR PRODUCTION IS STRICTLY PROHIBITED AND CAN ONLY BE COPIED, REVISED OR USED FOR PRODUCTION WITH THE EXPRESSED WRITTEN PERMISSION OF SIGNCOMP.

Part Name: Flat Bleed Retro Frame II - Assembly

Part Number: K2107

Revision:

Date: 1/30/2015

Drawing By: SBreihof

Sheet: 1 of 1

Size: A

**SignComp**