

PARTS LIST			
ITEM	PART#	DESCRIPTION	NOTES
1	K2005	Wide Body	Assembly
2	K2053/63/73	1 1/2" Retainer w/ Frame and Cover	Assembly
10	5170	Hinge Screw	Drill 3/8" pilot hole
11	5180	Closure Screw	Drill 5/16" pilot hole

Ship To:  
Sales Order#

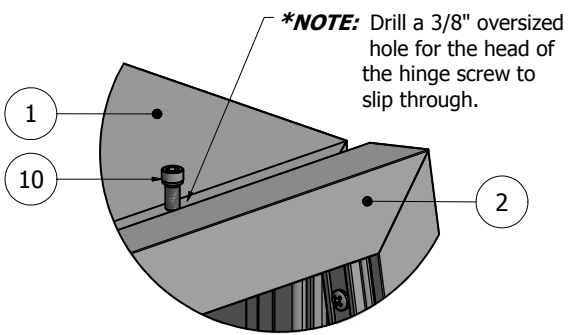

DETAIL A

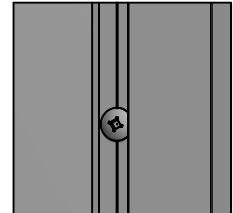
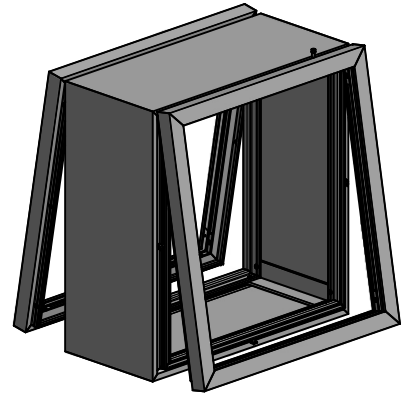

DETAIL B  
FRAME CLOSED

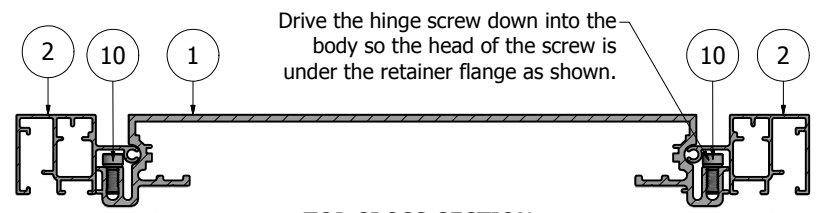
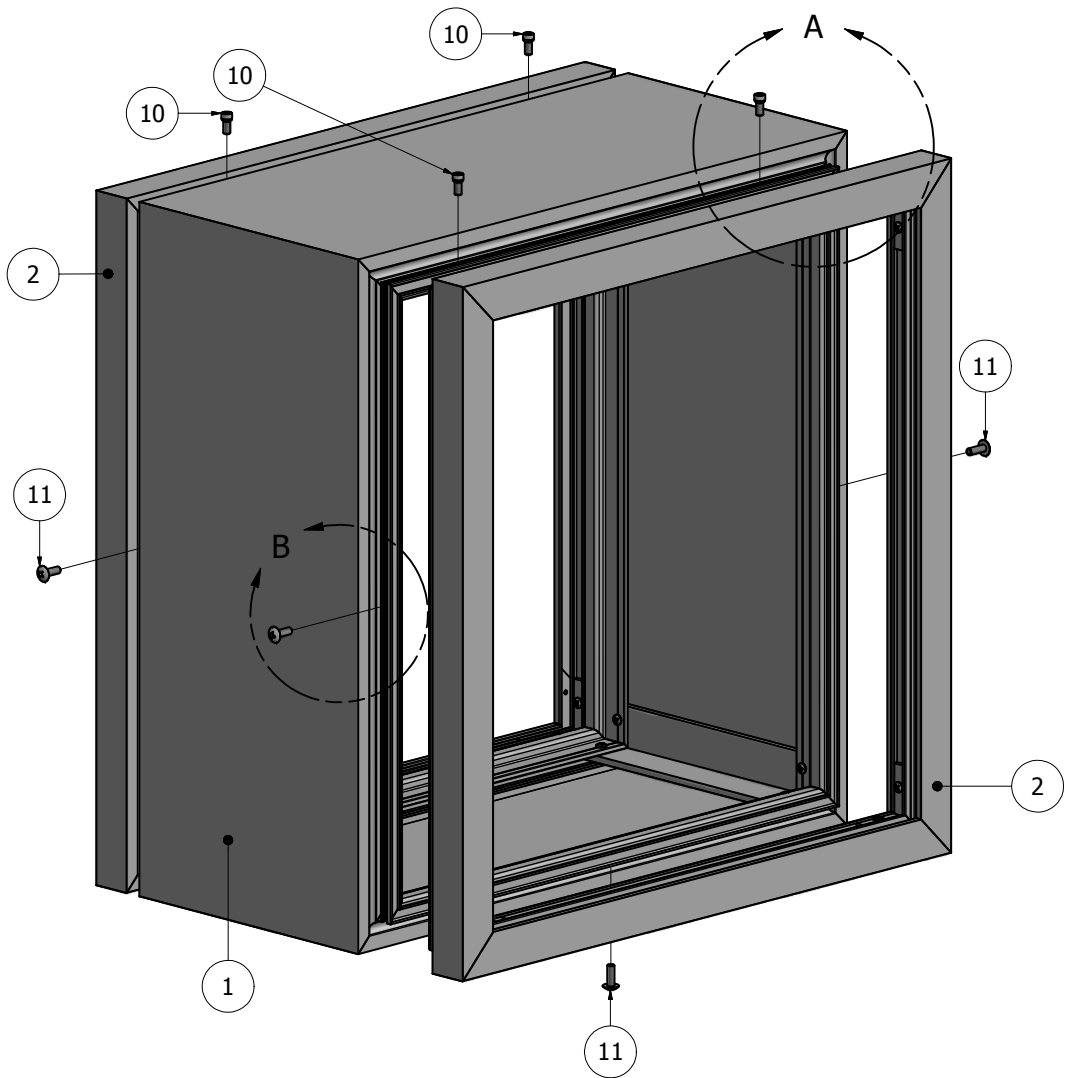

TOP CROSS-SECTION

**NOTE: PRE-CUT KITS ARE NOT PRE-DRILLED.**  
(Holes shown in this drawing are for reference only.  
Drilling of pilot holes are to be done by fabricator.)

THIS DRAWING WAS CREATED AT NO CHARGE TO ASSIST YOU IN VISUALIZING OUR PROPOSAL. THE DRAWING HEREIN IS THE PROPERTY OF SIGNCOMP. PERMISSION TO COPY OR REVISE THIS DRAWING OR TO USE THIS DRAWING FOR PRODUCTION IS STRICTLY PROHIBITED AND CAN ONLY BE COPIED, REVISED OR USED FOR PRODUCTION WITH THE EXPRESSED WRITTEN PERMISSION OF SIGNCOMP.

DRAWN	SBreihof	10/30/2012	<b>SignComp</b>
Centroid X:	0.000 in		
Centroid Y:	0.000 in		
Principal Moments Ix:	0.000 in <sup>4</sup>		Wide Body w/ 1 1/2" Retainer - Assembly
Principal Moments Iy:	0.000 in <sup>4</sup>		
Section Modulus Ix:	0.000 in <sup>3</sup>		DWG NO <b>KWB-53 with 2063</b> REV
Section Modulus Iy:	0.000 in <sup>3</sup>		

Parts List			
ITEM	PART #	DESCRIPTION	NOTES
1	2005	Wide Body	Top & Bottom
2	2005	Wide Body	Sides
3	5312	Wide Body Corner Angle	
13	5218	Corner Angle Screw	Drill 5/32" pilot hole

Ship To:  
Order Number:

D

C

B

B

A

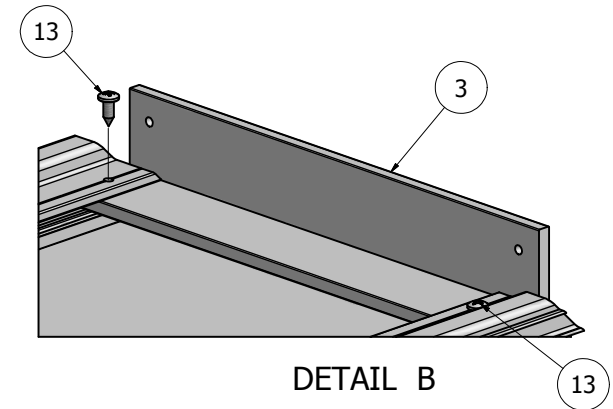
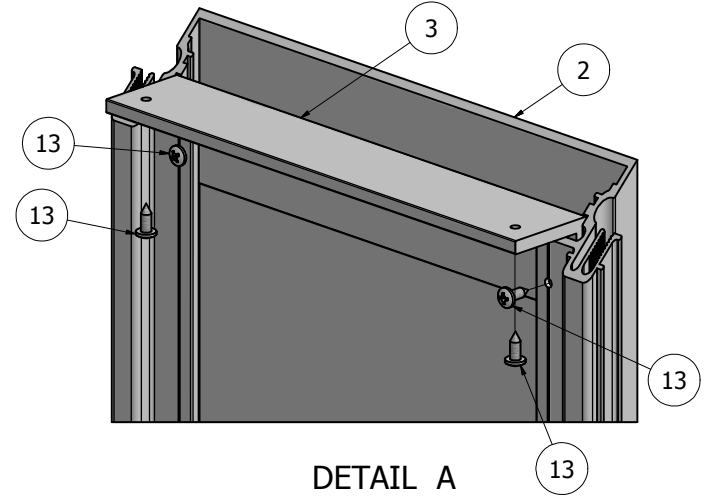
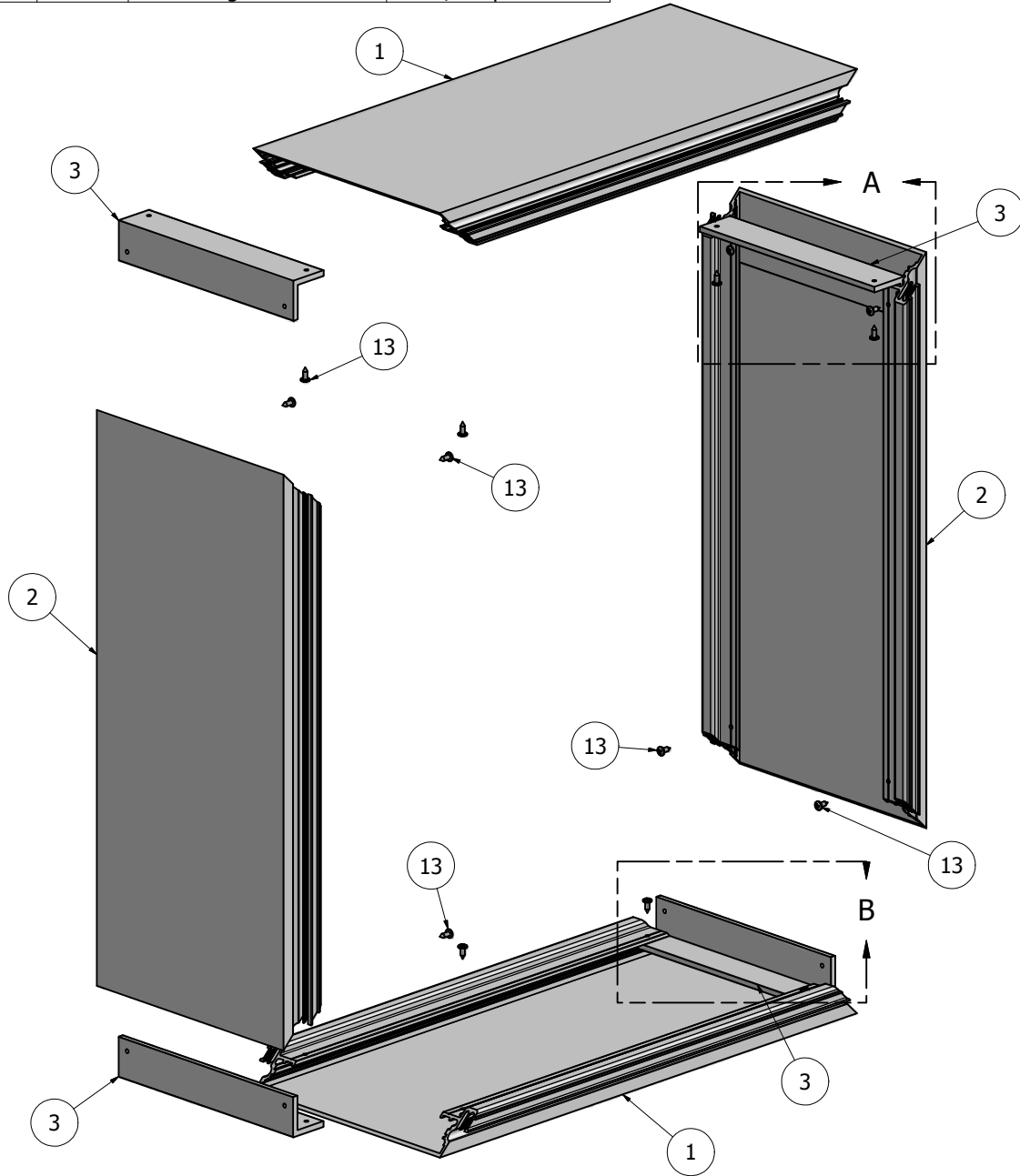

**NOTE: PRE-CUT KITS ARE NOT PRE-DRILLED.**

(Holes shown in this drawing are for reference only.  
Drilling of pilot holes are to be done by fabricator.)

THIS DRAWING WAS CREATED AT NO CHARGE TO ASSIST YOU IN VISUALIZING OUR PROPOSAL. THE DRAWING HEREIN IS THE PROPERTY OF SIGNCOMP. PERMISSION TO COPY OR REVISE THIS DRAWING OR TO USE THIS DRAWING FOR PRODUCTION IS STRICTLY PROHIBITED AND CAN ONLY BE COPIED, REVISED OR USED FOR PRODUCTION WITH THE EXPRESSED WRITTEN PERMISSION OF SIGNCOMP.

DRAWN	Sarah	3/5/2012	<b>SignComp</b>	
Centroid X:	0.000 in			
Centroid Y:	0.000 in		Wide Body - Assembly	
Principal Moments Ix:	0.000 in <sup>4</sup>			
Principal Moments Iy:	0.000 in <sup>4</sup>		DWG NO <b>K2005</b> REV	
Section Modulus Ix:	0.000 in <sup>3</sup>			
Section Modulus Iy:	0.000 in <sup>3</sup>		SHEET 1 OF 1	

D

C

B

B

A

PARTS LIST			
ITEM	PART #	DESCRIPTION	NOTES
1	2053	1 1/2" Retainer	Top & Bottom
2	2053	1 1/2" Retainer	One Side
3	2073	1 1/2" Frame Cover	One Side
4	2063	1 1/2" Frame	One Side
5	5304	1 1/2" Frame Corner Angle	
6	5210	Corner Key	
12	5195	Cover Screw	Pre-drill 3/32" pilot hole
13	5218	Corner Angle Screw	Drill 5/32" pilot hole

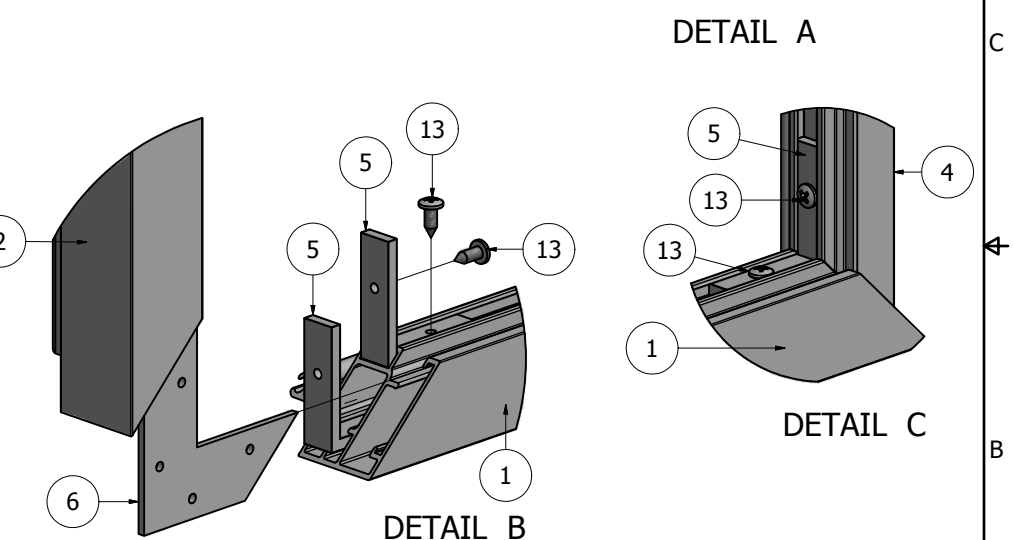
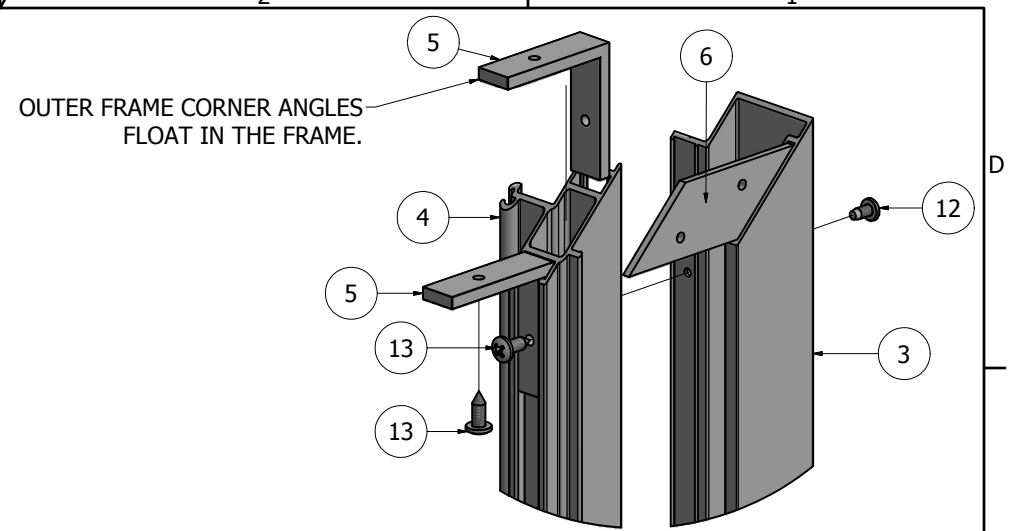
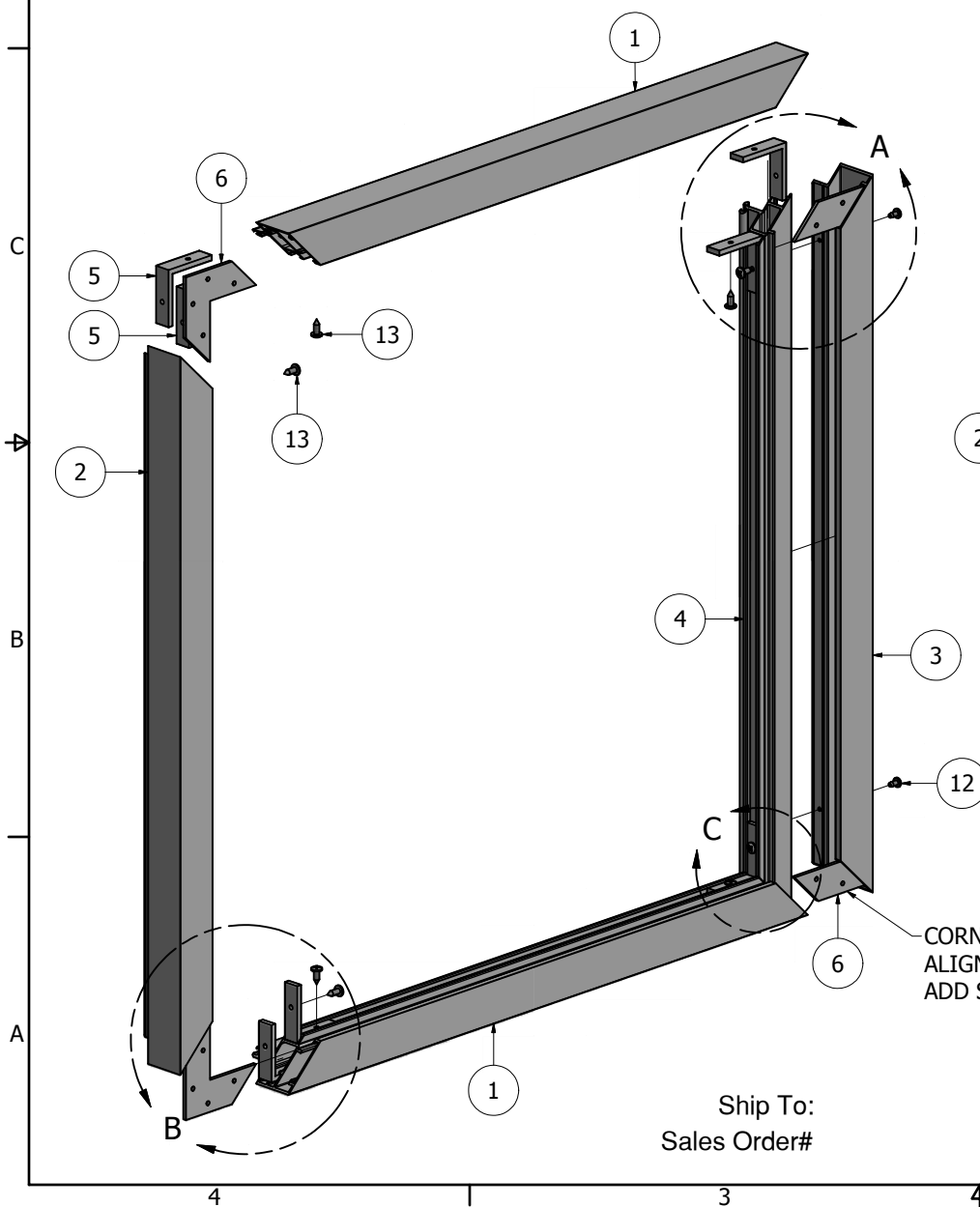

CORNER KEYS HELP ALIGN MITRES AND ADD STRENGTH.

Ship To:  
Sales Order#

THIS DRAWING WAS CREATED AT NO CHARGE TO ASSIST YOU IN VISUALIZING OUR PROPOSAL. THE DRAWING HEREIN IS THE PROPERTY OF SIGNCOMP. PERMISSION TO COPY OR REVISE THIS DRAWING OR TO USE THIS DRAWING FOR PRODUCTION IS STRICTLY PROHIBITED AND CAN ONLY BE COPIED, REVISED OR USED FOR PRODUCTION WITH THE EXPRESSED WRITTEN PERMISSION OF SIGNCOMP.

DRAWN	SBreihof	10/26/2012	<b>SignComp</b>
Centroid X:	0.000 in		
Centroid Y:	0.000 in		TITLE
Principal Moments Ix:	0.000 in <sup>4</sup>		1-1/2" Retainer w/ 1-1/2" Frame and Cover - Assembly
Principal Moments Iy:	0.000 in <sup>4</sup>		DWG NO
Section Modulus Ix:	0.000 in <sup>3</sup>		<b>K2053-63</b>
Section Modulus Iy:	0.000 in <sup>3</sup>		REV