

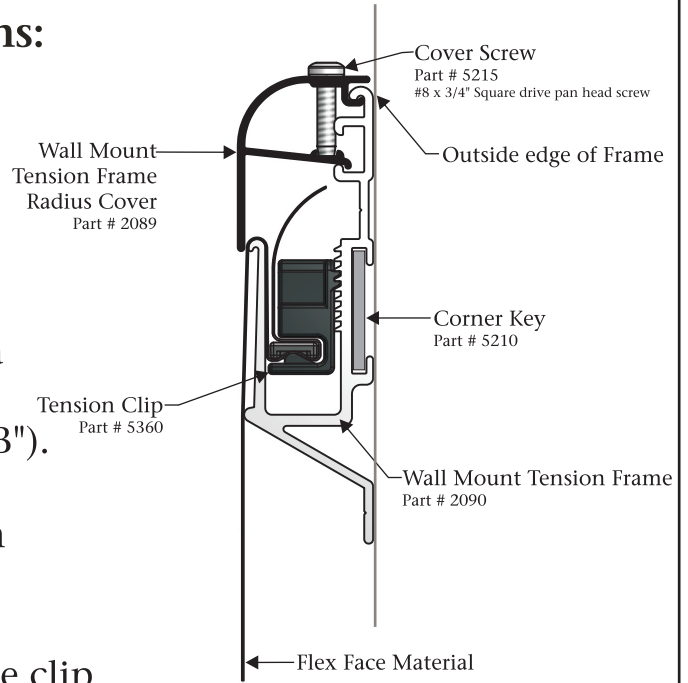

Face Measurement and Preparation
 Instructions for Wall Mount Tension Frame
 Part # 2090

Measurement and Preparation Instructions:

- Step 1:
Place fabric with graphic or copy side up.
- Step 2:
Measure height and width from outside edge of frame (See "A").
- Step 3:
Add 2-1/4" of fabric to all four sides (adding a total of 4-1/2" to both the height and width) to establish the trimmed edge of fabric (See "B").
- Step 4:
Draw a clip placement line (See "C") 2-1/4" in from trimmed edge of fabric (See "B").
- Step 5:
Place the Tension Clip Mandrel just inside the clip placement line smooth side up.



Tension Clip
Part #5360

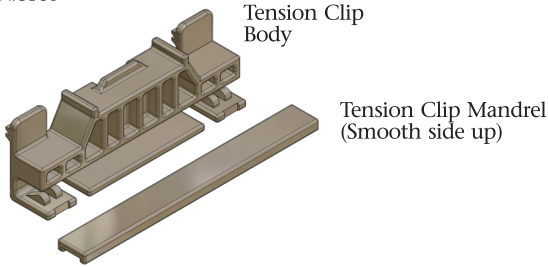

The Wall Mount Tension Frame requires either the Wall Mount Tensioning Tool, Part # 5137 or the Reverse Wall Mount Tensioning Tool, Part # 5138.

