

PARTS LIST			
ITEM	PART#	DESCRIPTION	NOTES
1	K2015/4075	Medium Body w/ 6in Radius Corners	Assembly
2	K2055/4285	1 1/2" Retainer w/ 6in Radius Corners	Assembly
10	5170	Hinge Screw	Drill 3/8" pilot hole
11	5180	Closure Screw	Drill 5/16" pilot hole

Ship To:
Sales Order#

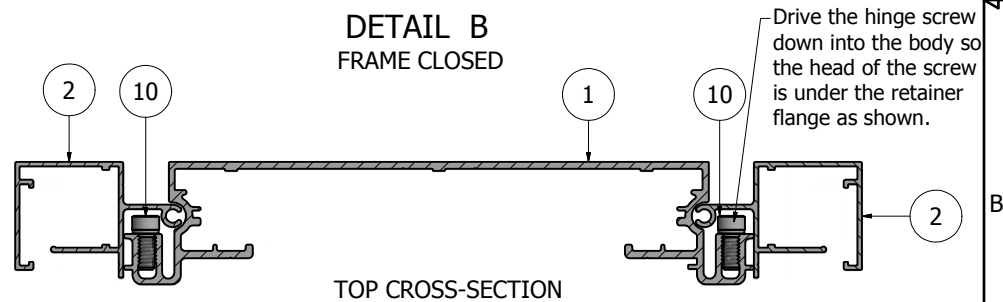
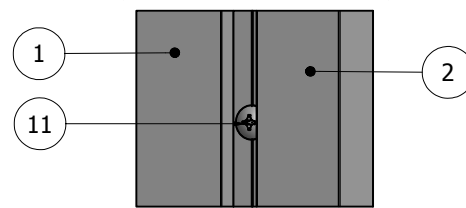
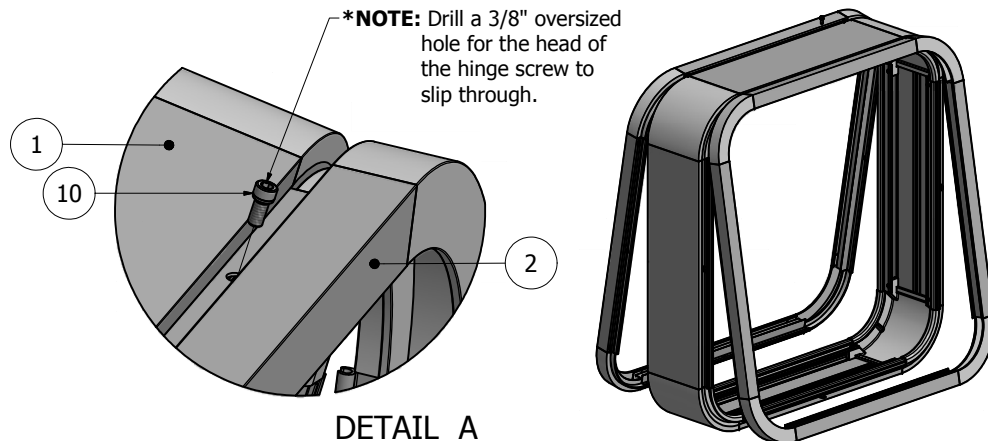
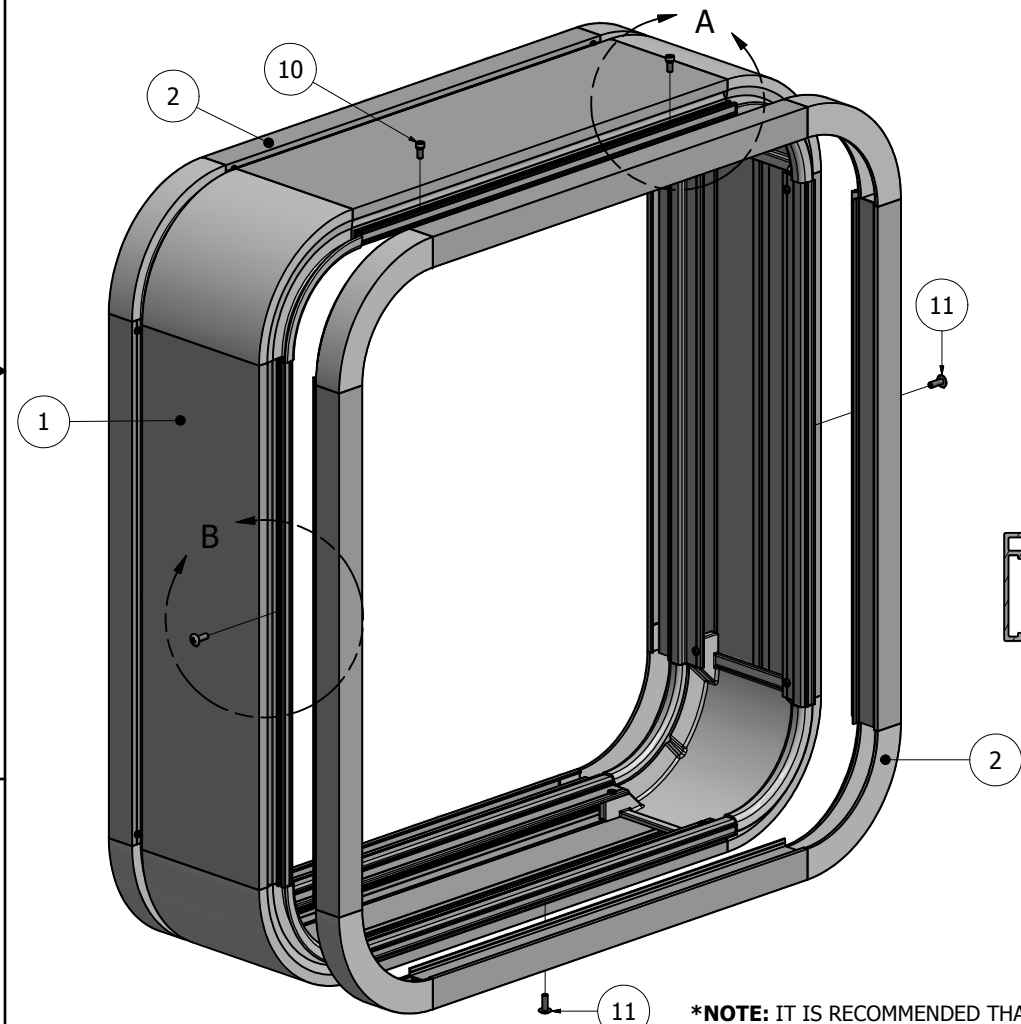

NOTE: PRE-CUT KITS ARE NOT PRE-DRILLED.
(Holes shown in this drawing are for reference only. Drilling of pilot holes are to be done by fabricator.)

***NOTE:** IT IS RECOMMENDED THAT THE FRAME BE ASSEMBLED ON THE BODY, THEN RATCHET STRAPPED TO CHECK FOR SQUARE, BEFORE THE FRAME IS WELDED OR MECHANICALLY ASSEMBLED.

THIS DRAWING WAS CREATED AT NO CHARGE TO ASSIST YOU IN VISUALIZING OUR PROPOSAL. THE DRAWING HEREIN IS THE PROPERTY OF SIGNCOMP. PERMISSION TO COPY OR REVISE THIS DRAWING OR TO USE THIS DRAWING FOR PRODUCTION IS STRICTLY PROHIBITED AND CAN ONLY BE COPIED, REVISED OR USED FOR PRODUCTION WITH THE EXPRESSED WRITTEN PERMISSION OF SIGNCOMP.

DRAWN	SBreihof	11/8/2012	SignComp
Centroid X:	0.000 in		
Centroid Y:	0.000 in		TITLE
Principal Moments Ix:	0.000 in ⁴		Medium Body w/ 1 1/2" Retainer and 6in Radius Corners - Assembly
Principal Moments Iy:	0.000 in ⁴		DWG NO
Section Modulus Ix:	0.000 in ³		KMB/55/4535
Section Modulus Iy:	0.000 in ³		REV

PARTS LIST			
ITEM	PART#	DESCRIPTION	NOTES
1	2015	Medium Body	Top & Bottom
2	2015	Medium Body	Sides
3	4075	Medium Body 6in Radius Corner	
65	5218	Radius Corner Screw	Drill 5/32" pilot hole

Ship To:
Sales Order#

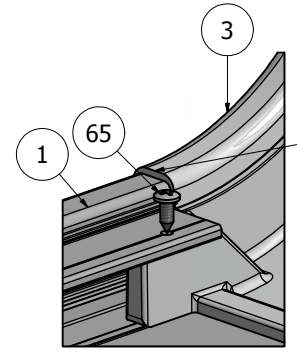
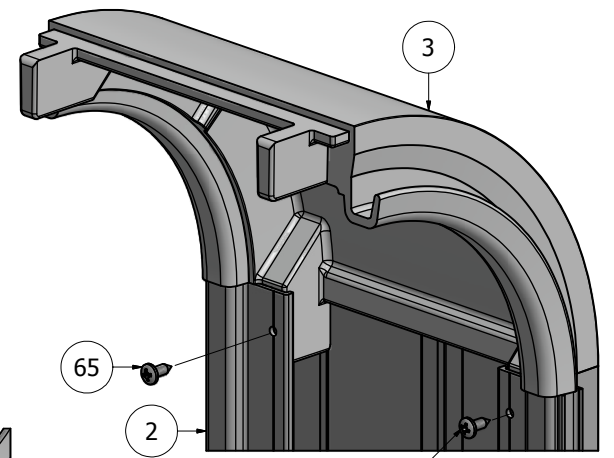
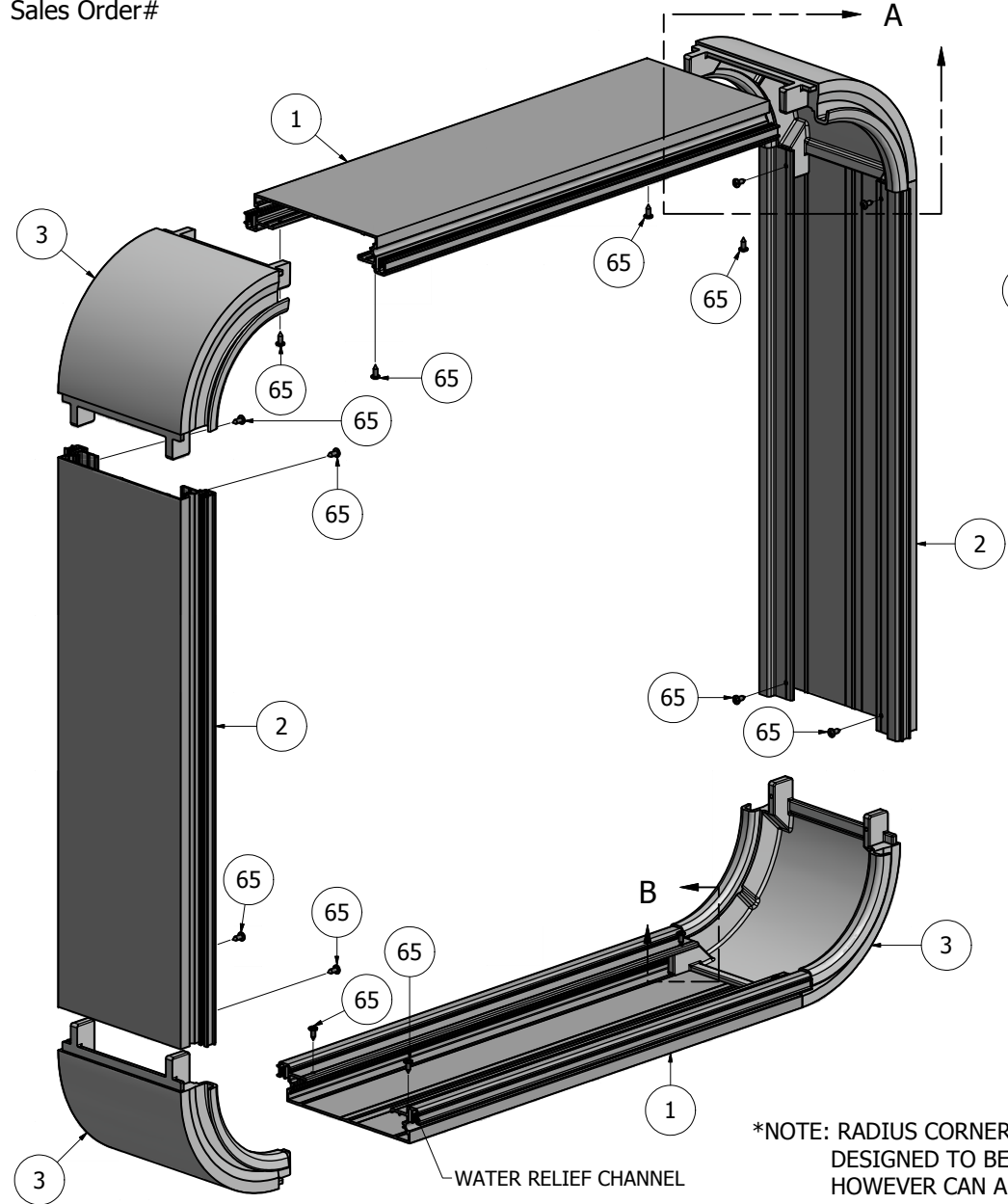

Caulk the joints where the Radius Diecast Corners and the Extrusion meet, yet making sure the water relief channel is not blocked, allowing the water to flow.

DETAIL A

DETAIL B

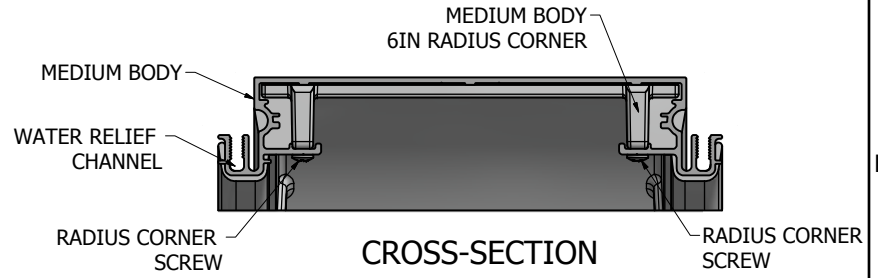

CROSS-SECTION

NOTE: PRE-CUT KITS ARE NOT PRE-DRILLED.
(Holes shown in this drawing are for reference only. Drilling of pilot holes are to be done by fabricator.)

*NOTE: RADIUS CORNERS ARE DESIGNED TO BE WELDED, HOWEVER CAN ALSO BE MECHANICALLY ASSEMBLED.

THIS DRAWING WAS CREATED AT NO CHARGE TO ASSIST YOU IN VISUALIZING OUR PROPOSAL. THE DRAWING HEREIN IS THE PROPERTY OF SIGNCOMP. PERMISSION TO COPY OR REVISE THIS DRAWING OR TO USE THIS DRAWING FOR PRODUCTION IS STRICTLY PROHIBITED AND CAN ONLY BE COPIED, REVISED OR USED FOR PRODUCTION WITH THE EXPRESSED WRITTEN PERMISSION OF SIGNCOMP.			
DRAWN	SBreihof	10/23/2012	SignComp
Centroid X:	0.000 in		
Centroid Y:	0.000 in		TITLE
Principal Moments Ix:	0.000 in ⁴		Medium Body w/ 6in Radius Corners - Assembly
Principal Moments Iy:	0.000 in ⁴		DWG NO
Section Modulus Ix:	0.000 in ³		KMB-4075
Section Modulus Iy:	0.000 in ³		REV
			SHEET 1 OF 1

PARTS LIST			
ITEM	PART#	DESCRIPTION	NOTES
1	2055	1 1/2" Retainer	Top & Bottom
2	2055	1 1/2" Retainer	Sides
3	4285	1 1/2" Retainer 6in Radius Corner	All 4 Corners
72	5195	Radius Corner Retainer Screw	Drill 1/8" pilot hole

Ship To:
Sales Order#

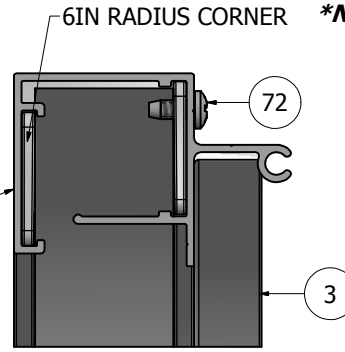
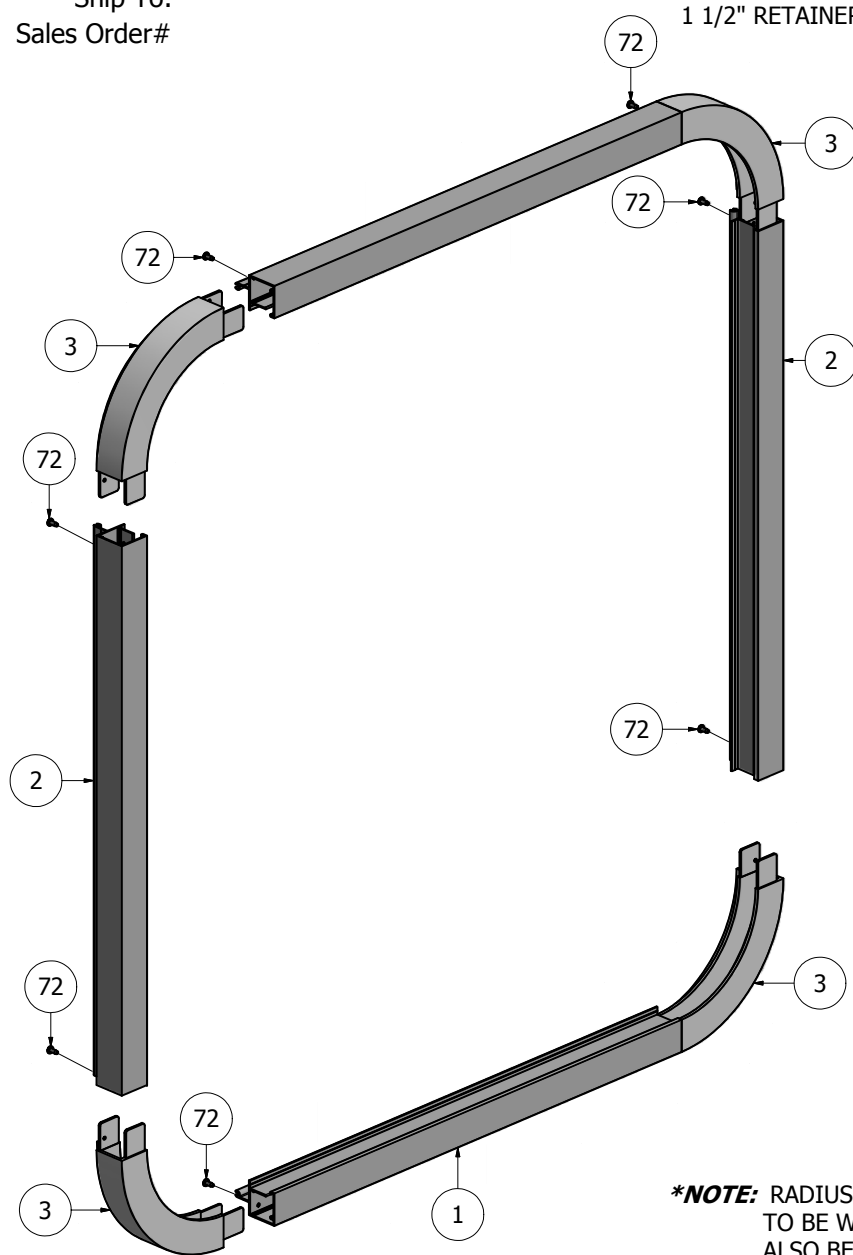

DETAIL C
CROSS-SECTION

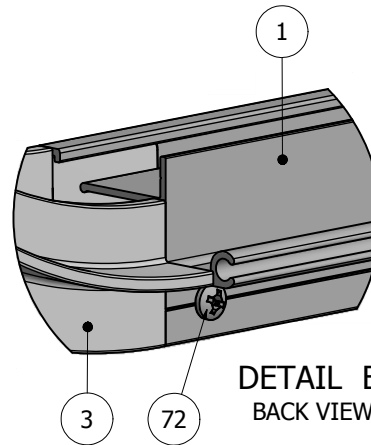

DETAIL B
BACK VIEW

***NOTE:** THE SIDES OF THE TABS ARE MILLED TO FIT TIGHT TO THE RETAINER BEFORE WELDING OR FASTENING.

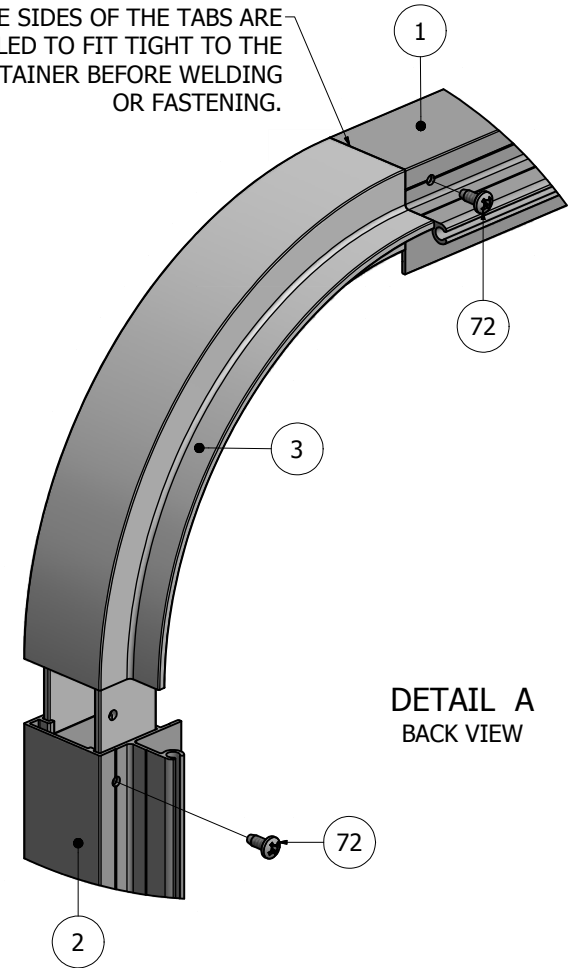

DETAIL A
BACK VIEW

***NOTE: PRE-CUT KITS ARE NOT PRE-DRILLED.**
(Holes shown in this drawing are for reference only.
Drilling of pilot holes are to be done by fabricator.)

THIS DRAWING WAS CREATED AT NO CHARGE TO ASSIST YOU IN VISUALIZING OUR PROPOSAL. THE DRAWING HEREIN IS THE PROPERTY OF SIGNCOMP. PERMISSION TO COPY OR REVISE THIS DRAWING OR TO USE THIS DRAWING FOR PRODUCTION IS STRICTLY PROHIBITED AND CAN ONLY BE COPIED, REVISED OR USED FOR PRODUCTION WITH THE EXPRESSED WRITTEN PERMISSION OF SIGNCOMP.

DRAWN	SBreihof	10/25/2012	SignComp
Centroid X:	0.000 in	TITLE	
Centroid Y:	0.000 in	1 1/2" Retainer with 6in Radius Corners - Assembly	
Principal Moments Ix:	0.000 in ⁴	DWG NO	REV
Principal Moments Iy:	0.000 in ⁴	2055-4285	
Section Modulus Ix:	0.000 in ³	SHEET 1 OF 1	
Section Modulus Iy:	0.000 in ³		

***NOTE:** RADIUS CORNERS ARE DESIGNED TO BE WELDED, HOWEVER CAN ALSO BE MECHANICALLY ASSEMBLED.