

Parts List			
ITEM	PART #	DESCRIPTION	NOTES
1	1100	Series 2 Square Post	
2	1200	Series 2/3 Reveal	Attached to body
3	Post Cap	Series 2 Square Post Cap	Zero Reveal Part #5260, 3/8" Reveal Part #5261, 3/4" Reveal Part #5262
41	5040	Post Cap Screw	2 - #10 x 1/2" counter sunk phillips head screws
5	K1120/00	Series 2 Bleed Body - Assembly	Slide assembly into post

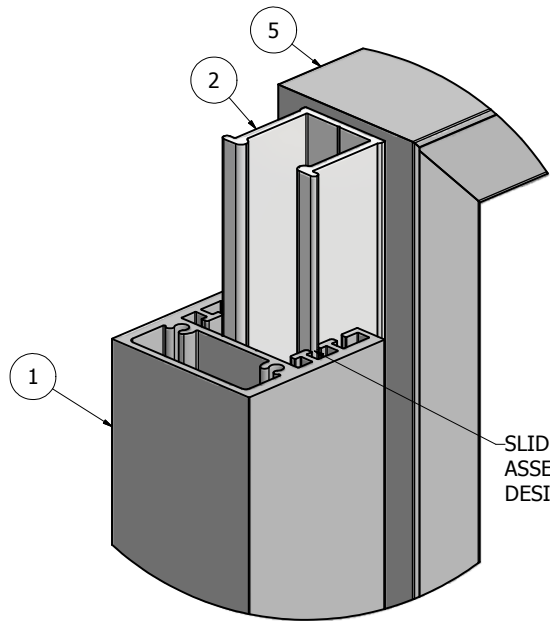

DETAIL B

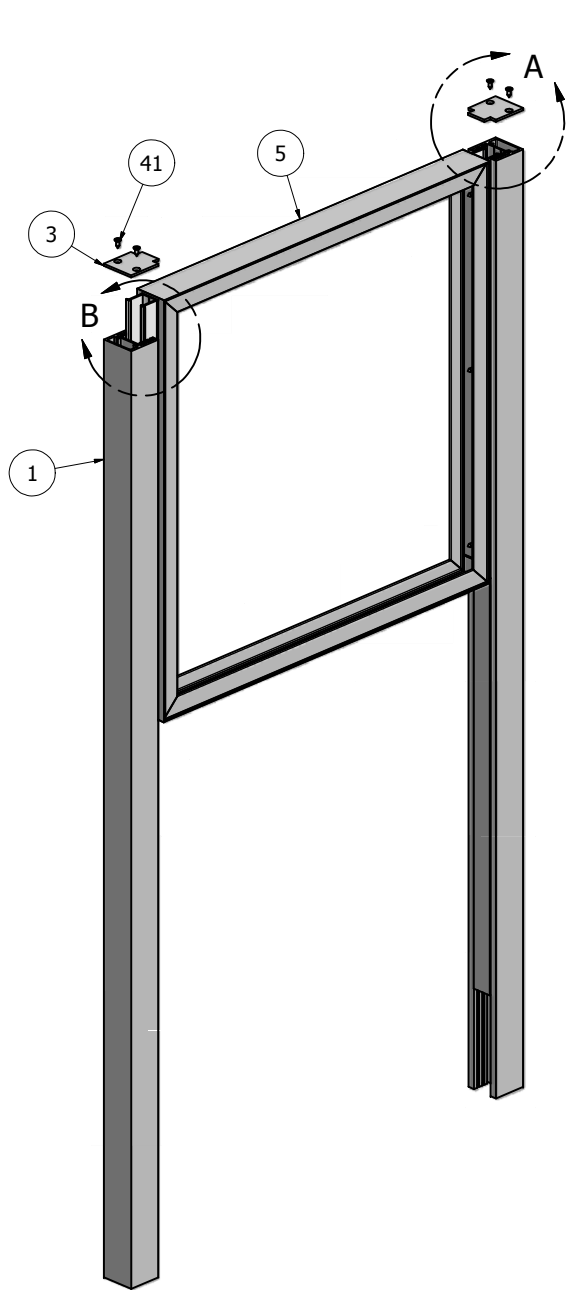
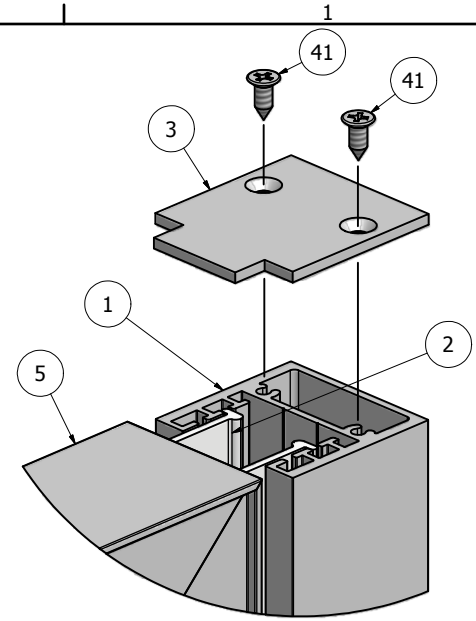

DETAIL A

SLIDE BODY/CABINET ASSEMBLY INTO THE DESIRED REVEAL POSITION.

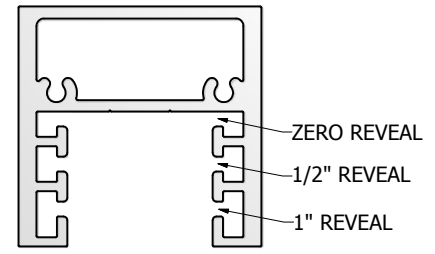
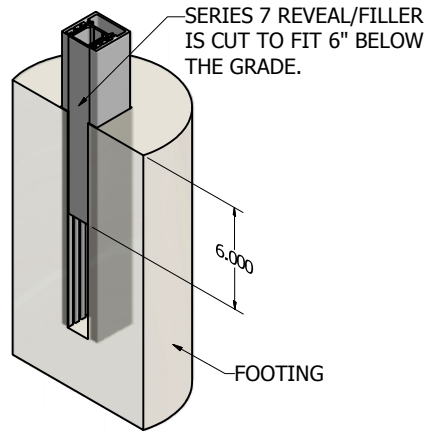

NOTE: PRE-CUT KITS ARE NOT PRE-DRILLED.
 (Holes shown in this drawing are for reference only.
 Drilling of pilot holes are to be done by fabricator.)

THIS DRAWING WAS CREATED AT NO CHARGE TO ASSIST YOU IN VISUALIZING OUR PROPOSAL. THE DRAWING HEREIN IS THE PROPERTY OF SIGNCOMP. PERMISSION TO COPY OR REVISE THIS DRAWING OR TO USE THIS DRAWING FOR PRODUCTION IS STRICTLY PROHIBITED AND CAN ONLY BE COPIED, REVISED OR USED FOR PRODUCTION WITH THE EXPRESSED WRITTEN PERMISSION OF SIGNCOMP.

DRAWN Steve	3/31/2010	SignComp	
CHECKED			
QA		TITLE Series 2 Bleed Body - Series 2 Square Post - Assembly	
MFG		SIZE C	DWG NO K1100-20-00
APPROVED		SCALE	REV
		SHEET 1 OF 1	

Ship To:
Order #:

Parts List			
ITEM	PART #	DESCRIPTION	NOTES
1	K1120	Series 2 Bleed Body	Assembly
2	1200	Series 2/3 Reveal	Attach to Bleed Body
42	5220	Reveal to Body Screw	Drill 5/32" pilot hole 12" OC

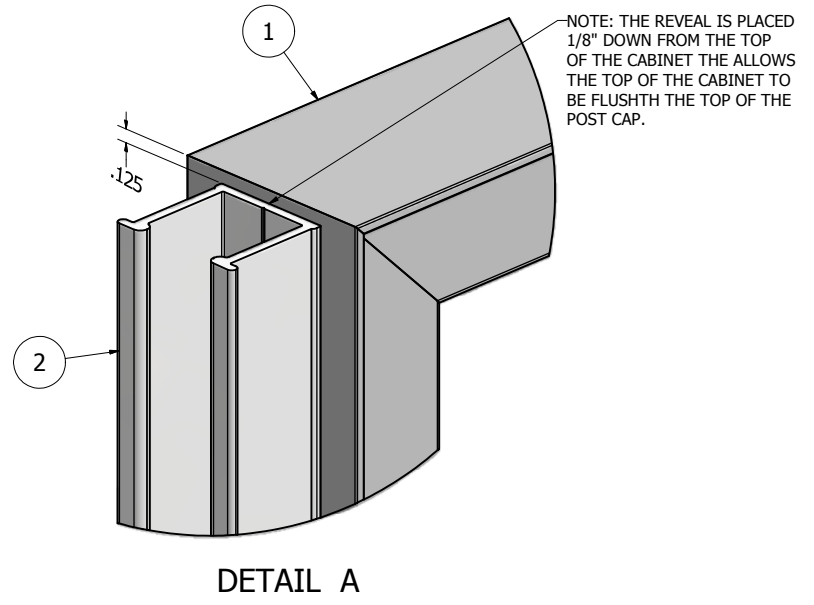
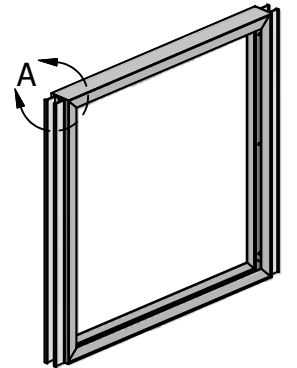
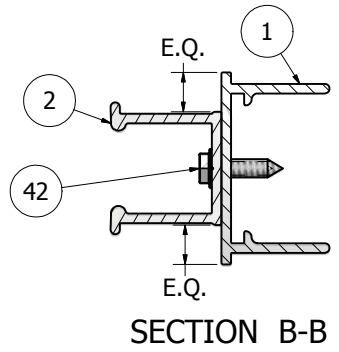
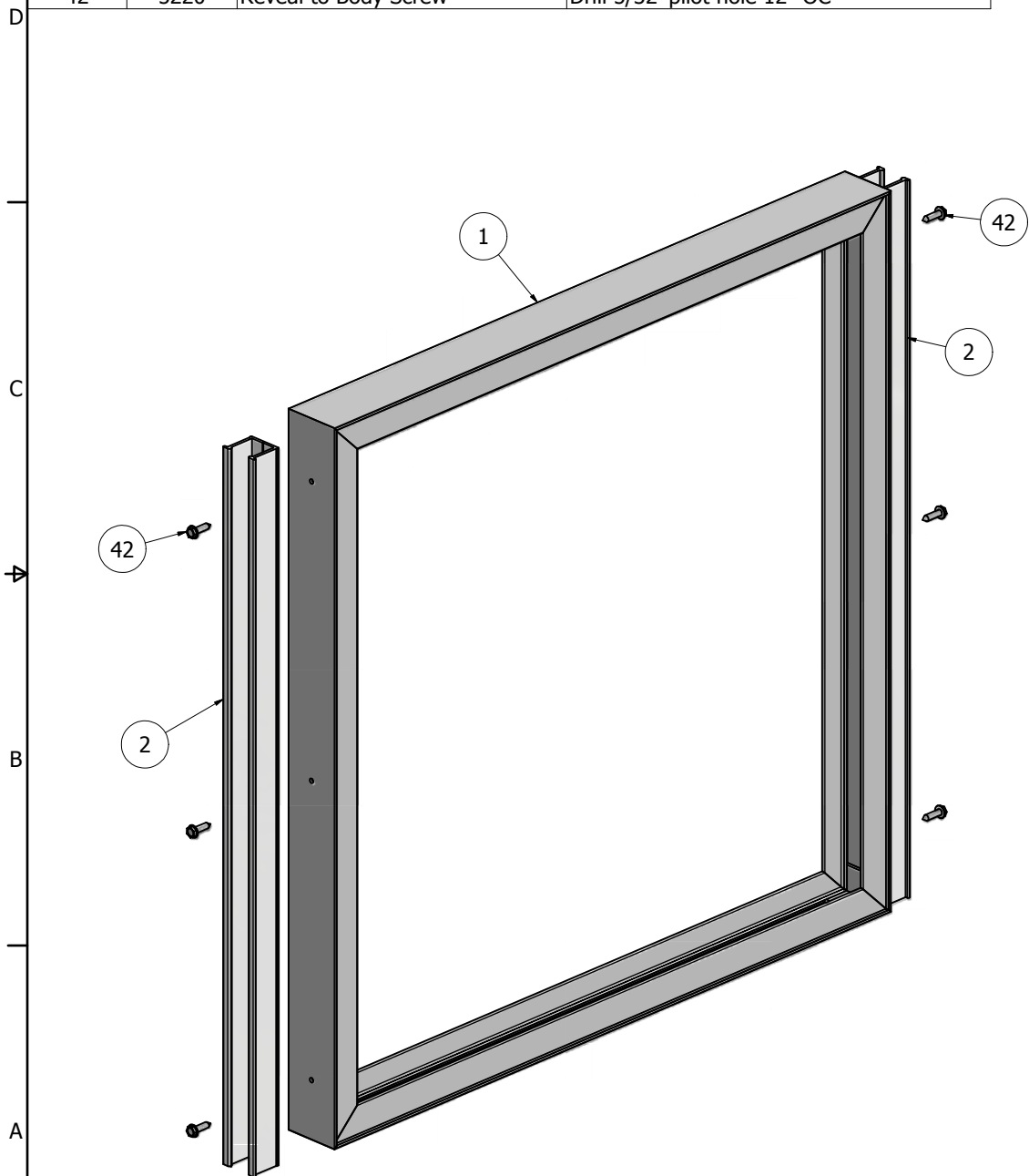

NOTE: PRE-CUT KITS ARE NOT PRE-DRILLED.
 (Holes shown in this drawing are for reference only.
 Drilling of pilot holes are to be done by fabricator.)

THIS DRAWING WAS CREATED AT NO CHARGE TO ASSIST YOU IN VISUALIZING OUR PROPOSAL. THE DRAWING HEREIN IS THE PROPERTY OF SIGNCOMP. PERMISSION TO COPY OR REVISE THIS DRAWING OR TO USE THIS DRAWING FOR PRODUCTION IS STRICTLY PROHIBITED AND CAN ONLY BE COPIED, REVISED OR USED FOR PRODUCTION WITH THE EXPRESSED WRITTEN PERMISSION OF SIGNCOMP.

DRAWN	3/15/2010	SignComp	
CHECKED			
QA		TITLE	
MFG		Series 2 Bleed Body - Series 2/3 Reveal - Assembly	
APPROVED		SIZE	DWG NO
		C	K1120-00
		SCALE	REV
		SHEET 1 OF 1	

Ship To:
 Order #:

Parts List			
ITEM	PART #	DESCRIPTION	NOTES
1	1120	Series 2, 2" Bleed Body	Top & Bottom
2	1120	Series 2, 2" Bleed Body	Sides
3	5331	Series 2 Bleed Body Corner Angle	

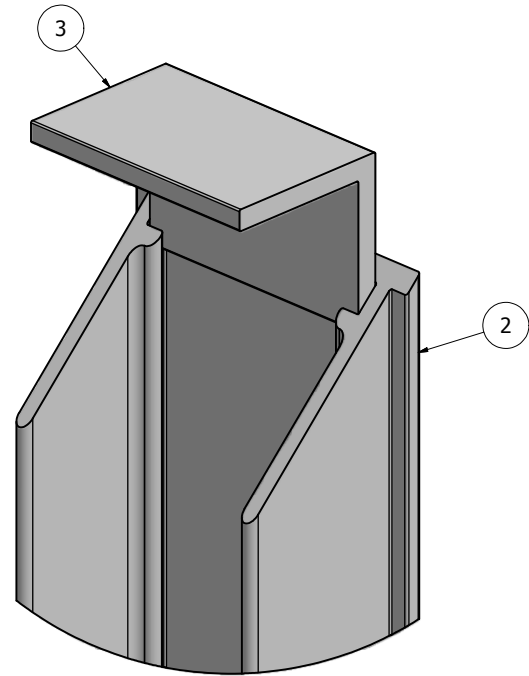
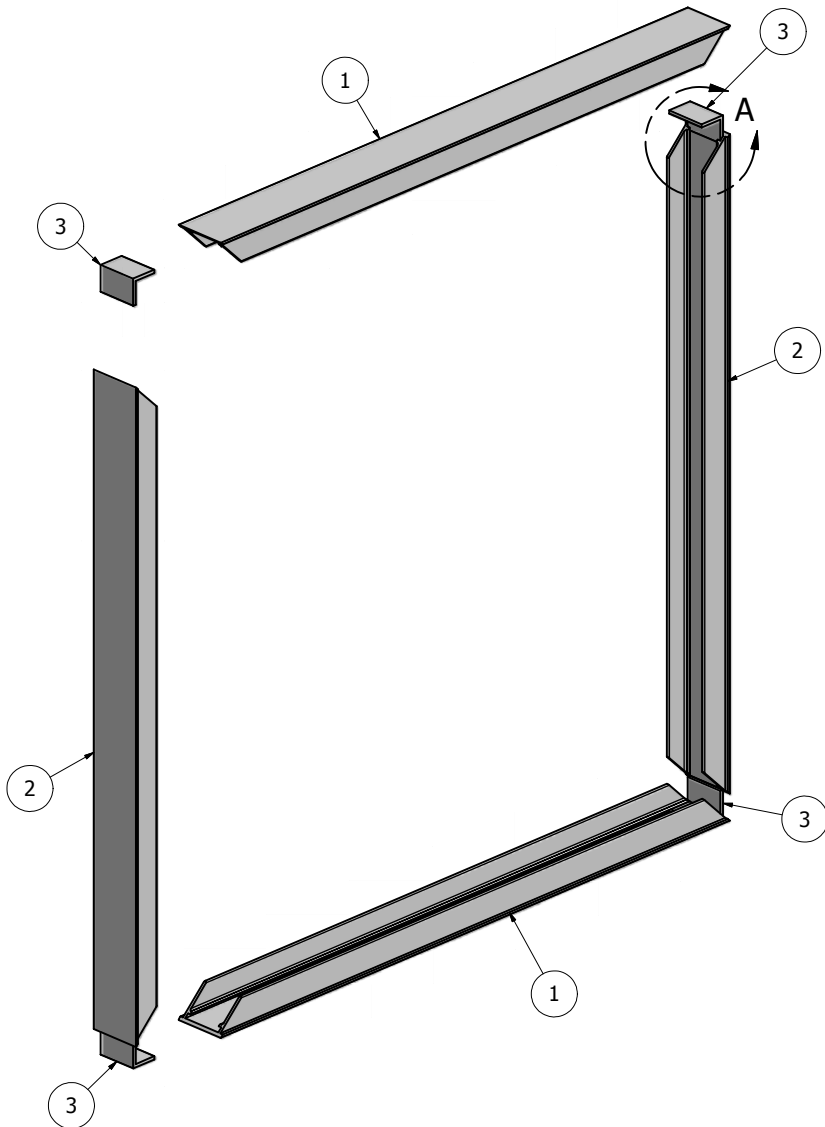

DETAIL A

NOTE: PRE-CUT KITS ARE NOT PRE-DRILLED.
 (Holes shown in this drawing are for reference only.
 Drilling of pilot holes are to be done by fabricator.)

THIS DRAWING WAS CREATED AT NO CHARGE TO ASSIST YOU IN VISUALIZING OUR PROPOSAL. THE DRAWING HEREIN IS THE PROPERTY OF SIGNCOMP. PERMISSION TO COPY OR REVISE THIS DRAWING OR TO USE THIS DRAWING FOR PRODUCTION IS STRICTLY PROHIBITED AND CAN ONLY BE COPIED, REVISED OR USED FOR PRODUCTION WITH THE EXPRESSED WRITTEN PERMISSION OF SIGNCOMP.

DRAWN	1/21/2010	<h1>SignComp</h1> <p>Series 2 Bleed Body Assembly</p>	
CHECKED			
QA			
MFG			
APPROVED			
	SIZE	DWG NO	REV
	C	K1120	
	SCALE	SHEET 1 OF 1	

Ship To:
 Order #:

Parts List			
ITEM	PART	DESCRIPTION	NOTES
1	1100	Series 2 Square Post	
2	1200	Series 2/3 Reveal (Filler)	Tack weld or mechanically fasten to post

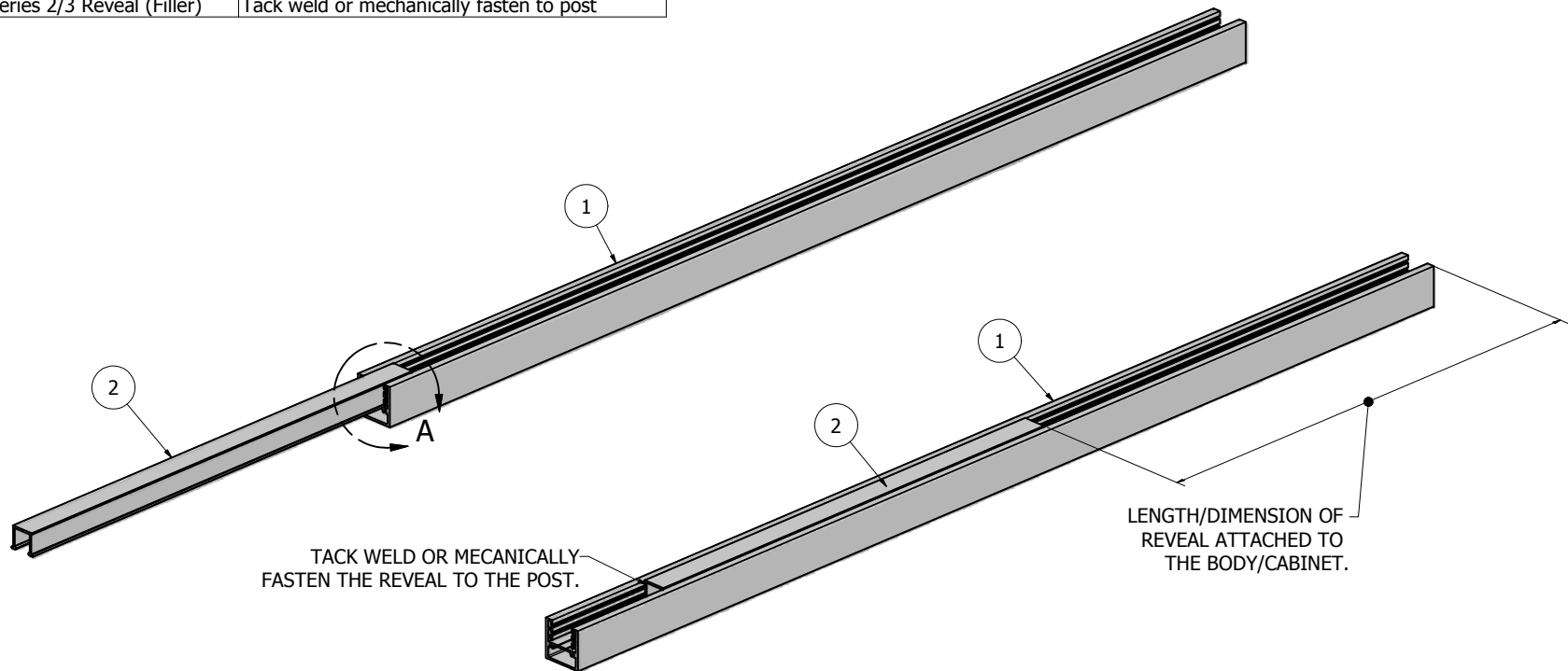

TACK WELD OR MECANICALLY FASTEN THE REVEAL TO THE POST.

LENGTH/DIMENSION OF REVEAL ATTACHED TO THE BODY/CABINET.

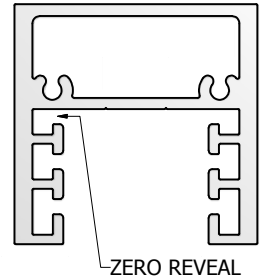

NOTE: PRE-CUT KITS ARE NOT PRE-DRILLED.
 (Holes shown in this drawing are for reference only.
 Drilling of pilot holes are to be done by fabricator.)

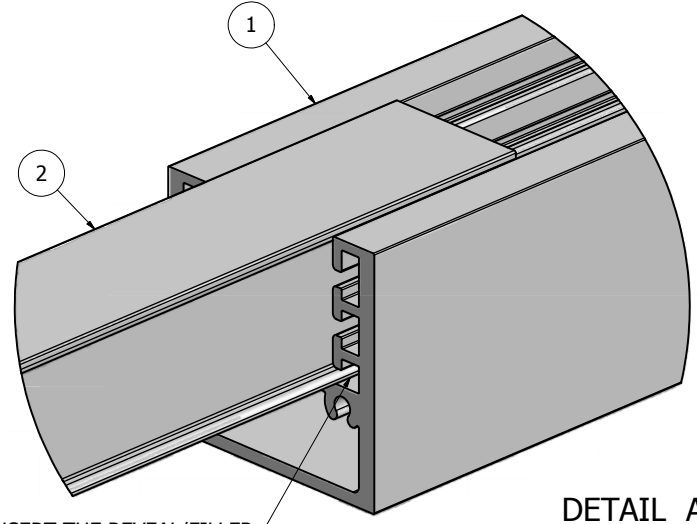

INSERT THE REVEAL/FILLER INTO THE ZERO REVEAL POSTION. SLIDED IT UP INTO THE POST.

DETAIL A

Ship To:
 Order #:

THIS DRAWING WAS CREATED AT NO CHARGE TO ASSIST YOU IN VISUALIZING OUR PROPOSAL. THE DRAWING HEREIN IS THE PROPERTY OF SIGNCOMP. PERMISSION TO COPY OR REVISE THIS DRAWING OR TO USE THIS DRAWING FOR PRODUCTION IS STRICTLY PROHIBITED AND CAN ONLY BE COPIED, REVISED OR USED FOR PRODUCTION WITH THE EXPRESSED WRITTEN PERMISSION OF SIGNCOMP.

DRAWN	3/31/2010	SignComp	
CHECKED			
QA		TITLE	
MFG		Series 2 Square Post - Series 2/3 Reveal Assembly	
APPROVED		SIZE	DWG NO
		C	K1100-00
		SCALE	SHEET 1 OF 1