

PARTS LIST			
ITEM	PART #	DESCRIPTION	NOTES
1	K1928	2Part 9in Double Face Body	Assembly
2	K1960/42	2Part Inner/Outer Frame	Assembly
24	5290	Retainer Screw	Drill 1/8" pilot hole

Ship To:
Sales Order#:

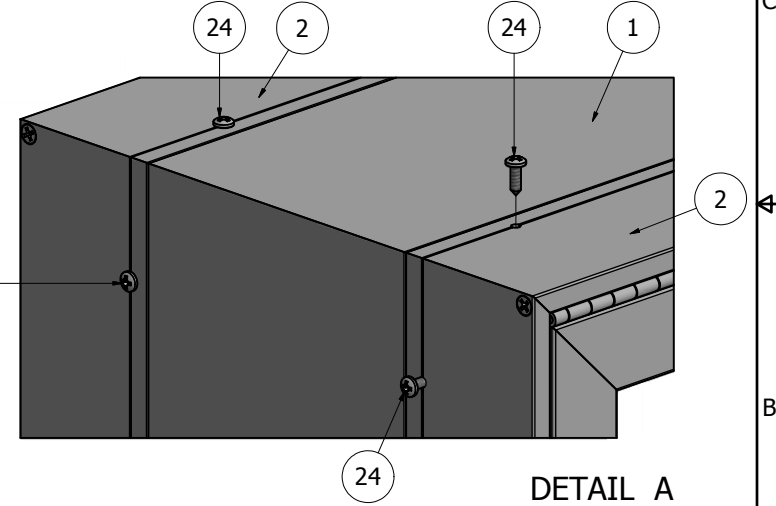
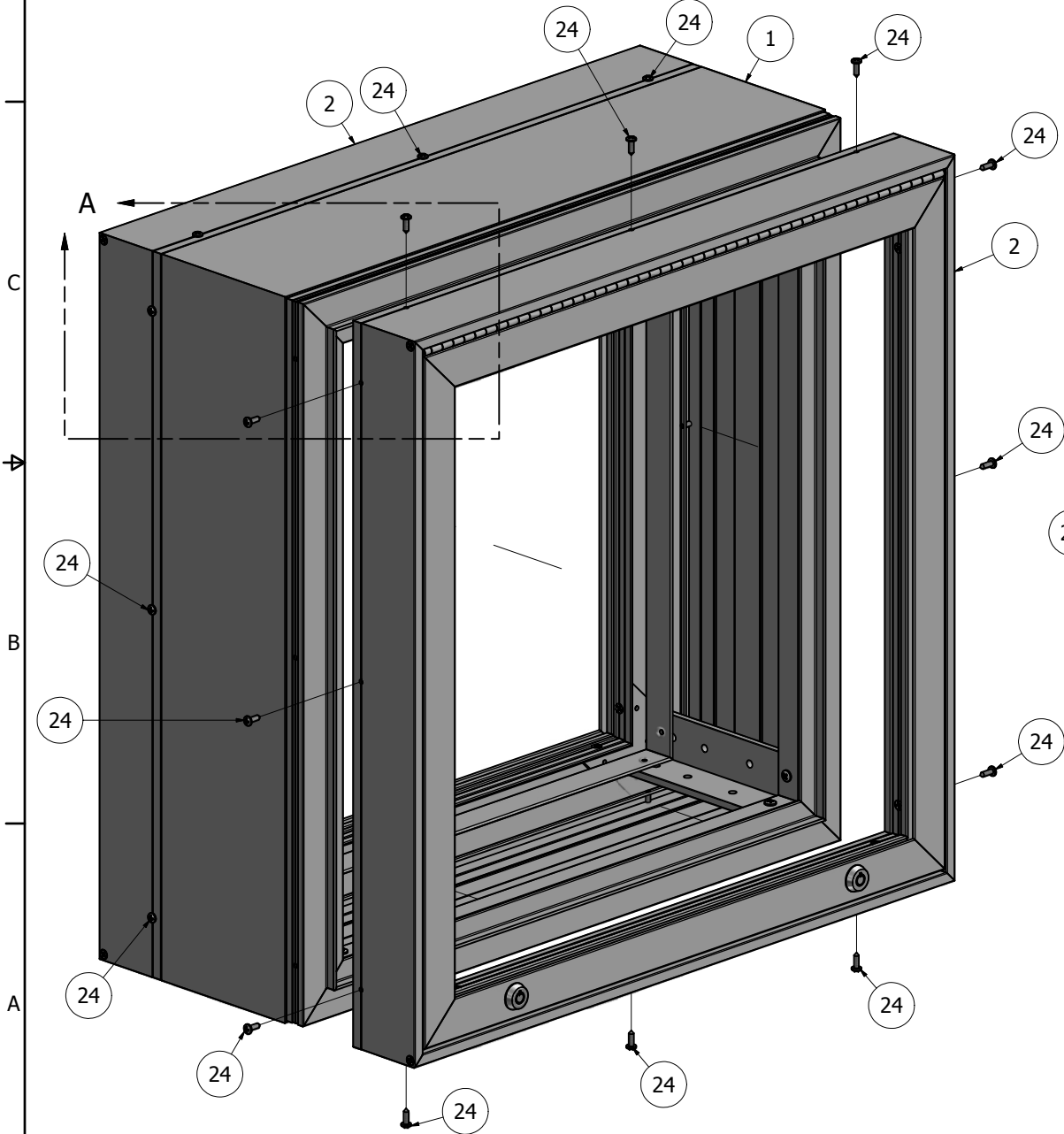
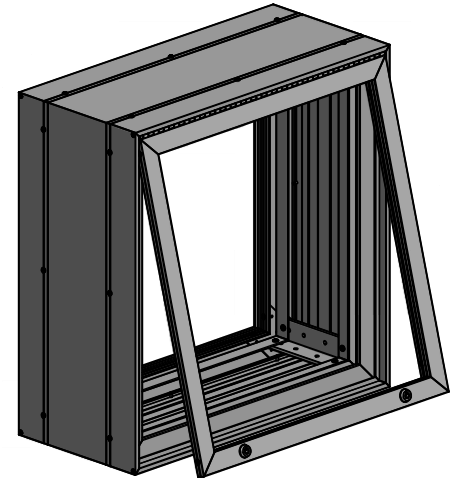
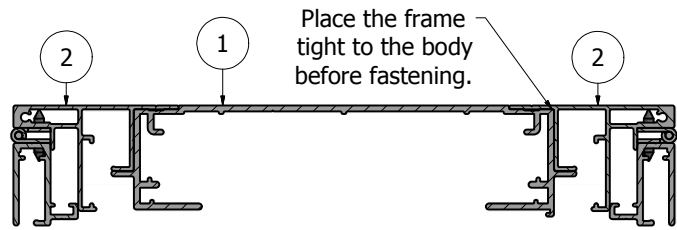

DETAIL A

NOTE: PRE-CUT KITS ARE NOT PRE-DRILLED.
(Holes shown in this drawing are for reference only. Drilling of pilot holes are to be done by fabricator.)

THIS DRAWING WAS CREATED AT NO CHARGE TO ASSIST YOU IN VISUALIZING OUR PROPOSAL. THE DRAWING HEREIN IS THE PROPERTY OF SIGNCOMP. PERMISSION TO COPY OR REVISE THIS DRAWING OR TO USE THIS DRAWING FOR PRODUCTION IS STRICTLY PROHIBITED AND CAN ONLY BE COPIED, REVISED OR USED FOR PRODUCTION WITH THE EXPRESSED WRITTEN PERMISSION OF SIGNCOMP.

DRAWN	SBreihof	6/25/2012	SignComp
Centroid X:	0.000 in		
Centroid Y:	0.000 in		TITLE
Principal Moments Ix:	0.000 in ⁴		2 Part 9in Double Face Body w/ Vandal Frame - Assembly
Principal Moments Iy:	0.000 in ⁴		DWG NO
Section Modulus Ix:	0.000 in ³		K1928/60/42
Section Modulus Iy:	0.000 in ³		REV

PARTS LIST			
ITEM	PART#	DESCRIPTION	NOTES
1	1928	2Part 9in Double Face Body	Top & Bottom
2	1928	2Part 9in Double Face Body	Sides
3	5978	1Part 2Part 9in Body Corner Angle	
4	5210	Corner Key	
13	5218	Corner Angle Screw	Drill 5/32" pilot hole

Ship To:
Sales Order#:

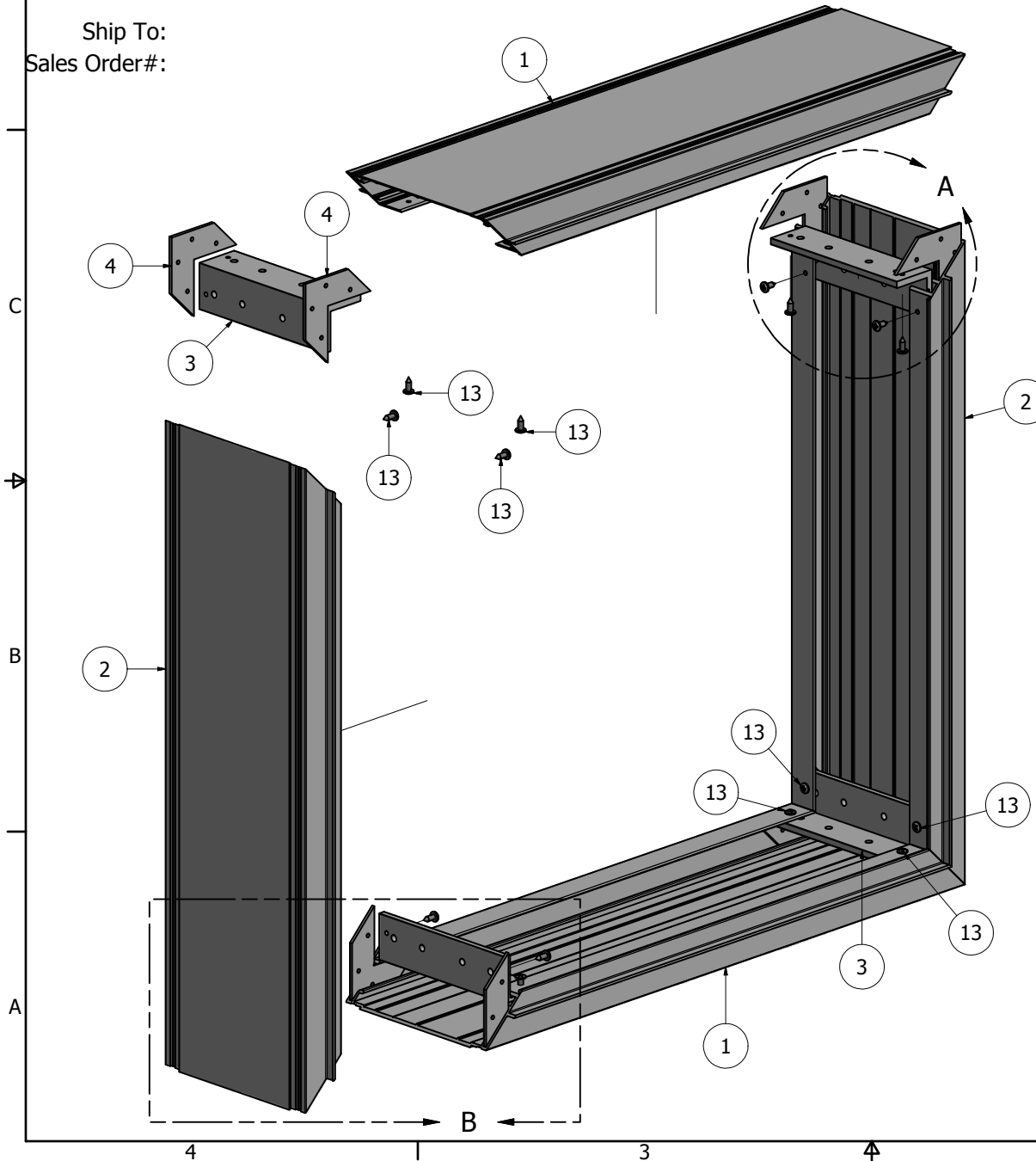

Corner Key floats in the extrusion helping align the mitres while providing additional strength.

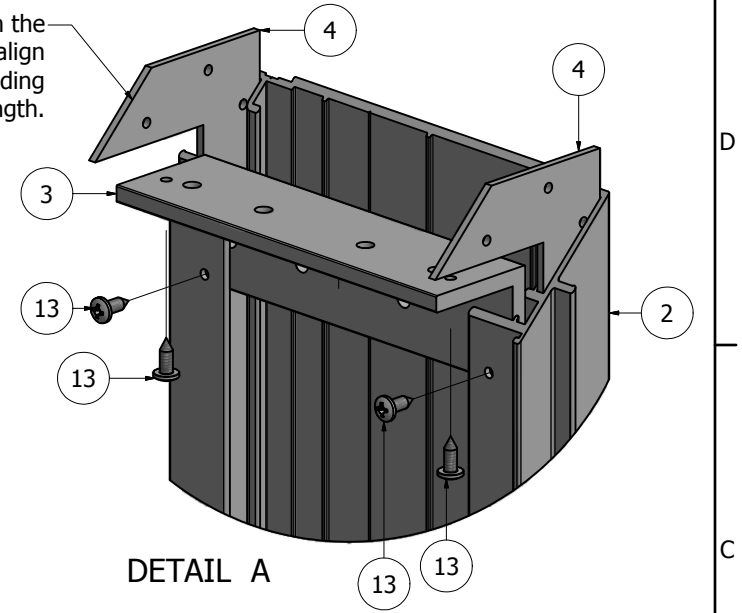

DETAIL A

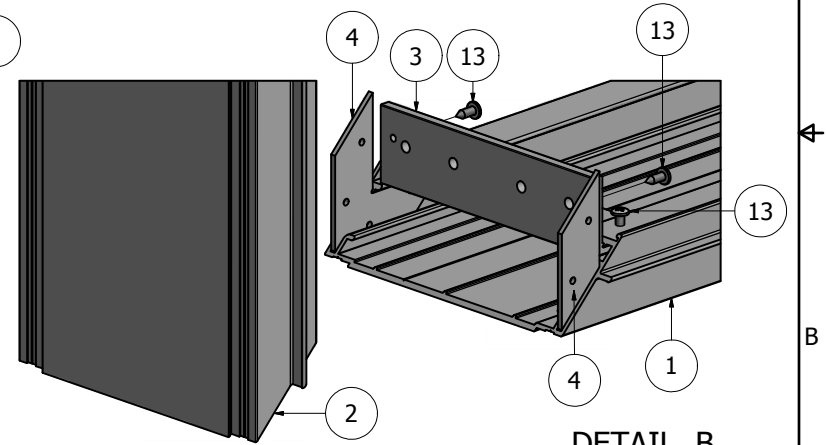

DETAIL B

NOTE: PRE-CUT KITS ARE NOT PRE-DRILLED.

(Holes shown in this drawing are for reference only. Drilling of pilot holes are to be done by fabricator.)

THIS DRAWING WAS CREATED AT NO CHARGE TO ASSIST YOU IN VISUALIZING OUR PROPOSAL. THE DRAWING HEREIN IS THE PROPERTY OF SIGNCOMP. PERMISSION TO COPY OR REVISE THIS DRAWING OR TO USE THIS DRAWING FOR PRODUCTION IS STRICTLY PROHIBITED AND CAN ONLY BE COPIED, REVISED OR USED FOR PRODUCTION WITH THE EXPRESSED WRITTEN PERMISSION OF SIGNCOMP.

DRAWN	SBreihof	6/7/2012
Centroid X:	0.000 in	
Centroid Y:	0.000 in	
Principal Moments Ix:	0.000 in ⁴	
Principal Moments Iy:	0.000 in ⁴	
Section Modulus Ix:	0.000 in ³	
Section Modulus Iy:	0.000 in ³	

SignComp

TITLE
2Part 9in Double Face Body - Assembly

DWG NO

K1928

REV

Parts List			
ITEM	PART #	DESCRIPTION	NOTES
1	1960	2Part Inner Frame	Top & Bottom
2	1960	2Part Inner Frame	Ends
3	5210	Corner Key	
23	5241	2Part Inner Frame Corner Screw	Drill #8 Counter Sink

Ship To:

Order Number:

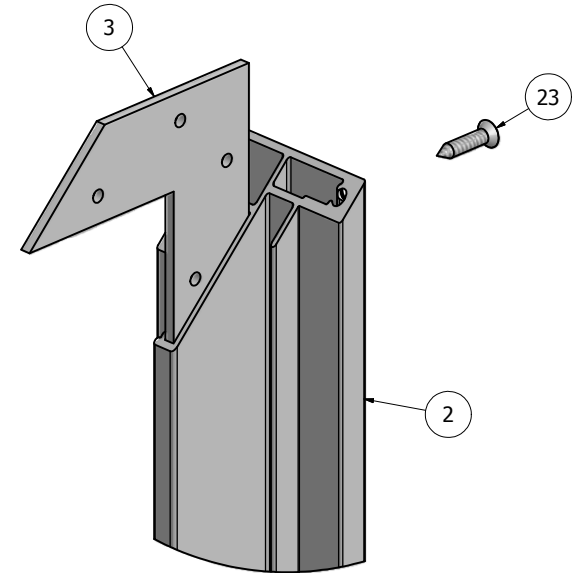
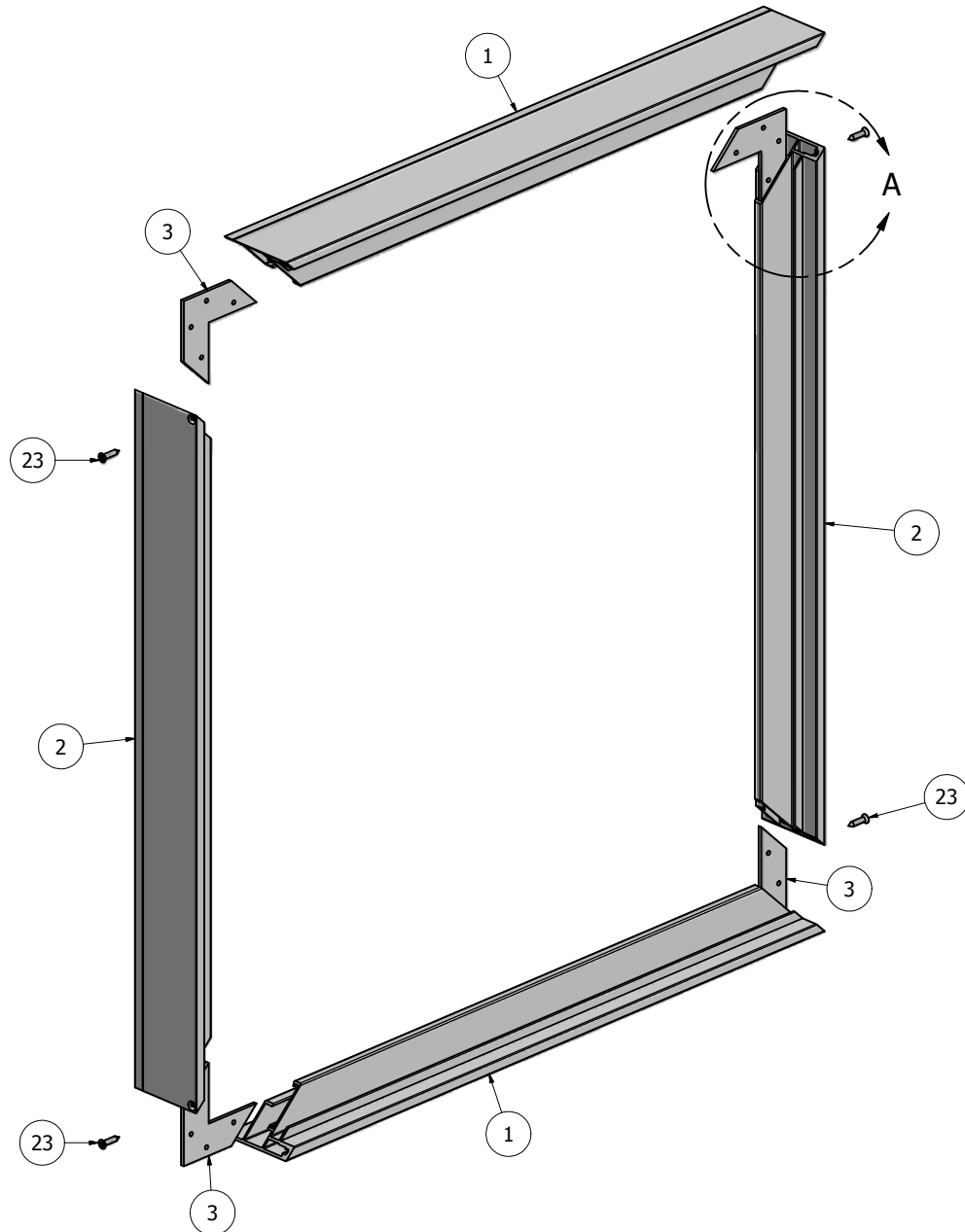

DETAIL A

NOTE: PRE-CUT KITS ARE NOT PRE-DRILLED.

(Holes shown in this drawing are for reference only.
Drilling of pilot holes are to be done by fabricator.)

THIS DRAWING WAS CREATED AT NO CHARGE TO ASSIST YOU IN VISUALIZING OUR PROPOSAL. THE DRAWING HEREIN IS THE PROPERTY OF SIGNCOMP. PERMISSION TO COPY OR REVISE THIS DRAWING OR TO USE THIS DRAWING FOR PRODUCTION IS STRICTLY PROHIBITED AND CAN ONLY BE COPIED, REVISED OR USED FOR PRODUCTION WITH THE EXPRESSED WRITTEN PERMISSION OF SIGNCOMP.

DRAWN	6/17/2010	SignComp	
CHECKED			
QA		TITLE	
MFG		2Part Inner Frame - Assembly	
APPROVED		SIZE	DWG NO
		C	1960
		SCALE	SHEET 1 OF 1

Parts List			
ITEM	PART #	DESCRIPTION	NOTES
1	1942	2Part Outer Frame	Top & Bottom
2	1942	2Part Outer Frame	Ends
3	5975	2Part Outer Frame Corner Angle	
30	5990	2Part Outer Frame Corner Angle Screw	Drill #8 Counter Sink

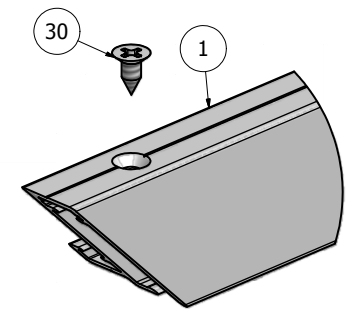
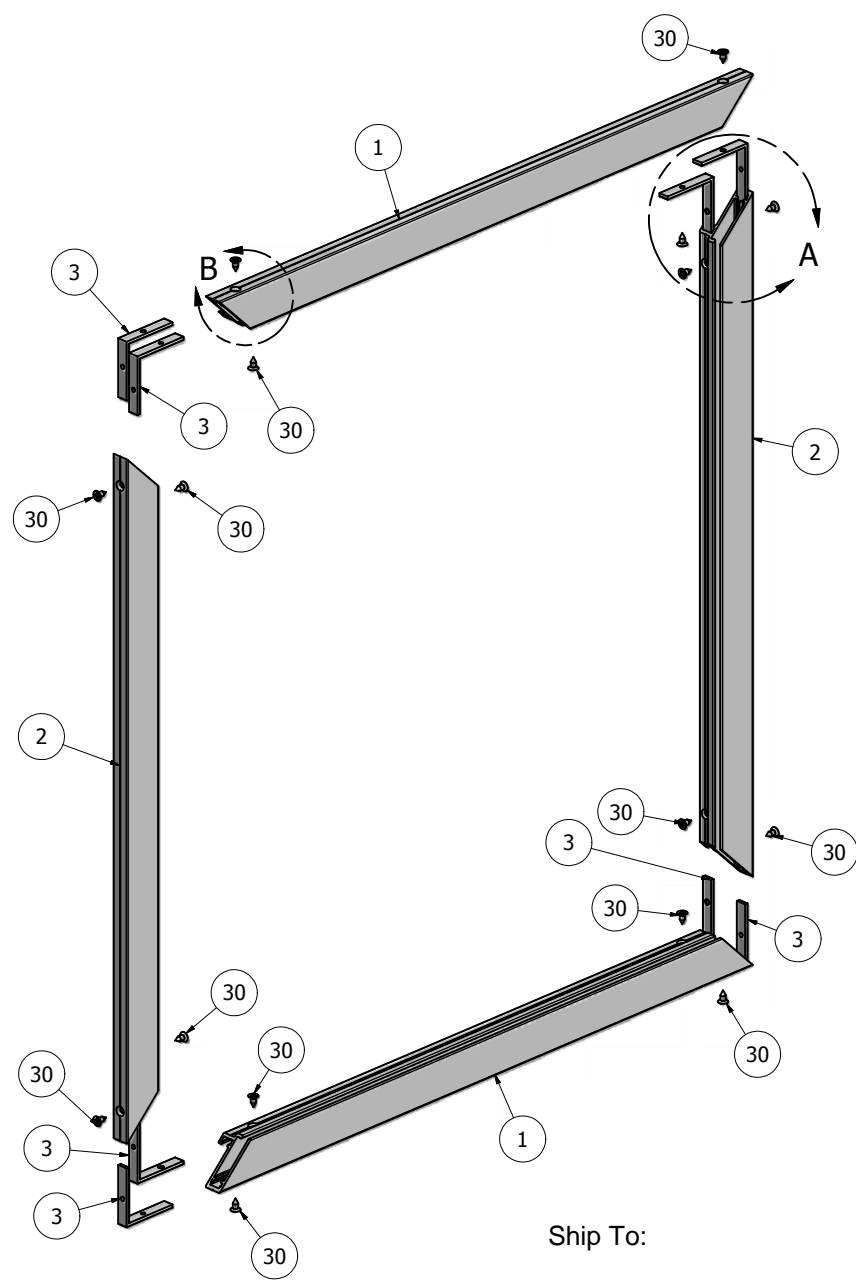

DETAIL B

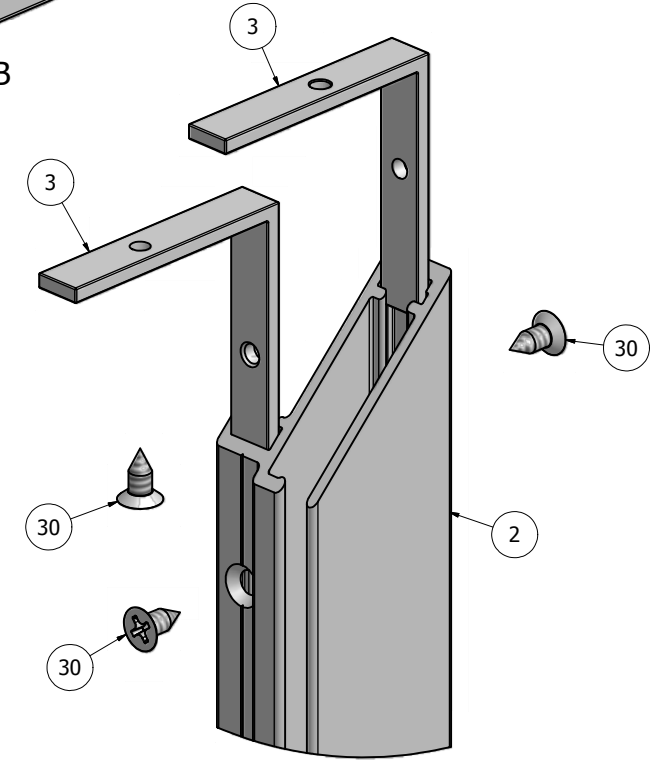

DETAIL A

NOTE: PRE-CUT KITS ARE NOT PRE-DRILLED.
 (Holes shown in this drawing are for reference only.
 Drilling of pilot holes are to be done by fabricator.)

Ship To:
 Order Number:

THIS DRAWING WAS CREATED AT NO CHARGE TO ASSIST YOU IN VISUALIZING OUR PROPOSAL. THE DRAWING HEREIN IS THE PROPERTY OF SIGNCOMP. PERMISSION TO COPY OR REVISE THIS DRAWING OR TO USE THIS DRAWING FOR PRODUCTION IS STRICTLY PROHIBITED AND CAN ONLY BE COPIED, REVISED OR USED FOR PRODUCTION WITH THE EXPRESSED WRITTEN PERMISSION OF SIGNCOMP.			
DRAWN	6/17/2010	SignComp 2Part Outer Frame	
CHECKED			
QA			
MFG			
APPROVED			
SIZE	C	DWG NO	1942
SCALE			REV
			SHEET 1 OF 1

Parts List			
ITEM	PART #	DESCRIPTION	NOTES
1	1942	2Part Outer Frame	
2		Hinge Fastener	1/8" Pop Rivet or #8 Counter Sunk Screw
3	5996	2Part Hinge	
4	5994	2Part Lock	Drill 3/4" Hole - See Detail "A"
5		Lock Nut	
6		Lock Washer	
7		Cam	
8		Cam Nut	

Ship To:
Order Number:

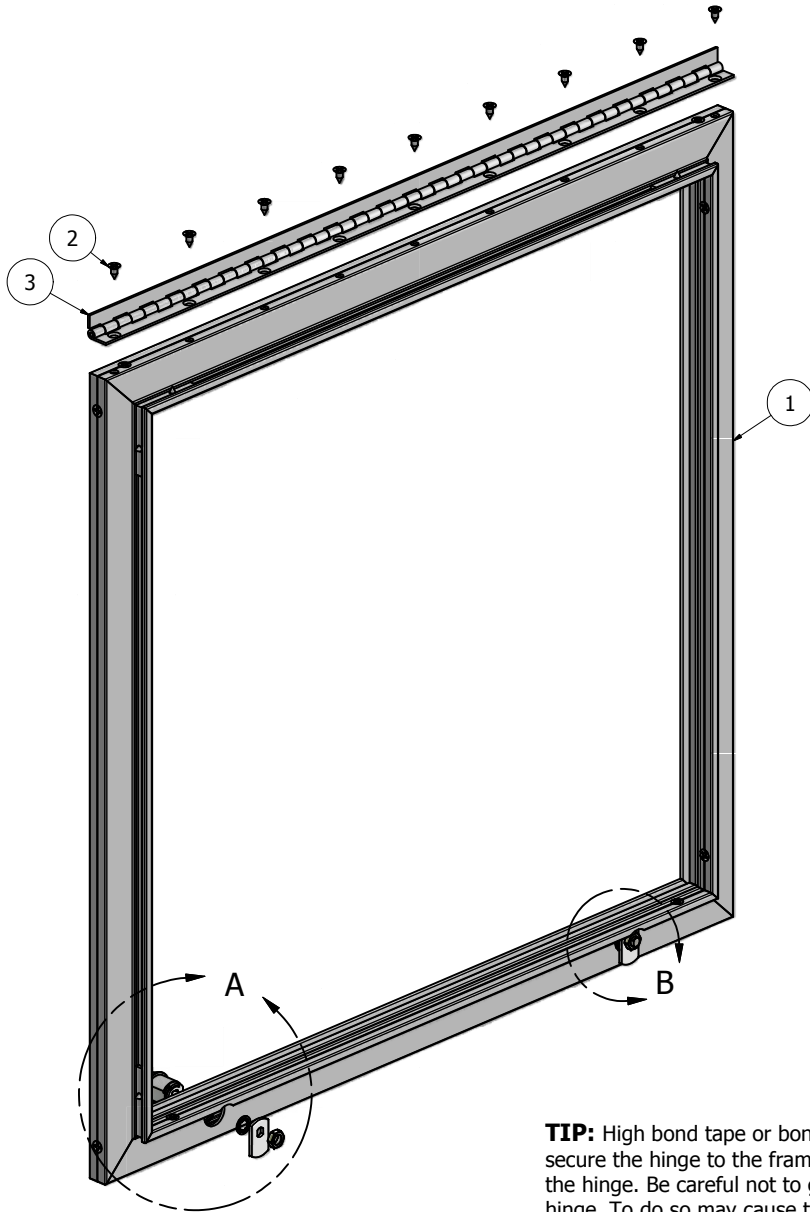

TIP: High bond tape or bonding agents can be used to help secure the hinge to the frame and assist in the installation of the hinge. Be careful not to get the tape on the barrel of the hinge. To do so may cause the hinge not to open properly.

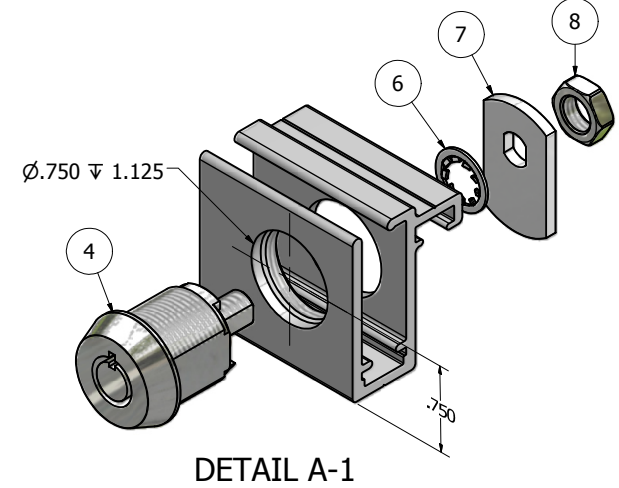

DETAIL A-1

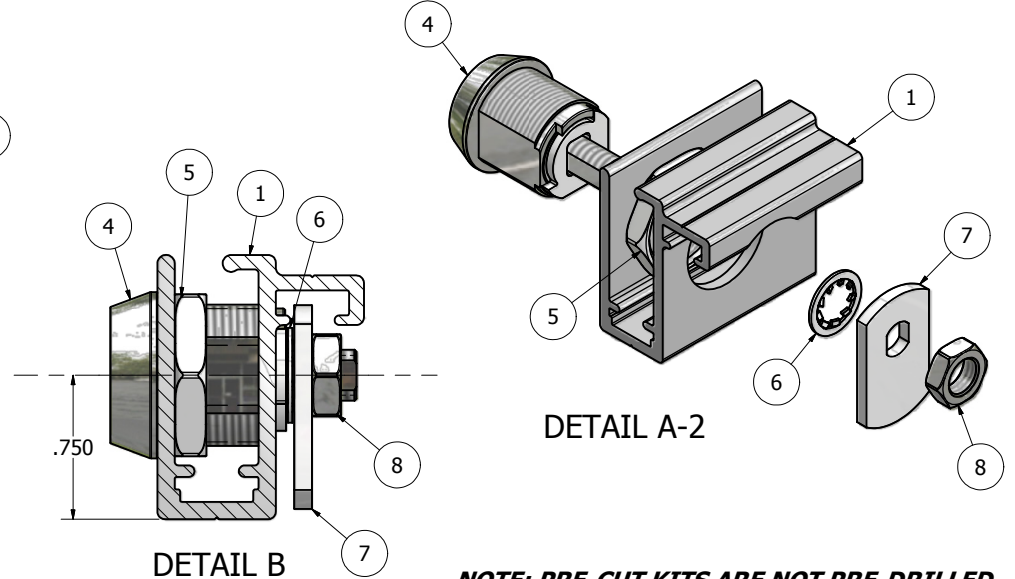

DETAIL A-2

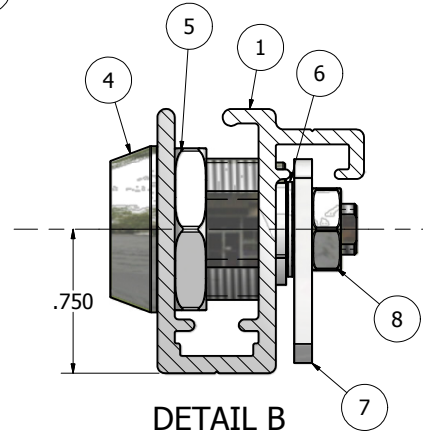

DETAIL B

NOTE: PRE-CUT KITS ARE NOT PRE-DRILLED.
(Holes shown in this drawing are for reference only.
Drilling of pilot holes are to be done by fabricator.)

THIS DRAWING WAS CREATED AT NO CHARGE TO ASSIST YOU IN VISUALIZING OUR PROPOSAL. THE DRAWING HEREIN IS THE PROPERTY OF SIGNCOMP. PERMISSION TO COPY OR REVISE THIS DRAWING OR TO USE THIS DRAWING FOR PRODUCTION IS STRICTLY PROHIBITED AND CAN ONLY BE COPIED, REVISED OR USED FOR PRODUCTION WITH THE EXPRESSED WRITTEN PERMISSION OF SIGNCOMP.

DRAWN	6/17/2010	SignComp	
CHECKED			
QA		TITLE	
MFG		2Part Outer Frame - 2Part Hinge - 2Part Lock - Assembly	
APPROVED		SIZE	DWG NO
		C	1942-5994-96
		SCALE	REV

Parts List			
ITEM	PART #	DESCRIPTION	NOTES
1	K1960	2Part Inner Fame	Assembly
2	K1942	2Part Outer Frame	Assembly
3		Hinge Fastener	1/8" Pop Rivet or #8 Counter Sunk Fastener

Ship To:

Order Number:

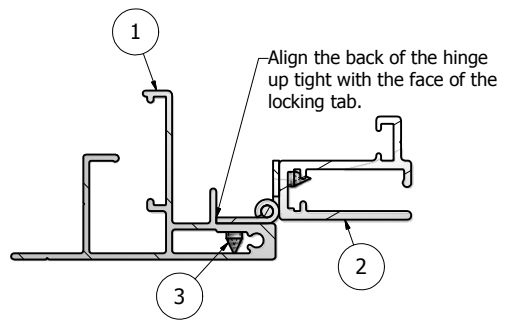
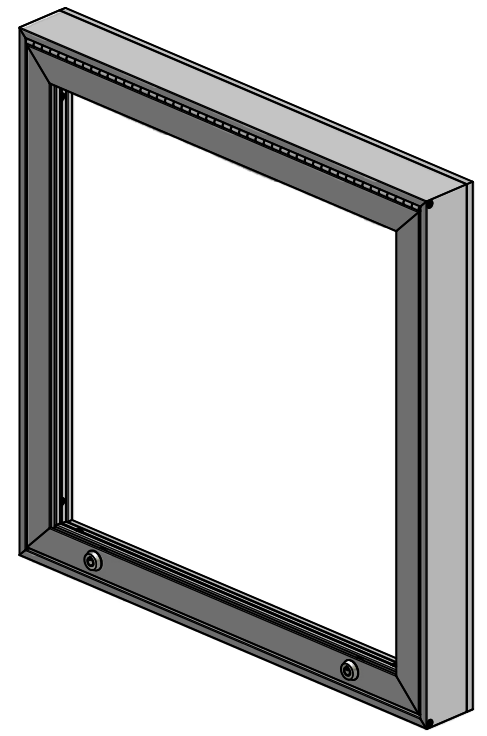
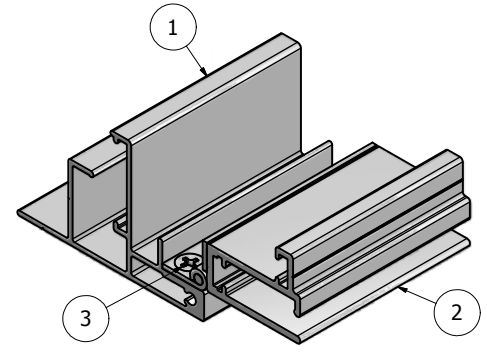
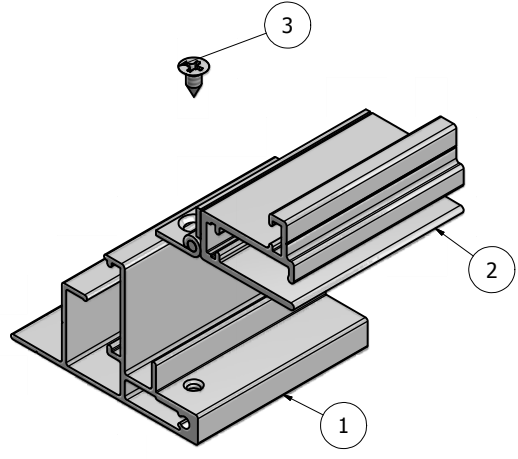
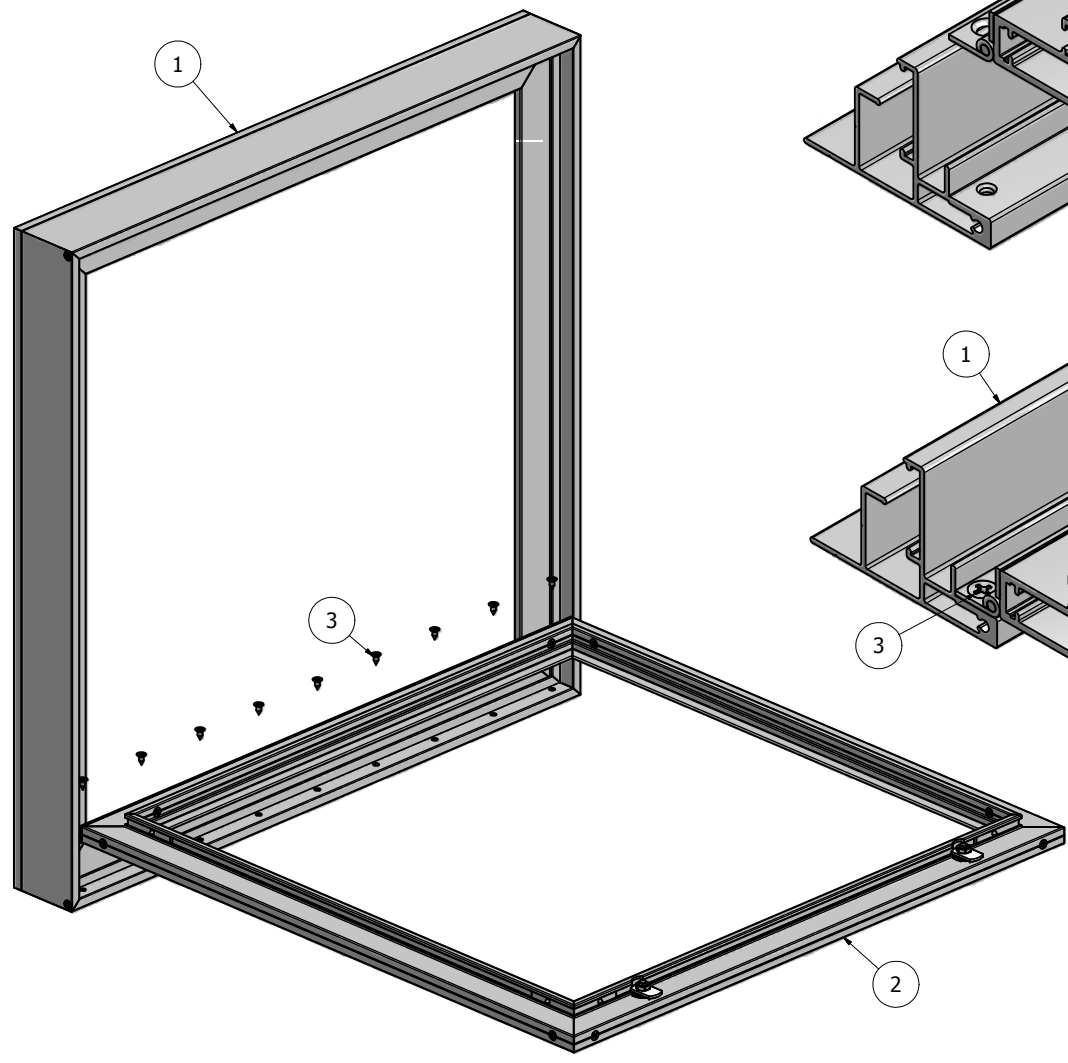

NOTE: PRE-CUT KITS ARE NOT PRE-DRILLED.
 (Holes shown in this drawing are for reference only.
 Drilling of pilot holes are to be done by fabricator.)

TIP: High bond tape or bonding agents can be used to help secure the hinge to the frame and assist in the installation of the hinge. Be careful not to get the tape on the barrel of the hinge. To do so may cause the hinge not to open properly.

THIS DRAWING WAS CREATED AT NO CHARGE TO ASSIST YOU IN VISUALIZING OUR PROPOSAL. THE DRAWING HEREIN IS THE PROPERTY OF SIGNCOMP. PERMISSION TO COPY OR REVISE THIS DRAWING OR TO USE THIS DRAWING FOR PRODUCTION IS STRICTLY PROHIBITED AND CAN ONLY BE COPIED, REVISED OR USED FOR PRODUCTION WITH THE EXPRESSED WRITTEN PERMISSION OF SIGNCOMP.

DRAWN	Steve	6/18/2010	SignComp		
CHECKED					
QA			TITLE		
MFG			2Part Inner Frame - 2Part Outer Frame - Assembly		
APPROVED			SIZE	DWG NO	REV
			C	1960-42	
			SCALE	SHEET 1 OF 1	