

PARTS LIST			
ITEM	PART#	DESCRIPTION	NOTES
1	K1926	2Part 6in Single Face Body	Assembly
2	K1959/41	2Part Large Inner / Outer Frame	Assembly
24	5290	Retainer Screw	Drill 1/8" pilot hole

Ship To:
Sales Order#:

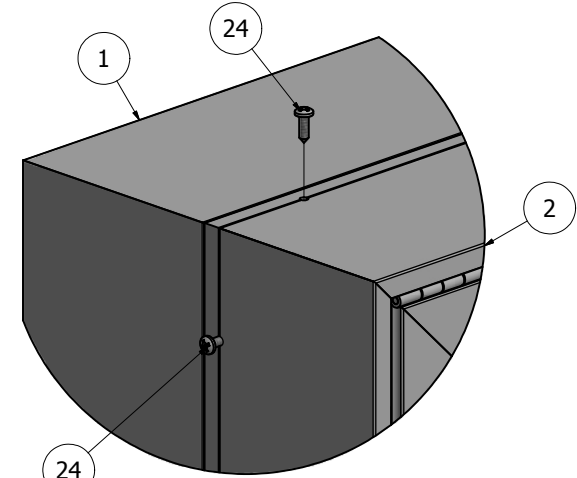
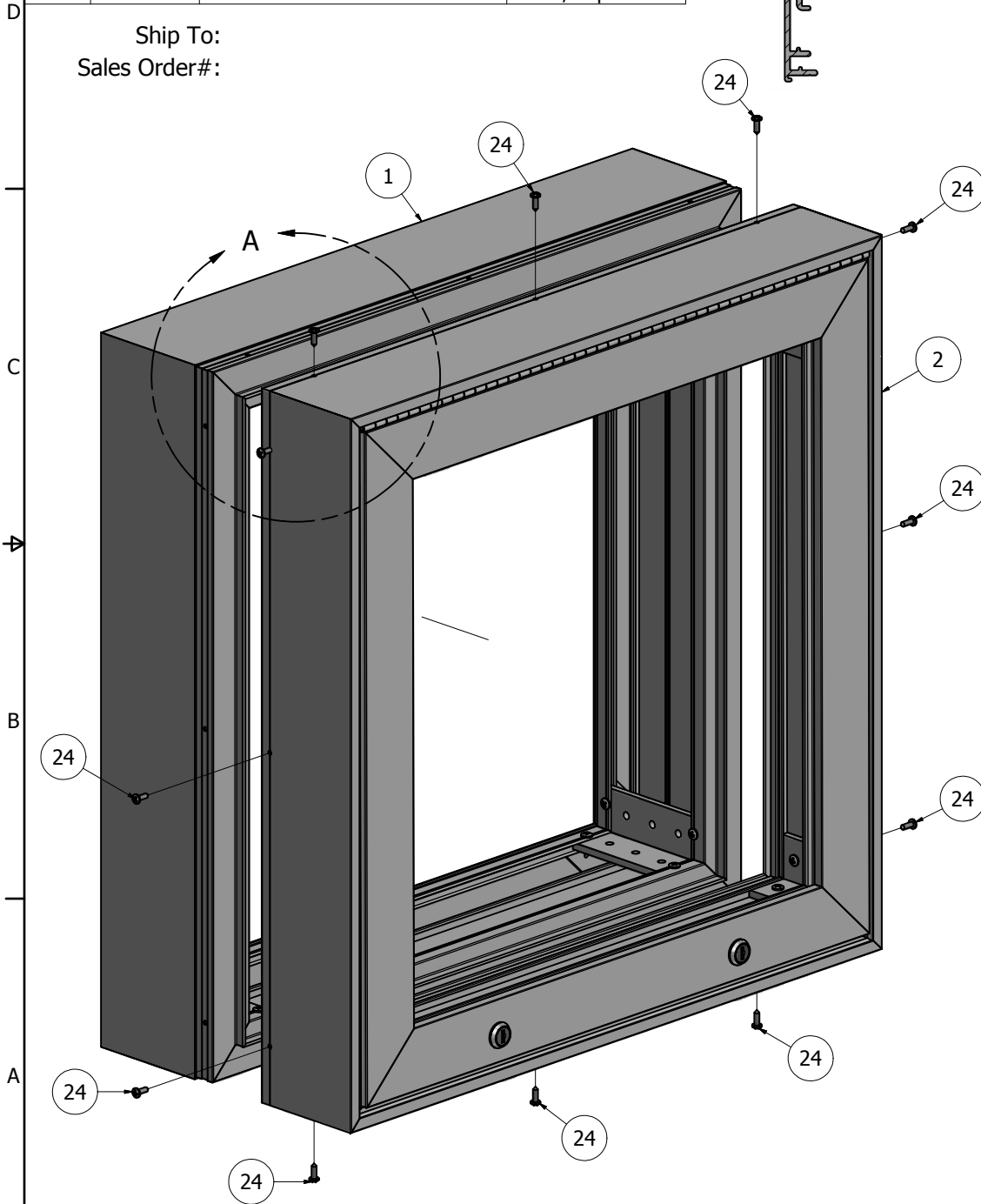
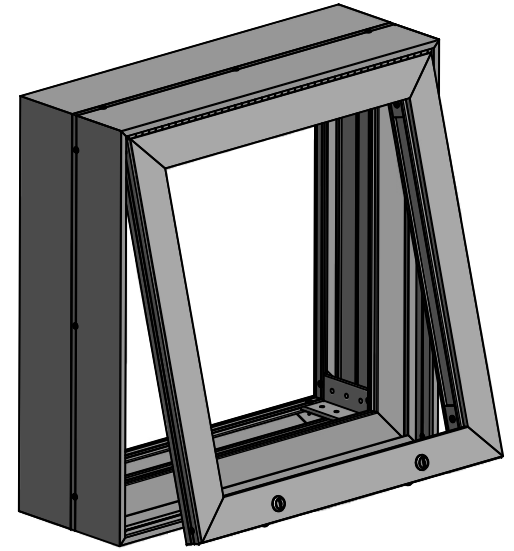
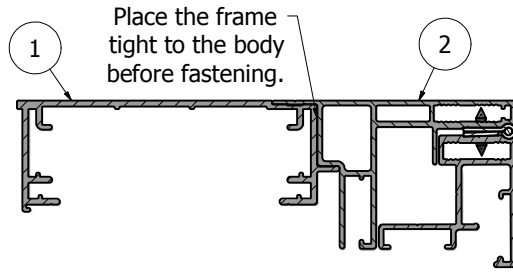

DETAIL A

NOTE: PRE-CUT KITS ARE NOT PRE-DRILLED.
(Holes shown in this drawing are for reference only.
Drilling of pilot holes are to be done by fabricator.)

THIS DRAWING WAS CREATED AT NO CHARGE TO ASSIST YOU IN VISUALIZING OUR PROPOSAL. THE DRAWING HEREIN IS THE PROPERTY OF SIGNCOMP. PERMISSION TO COPY OR REVISE THIS DRAWING OR TO USE THIS DRAWING FOR PRODUCTION IS STRICTLY PROHIBITED AND CAN ONLY BE COPIED, REVISED OR USED FOR PRODUCTION WITH THE EXPRESSED WRITTEN PERMISSION OF SIGNCOMP.

DRAWN	SBreihof	6/7/2012	<h1>SignComp</h1>
Centroid X:	0.000 in		
Centroid Y:	0.000 in		TITLE
Principal Moments Ix:	0.000 in ⁴		2Part 6in Single Face Body w/ Large Vandal Frame - Assembly
Principal Moments Iy:	0.000 in ⁴		DWG NO
Section Modulus Ix:	0.000 in ³		K1926/59/41
Section Modulus Iy:	0.000 in ³		REV

PARTS LIST			
ITEM	PART #	DESCRIPTION	NOTES
1	1926	2Part 6in Single Face Body	Top & Bottom
2	1926	2Part 6in Single Face Body	Sides
3	5981	1Part 2Part 6in Body Corner Angle	
4	5210	Corner Key	
13	5218	Corner Angle Screw	Drill 5/32" pilot hole

D
C
B
A

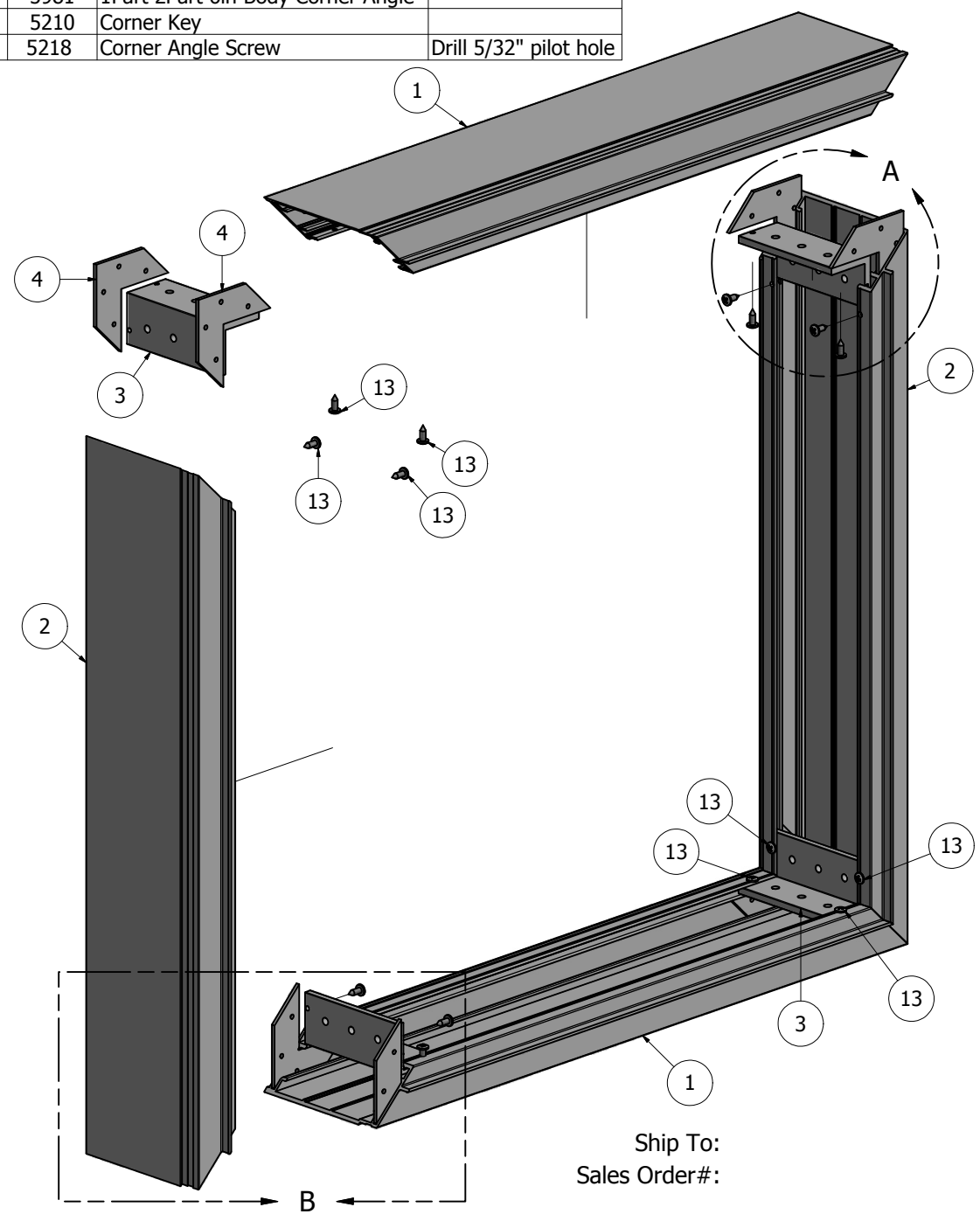

Corner Key floats in the extrusion helping align the mitres while providing additional strength.

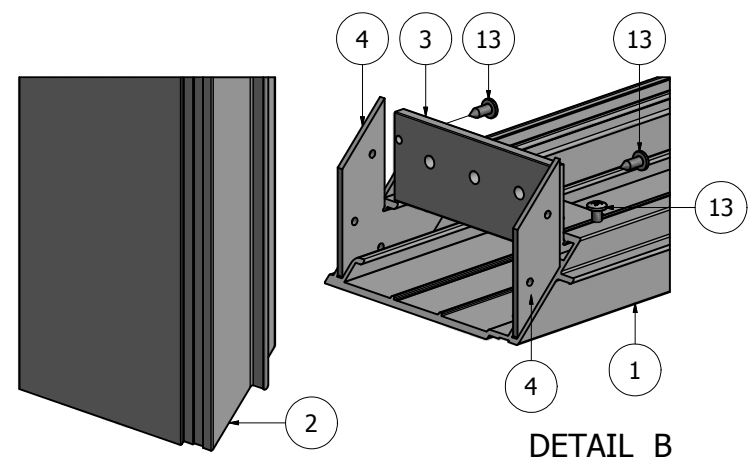
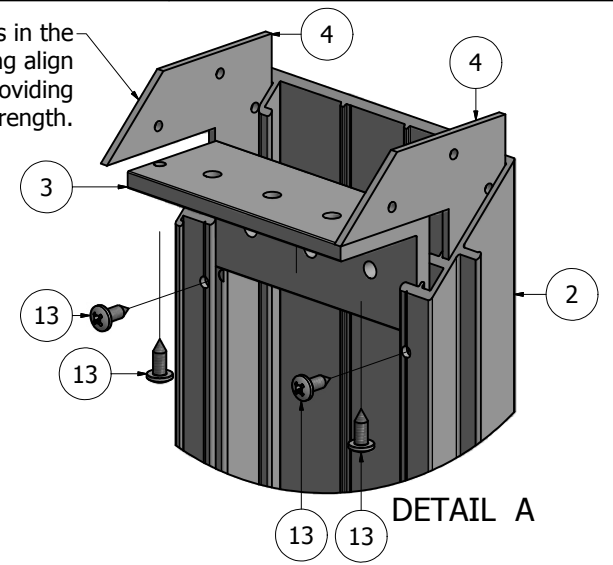

NOTE: PRE-CUT KITS ARE NOT PRE-DRILLED.
(Holes shown in this drawing are for reference only. Drilling of pilot holes are to be done by fabricator.)

THIS DRAWING WAS CREATED AT NO CHARGE TO ASSIST YOU IN VISUALIZING OUR PROPOSAL. THE DRAWING HEREIN IS THE PROPERTY OF SIGNCOMP. PERMISSION TO COPY OR REVISE THIS DRAWING OR TO USE THIS DRAWING FOR PRODUCTION IS STRICTLY PROHIBITED AND CAN ONLY BE COPIED, REVISED OR USED FOR PRODUCTION WITH THE EXPRESSED WRITTEN PERMISSION OF SIGNCOMP.

DRAWN	SBreihof	6/7/2012	SignComp
Centroid X:	0.000 in		
Centroid Y:	0.000 in		TITLE
Principal Moments Ix:	0.000 in ⁴		2Part 6in Single Face Body - Assembly
Principal Moments Iy:	0.000 in ⁴		
Section Modulus Ix:	0.000 in ³		DWG NO
Section Modulus Iy:	0.000 in ³		K1926
			REV

Ship To:
Sales Order#:

PARTS LIST			
ITEM	PART #	DESCRIPTION	NOTES
1	1959	2Part Large Inner Frame	Top & Bottom
2	1959	2Part Large Inner Frame	Sides
3	5210	Corner Key	
4	5305	Frame Corner Angle	
13	5990	Corner Angle Screw	Drill #10 Counter Sink

D
C
B
A

3

2

1

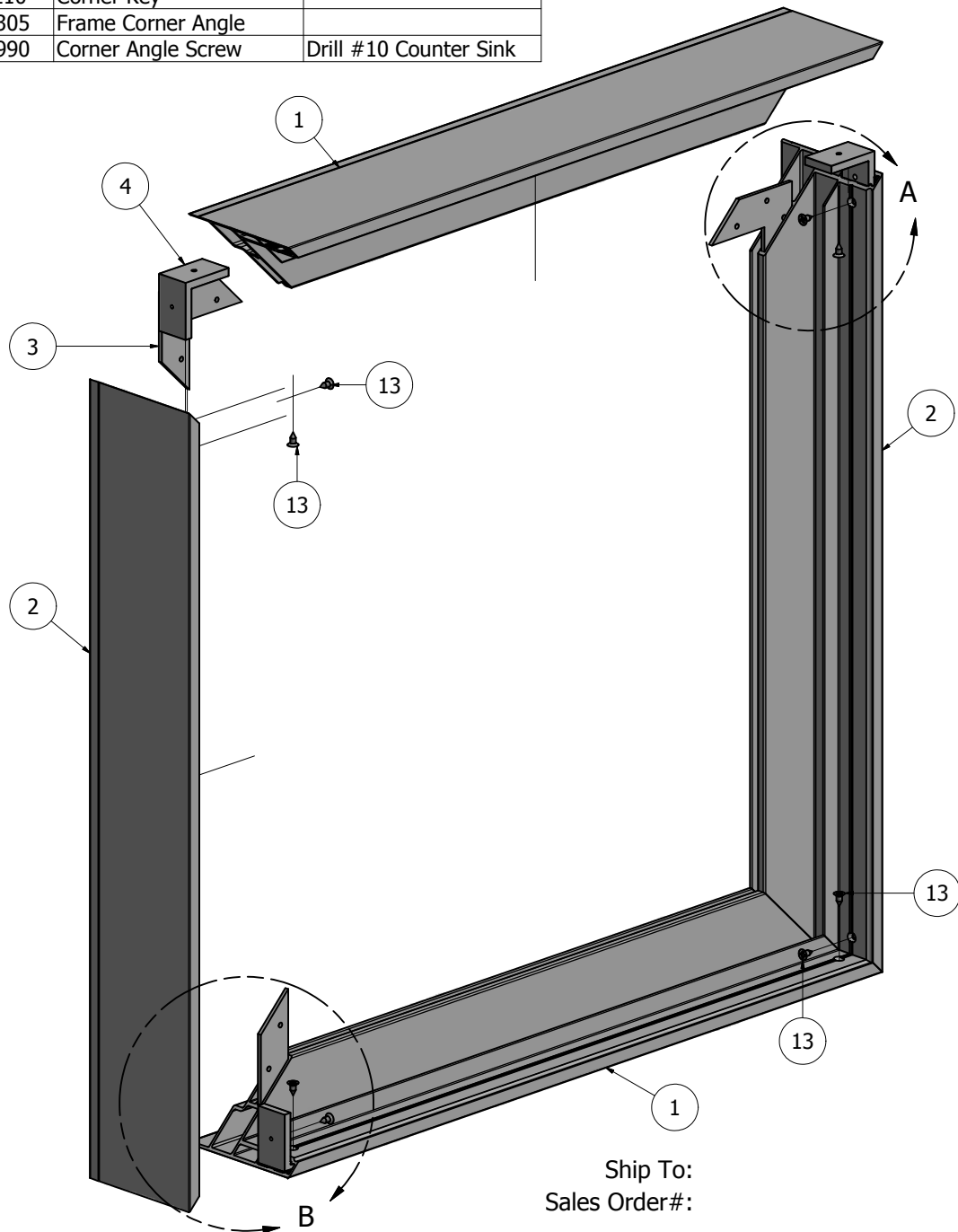

Corner Key floats in the extrusion helping align the mitres while providing additional strength.

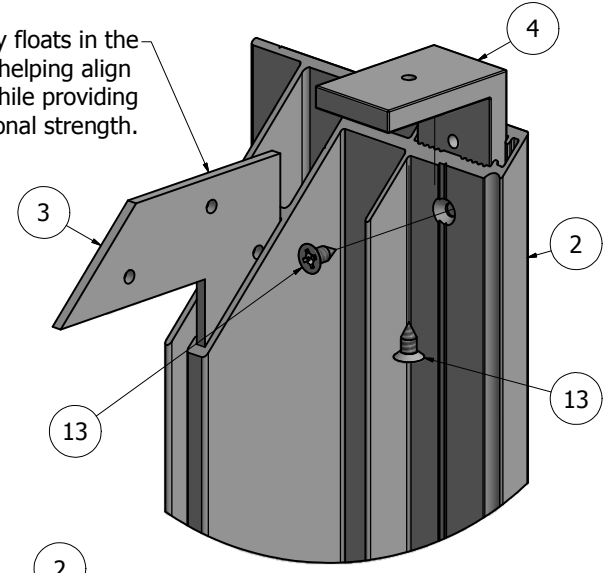

DETAIL A

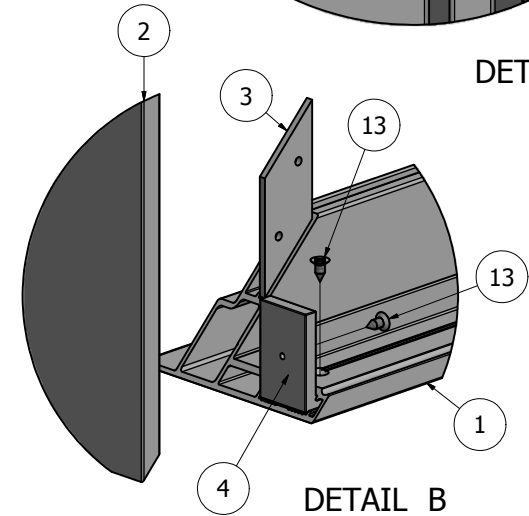

DETAIL B

NOTE: PRE-CUT KITS ARE NOT PRE-DRILLED.
(Holes shown in this drawing are for reference only.
Drilling of pilot holes are to be done by fabricator.)

THIS DRAWING WAS CREATED AT NO CHARGE TO ASSIST YOU IN VISUALIZING OUR PROPOSAL. THE DRAWING HEREIN IS THE PROPERTY OF SIGNCOMP. PERMISSION TO COPY OR REVISE THIS DRAWING OR TO USE THIS DRAWING FOR PRODUCTION IS STRICTLY PROHIBITED AND CAN ONLY BE COPIED, REVISED OR USED FOR PRODUCTION WITH THE EXPRESSED WRITTEN PERMISSION OF SIGNCOMP.

DRAWN	SBreihof	6/6/2012
Centroid X:	0.000 in	
Centroid Y:	0.000 in	
Principal Moments Ix:	0.000 in ⁴	
Principal Moments Iy:	0.000 in ⁴	
Section Modulus Ix:	0.000 in ³	
Section Modulus Iy:	0.000 in ³	

SignComp

TITLE
2Part Lg Inner Frame - Assembly

DWG NO	K1959	REV
--------	--------------	-----

Ship To:
Sales Order#:

4

3

4

2

1

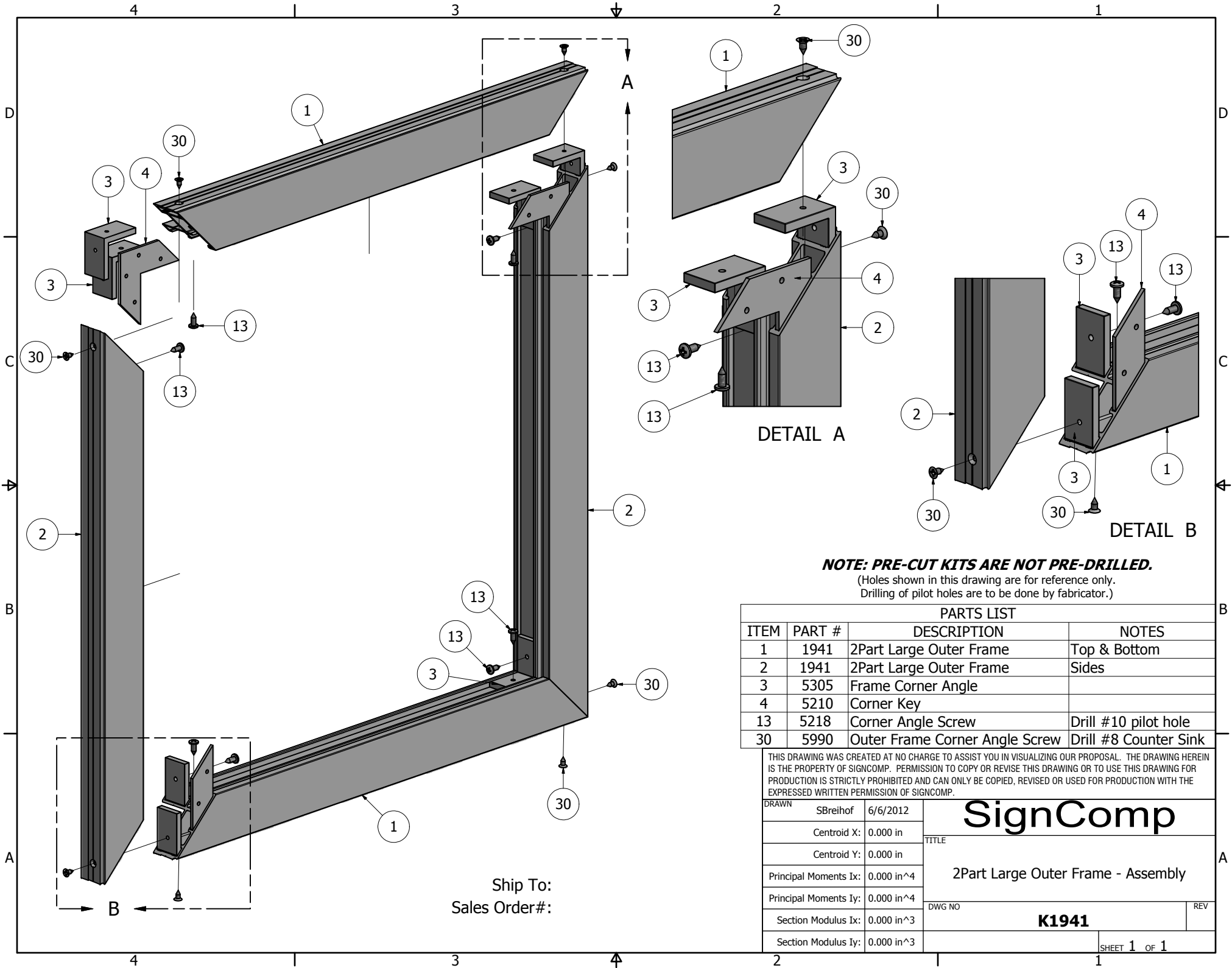

NOTE: PRE-CUT KITS ARE NOT PRE-DRILLED.
 (Holes shown in this drawing are for reference only.
 Drilling of pilot holes are to be done by fabricator.)

PARTS LIST			
ITEM	PART #	DESCRIPTION	NOTES
1	1941	2Part Large Outer Frame	Top & Bottom
2	1941	2Part Large Outer Frame	Sides
3	5305	Frame Corner Angle	
4	5210	Corner Key	
13	5218	Corner Angle Screw	Drill #10 pilot hole
30	5990	Outer Frame Corner Angle Screw	Drill #8 Counter Sink

THIS DRAWING WAS CREATED AT NO CHARGE TO ASSIST YOU IN VISUALIZING OUR PROPOSAL. THE DRAWING HEREIN IS THE PROPERTY OF SIGNCOMP. PERMISSION TO COPY OR REVISE THIS DRAWING OR TO USE THIS DRAWING FOR PRODUCTION IS STRICTLY PROHIBITED AND CAN ONLY BE COPIED, REVISED OR USED FOR PRODUCTION WITH THE EXPRESSED WRITTEN PERMISSION OF SIGNCOMP.

DRAWN	SBreihof	6/6/2012	<h1>SignComp</h1>
Centroid X:	0.000 in		
Centroid Y:	0.000 in		
Principal Moments Ix:	0.000 in ⁴		
Principal Moments Iy:	0.000 in ⁴		
Section Modulus Ix:	0.000 in ³		
Section Modulus Iy:	0.000 in ³		
TITLE			
2Part Large Outer Frame - Assembly			
DWG NO			K1941
			REV

Ship To:
 Sales Order#:

Parts List			
ITEM	PART#	DESCRIPTION	Notes
1	1941	2Part Large Outer Frame	
2		Hinge Fastener	1/8" Pop Rivet or #8 Counter Sink Screw
3	5997	2Part Large Hinge	
4	5993	2Part Large Lock	Drill 3/4" Hole - See Detail "A"
5		Large Lock Nut	
6		Lock Spacer	
7		Large Cam	
8		Sprong Washer	
9		Lock Screw	

Ship To:
Sales Order#:

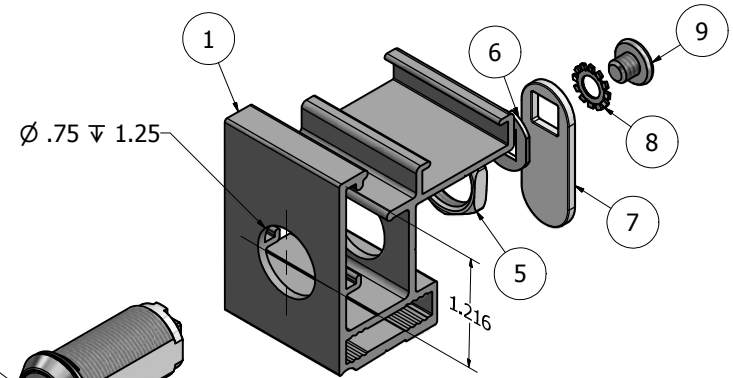

DETAIL A-1

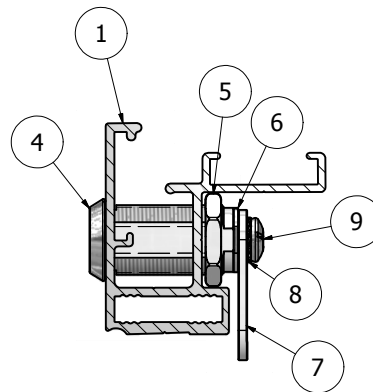
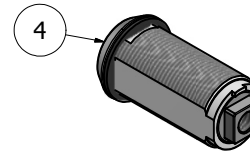
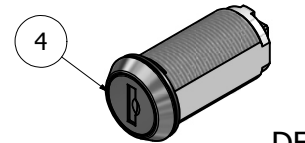

DETAIL B

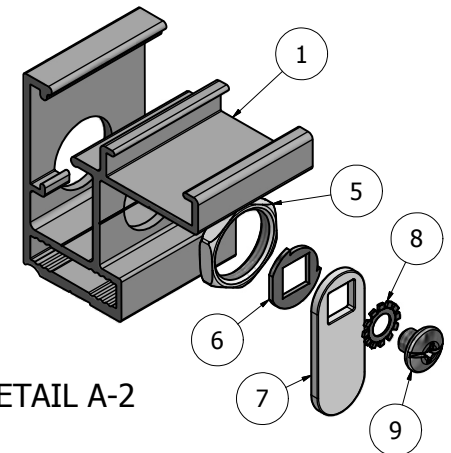

DETAIL A-2

NOTE: PRE-CUT KITS ARE NOT PRE-DRILLED.
(Holes shown in this drawing are for reference only.
Drilling of pilot holes are to be done by fabricator.)

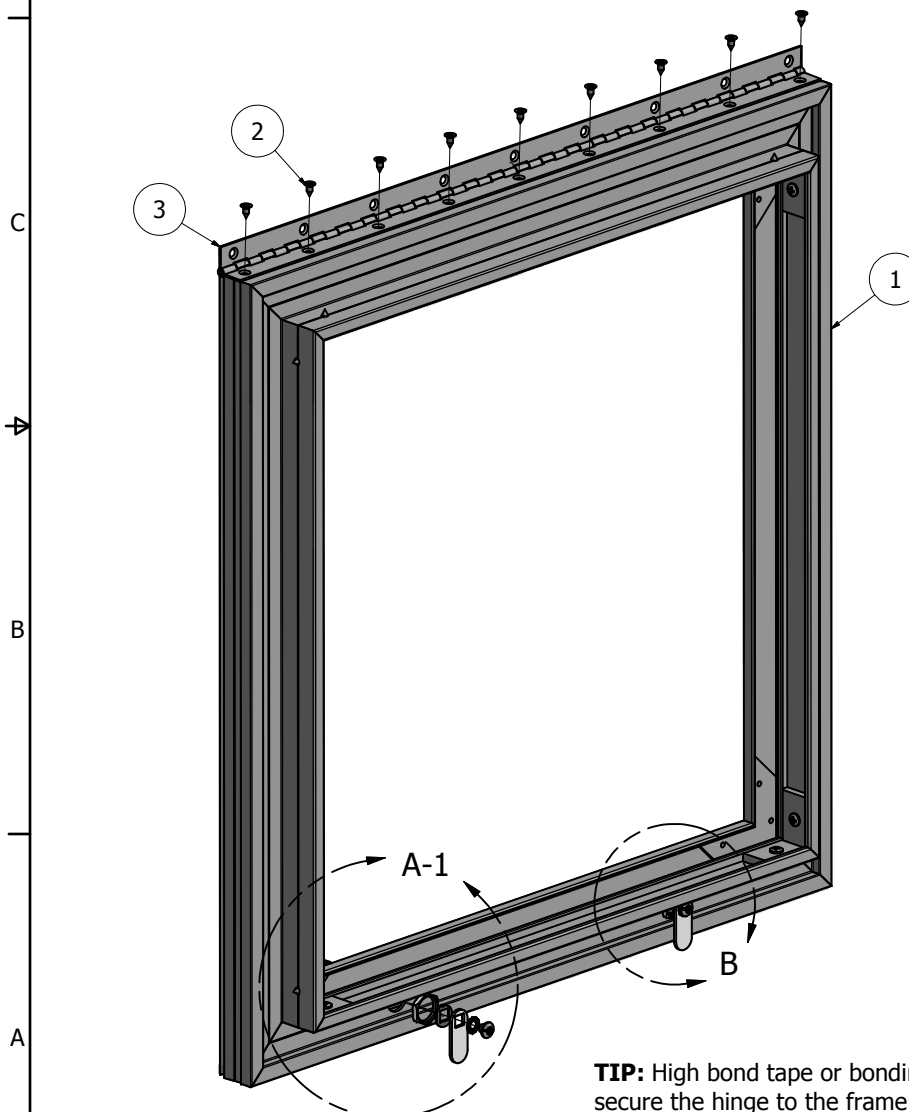

TIP: High bond tape or bonding agents can be used to help secure the hinge to the frame and assist in the installation of the hinge. Be careful not to get the tape on the barrel of the hinge. To do so may cause the hinge not to open properly.

THIS DRAWING WAS CREATED AT NO CHARGE TO ASSIST YOU IN VISUALIZING OUR PROPOSAL. THE DRAWING HEREIN IS THE PROPERTY OF SIGNCOMP. PERMISSION TO COPY OR REVISE THIS DRAWING OR TO USE THIS DRAWING FOR PRODUCTION IS STRICTLY PROHIBITED AND CAN ONLY BE COPIED, REVISED OR USED FOR PRODUCTION WITH THE EXPRESSED WRITTEN PERMISSION OF SIGNCOMP.

DRAWN	Sarah	3/19/2012	SignComp
Centroid X:	0.000 in		
Centroid Y:	0.000 in		TITLE
Principal Moments Ix:	0.000 in ⁴		2Part Outer Frame - 2Part Hinge - 2Part Lock - Assembly
Principal Moments Iy:	0.000 in ⁴		
Section Modulus Ix:	0.000 in ³		DWG NO
Section Modulus Iy:	0.000 in ³		K1941 - Hinge - Lock - Assembly
			REV

PARTS LIST			
ITEM	PART #	DESCRIPTION	NOTES
1	K1959	2Part Large Inner Frame	Assembly
2	K1941	2Part Large Outer Frame	Assembly
31		Hinge Fastener	1/8" Pop Rivet or #8 Counter Sunk Fastener

Ship To:
Sales Order#:

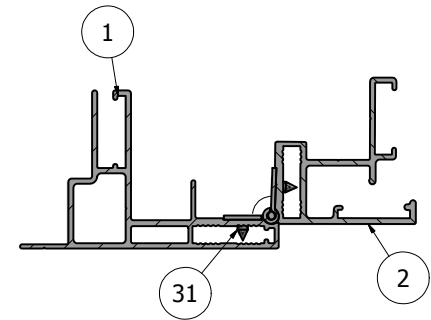
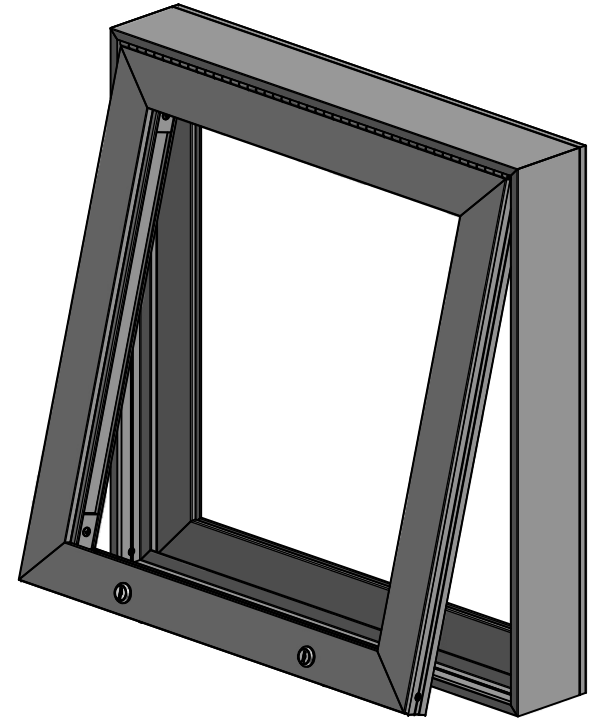
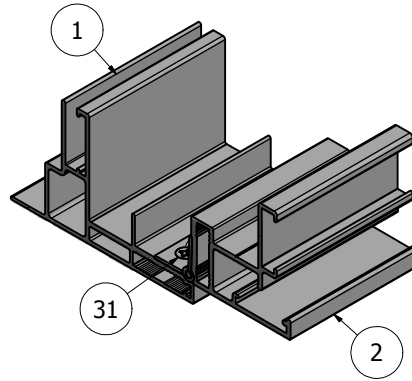
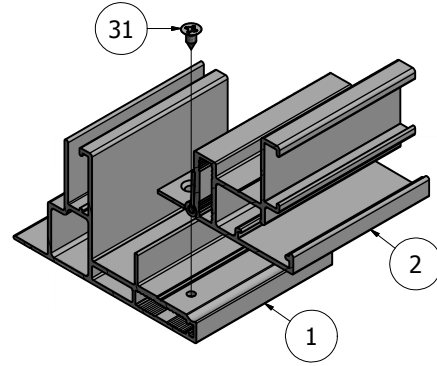
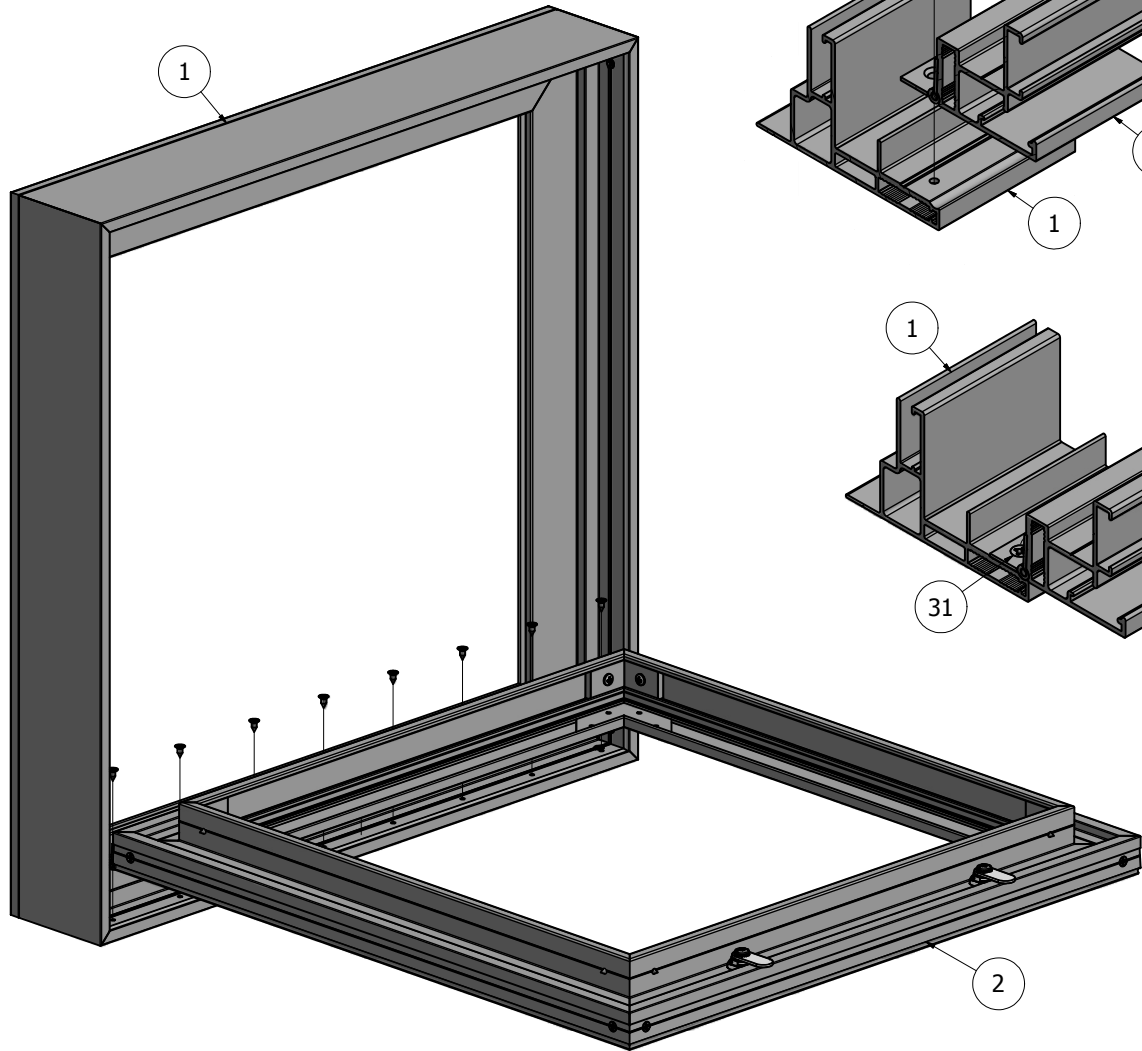

NOTE: PRE-CUT KITS ARE NOT PRE-DRILLED.
(Holes shown in this drawing are for reference only.
Drilling of pilot holes are to be done by fabricator.)

THIS DRAWING WAS CREATED AT NO CHARGE TO ASSIST YOU IN VISUALIZING OUR PROPOSAL. THE DRAWING HEREIN IS THE PROPERTY OF SIGNCOMP. PERMISSION TO COPY OR REVISE THIS DRAWING OR TO USE THIS DRAWING FOR PRODUCTION IS STRICTLY PROHIBITED AND CAN ONLY BE COPIED, REVISED OR USED FOR PRODUCTION WITH THE EXPRESSED WRITTEN PERMISSION OF SIGNCOMP.

DRAWN	SBreihof	6/6/2012	SignComp
Centroid X:	0.000 in	0.000 in	
Centroid Y:	0.000 in	0.000 in	TITLE
Principal Moments Ix:	0.000 in ⁴	0.000 in ⁴	2Part Large Inner and 2Part Large Outer Frame - Assembly
Principal Moments Iy:	0.000 in ⁴	0.000 in ⁴	
Section Modulus Ix:	0.000 in ³	0.000 in ³	DWG NO
Section Modulus Iy:	0.000 in ³	0.000 in ³	K1959-41
			REV

TIP: High bond tape or bonding agents can be used to help secure the hinge to the frame and assist in the installation of the hinge. Be careful not to get the tape on the barrel of the hinge. To do so may cause the hinge not to open properly.