

Parts List			
ITEM	PART#	DESCRIPTION	NOTES
1	K2015	Medium Body	Assembly
2	K2055	1-1/2" Retainer	Assembly
10	5170	Hinge Screw	Drill 3/8" pilot hole
11	5180	Closure Screw	Drill 5/16" pilot hole

Ship To:
Order Number:

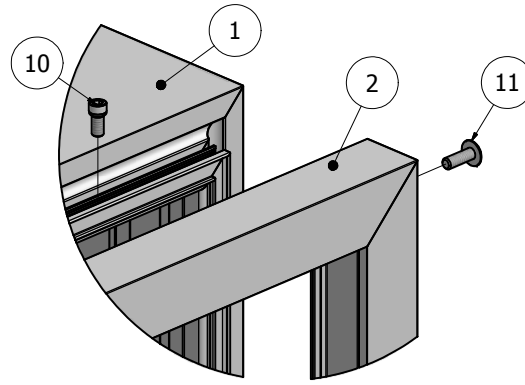

DETAIL A

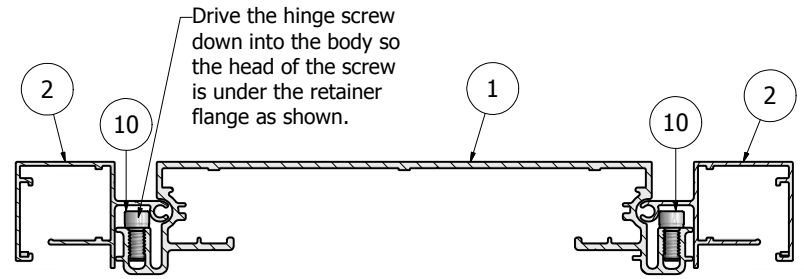
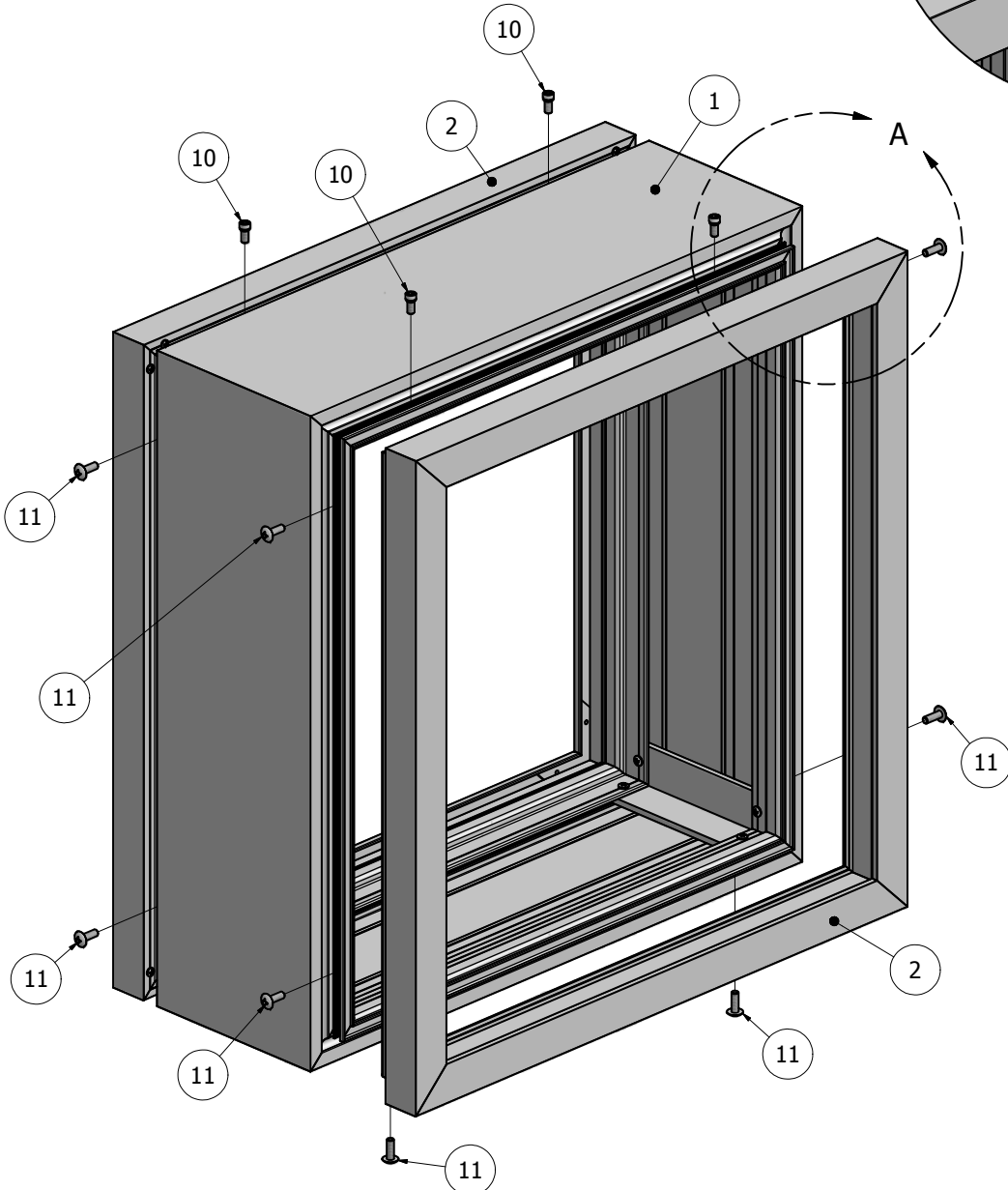
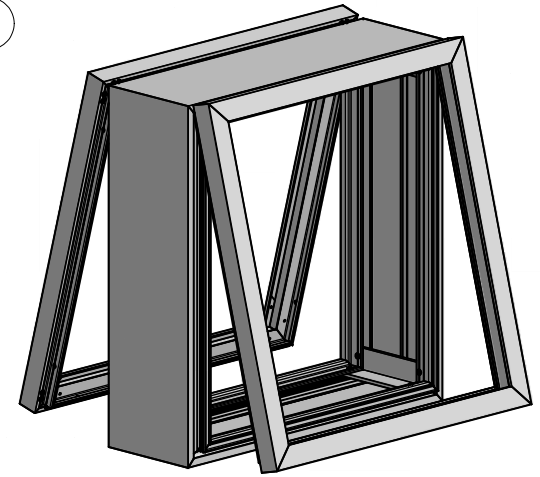

TOP CROSS-SECTION

NOTE: PRE-CUT KITS ARE NOT PRE-DRILLED.
(Holes shown in this drawing are for reference only.
Drilling of pilot holes are to be done by fabricator.)

THIS DRAWING WAS CREATED AT NO CHARGE TO ASSIST YOU IN VISUALIZING OUR PROPOSAL. THE DRAWING HEREIN IS THE PROPERTY OF SIGNCOMP. PERMISSION TO COPY OR REVISE THIS DRAWING OR TO USE THIS DRAWING FOR PRODUCTION IS STRICTLY PROHIBITED AND CAN ONLY BE COPIED, REVISED OR USED FOR PRODUCTION WITH THE EXPRESSED WRITTEN PERMISSION OF SIGNCOMP.

DRAWN	Sarah	3/5/2012	SignComp
Centroid X:	0.000 in		
Centroid Y:	0.000 in		TITLE
Principal Moments Ix:	0.000 in ⁴		Medium Body w/ 1-1/2" Retainer
Principal Moments Iy:	0.000 in ⁴		DWG NO
Section Modulus Ix:	0.000 in ³		KMB-55
Section Modulus Iy:	0.000 in ³		REV

Parts List			
ITE	PART #	DESCRIPTION	NOTES
1	2055	1-1/2" Retainer	Top & Bottm
2	2055	1-1/2" Retainer	Sides
3	5210	Standard Corner Key	
17	5195	1 1-2 Retainer Screw	Pre-drill hole 3/32" on back side of retainer

Ship To:
Order Number:

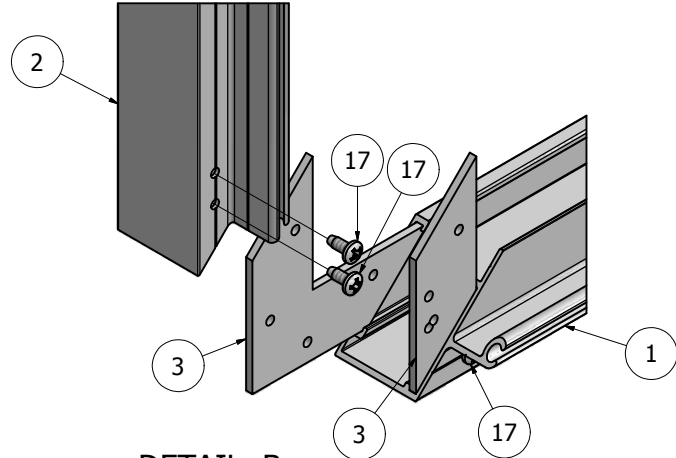
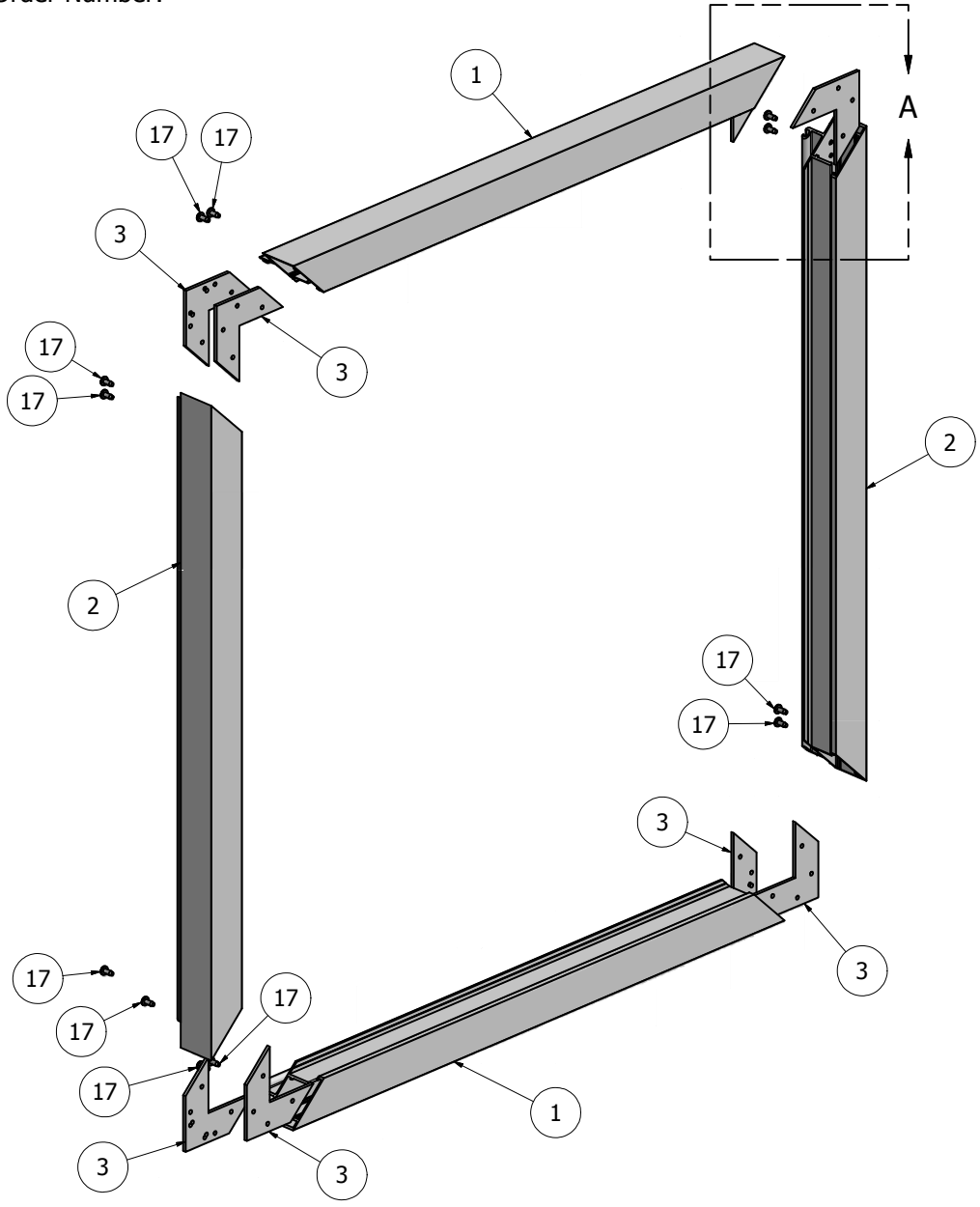

DETAIL B
BACK SIDE

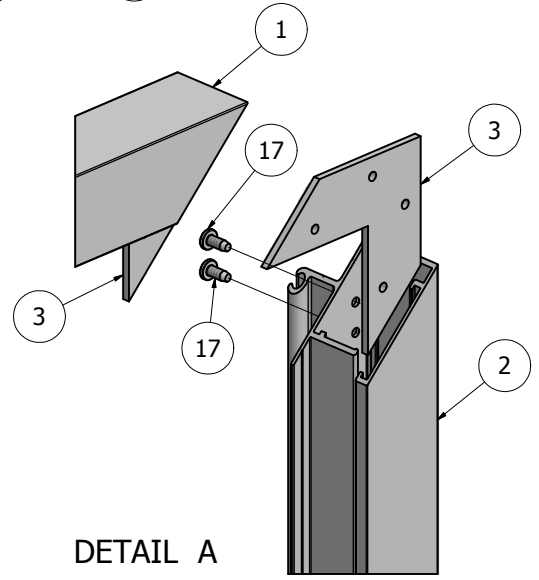

DETAIL A

NOTE: PRE-CUT KITS ARE NOT PRE-DRILLED.
(Holes shown in this drawing are for reference only.
Drilling of pilot holes are to be done by fabricator.)

THIS DRAWING WAS CREATED AT NO CHARGE TO ASSIST YOU IN VISUALIZING OUR PROPOSAL. THE DRAWING HEREIN IS THE PROPERTY OF SIGNCOMP. PERMISSION TO COPY OR REVISE THIS DRAWING OR TO USE THIS DRAWING FOR PRODUCTION IS STRICTLY PROHIBITED AND CAN ONLY BE COPIED, REVISED OR USED FOR PRODUCTION WITH THE EXPRESSED WRITTEN PERMISSION OF SIGNCOMP.

DRAWN	Sarah	3/2/2012	SignComp
Centroid X:	0.000 in	TITLE	
Centroid Y:	0.000 in	1 1-2 Retainer - Assembly	
Principal Moments Ix:	0.000 in ⁴	DWG NO	REV
Principal Moments Iy:	0.000 in ⁴	K2055	
Section Modulus Ix:	0.000 in ³	SHEET 1 OF 1	
Section Modulus Iy:	0.000 in ³		