

Parts List			
ITEM	PART #	DESCRIPTION	NOTES
1	1260	Series 3 Slide Body - Assembly	Slide assembly into post
2	1200	Series 2/3 Reveal	Attached to body
3	1230	Series 3 Rectangular Post with Radius Edges - Assembly	
4	Post Cap	Series 3 Rectangular Post with Radius Edges Cap	Zero Reveal Part #5006, 3/8" Reveal Part #5007, 3/4" Reveal Part #5008
41	5040	Post Cap Screw	2 - #10 x 1/2" counter sunk phillips head screws per post

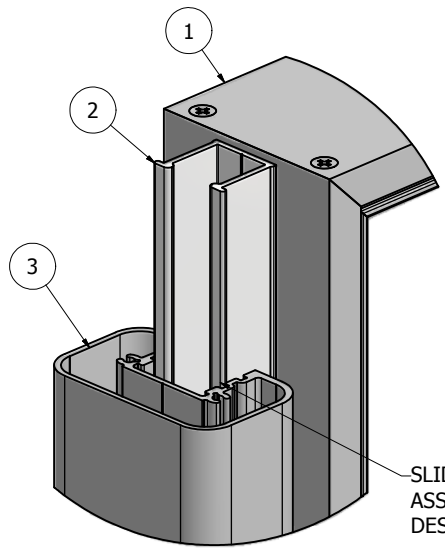

DETAIL A

SLIDE THE BODY/CABINET ASSEMBLY INTO THE DESIRED REVEAL POSTION.

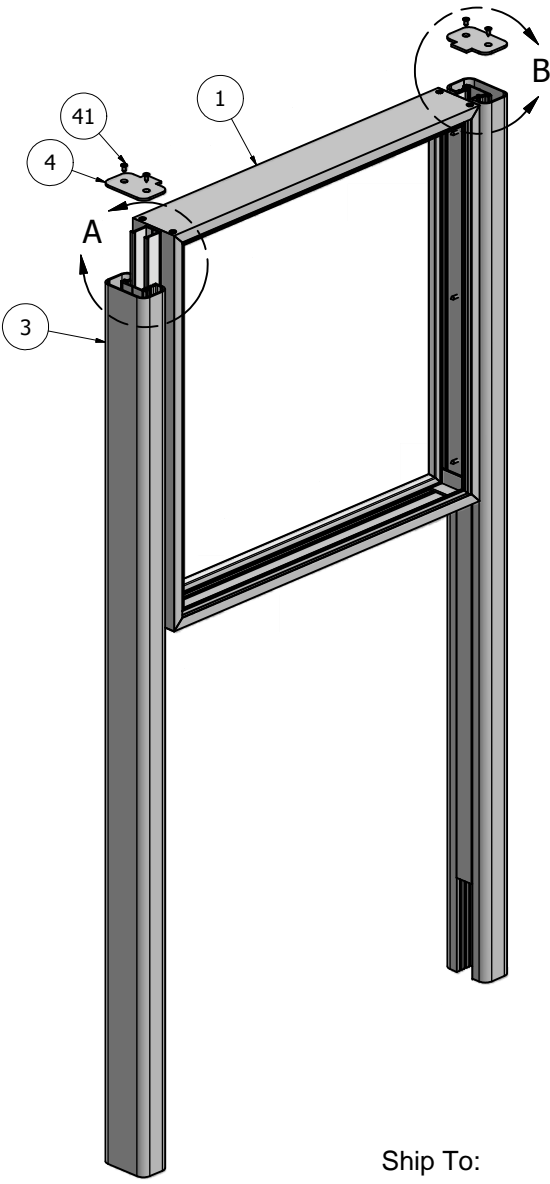
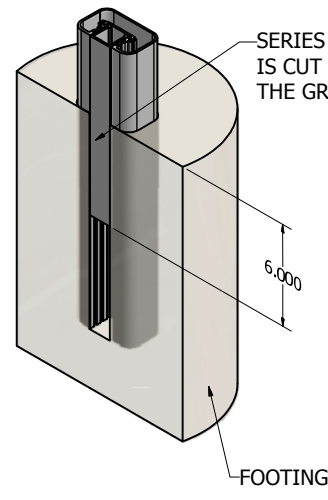

SERIES 2/3 REVEAL/FILLER IS CUT TO FIT 6" BELOW THE GRADE.

FOOTING

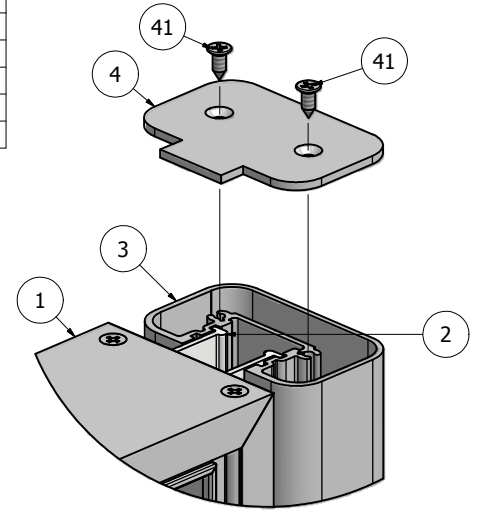

DETAIL B

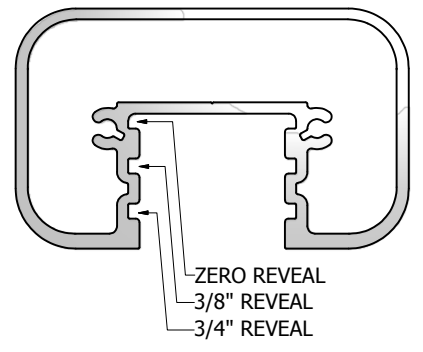

NOTE: PRE-CUT KITS ARE NOT PRE-DRILLED.
 (Holes shown in this drawing are for reference only.
 Drilling of pilot holes are to be done by fabricator.)

THIS DRAWING WAS CREATED AT NO CHARGE TO ASSIST YOU IN VISUALIZING OUR PROPOSAL. THE DRAWING HEREIN IS THE PROPERTY OF SIGNCOMP. PERMISSION TO COPY OR REVISE THIS DRAWING OR TO USE THIS DRAWING FOR PRODUCTION IS STRICTLY PROHIBITED AND CAN ONLY BE COPIED, REVISED OR USED FOR PRODUCTION WITH THE EXPRESSED WRITTEN PERMISSION OF SIGNCOMP.			
DRAWN Steve	5/25/2010	<h1>SignComp</h1> <p>Series 3 Slide Body - Series 3 Rectangular Post with Radius Edges - Assembly</p>	
CHECKED			
QA			
MFG			
APPROVED			
SIZE C	DWG NO K1260-30-00	REV	
SCALE	SHEET 1 OF 1		

Ship To:
 Order #:

Parts List			
ITEM	PART #	DESCRIPTION	NOTES
1	1260	Series 3 Slide Body	Top & Bottom
2	1260	Series 3 Slide Body	Sides
3	5335	Series 3 Slide Body Corner Angle	
49	5240	Slide Body Corner Screw	#10 Counter Sink

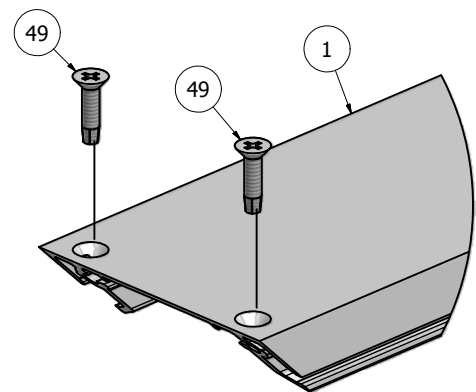
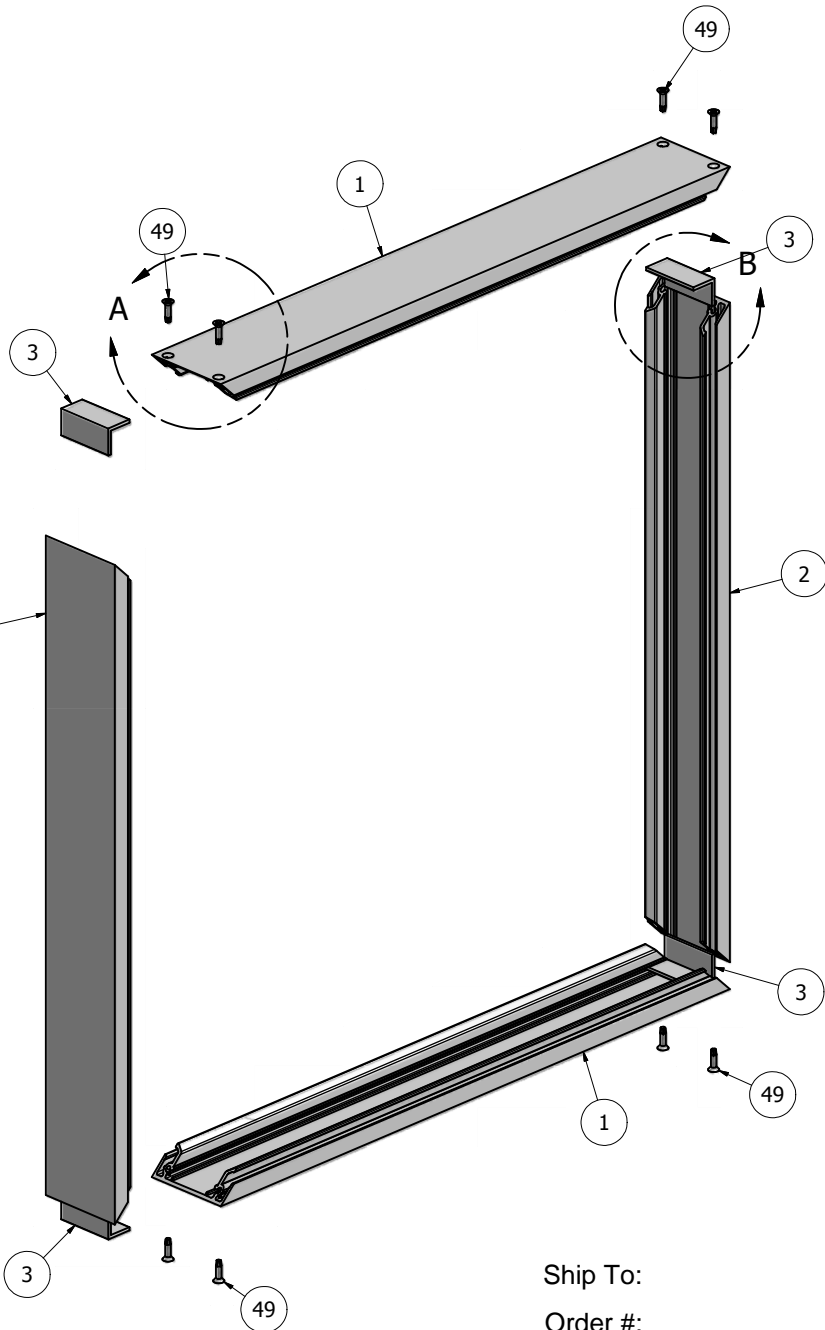

DETAIL A

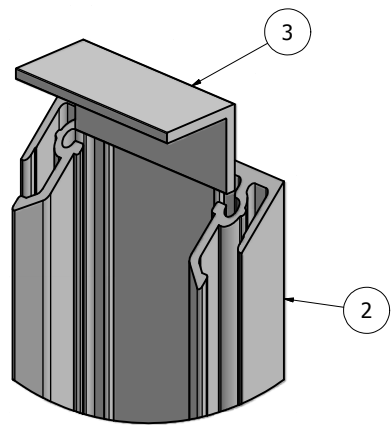

DETAIL B

NOTE: PRE-CUT KITS ARE NOT PRE-DRILLED.
 (Holes shown in this drawing are for reference only.
 Drilling of pilot holes are to be done by fabricator.)

THIS DRAWING WAS CREATED AT NO CHARGE TO ASSIST YOU IN VISUALIZING OUR PROPOSAL. THE DRAWING HEREIN IS THE PROPERTY OF SIGNCOMP. PERMISSION TO COPY OR REVISE THIS DRAWING OR TO USE THIS DRAWING FOR PRODUCTION IS STRICTLY PROHIBITED AND CAN ONLY BE COPIED, REVISED OR USED FOR PRODUCTION WITH THE EXPRESSED WRITTEN PERMISSION OF SIGNCOMP.

DRAWN	4/1/2010	<h1>SignComp</h1> <p>Series 3 Slide Body - Assembly</p>			
CHECKED					
QA					
MFG					
APPROVED					
SIZE	C	DWG NO	K1260	REV	
SCALE		SHEET 1 OF 1			

Ship To:
 Order #:

Parts List			
ITEM	PART #	DESCRIPTION	NOTES
1	1260	Series 3 Slide Body	Assembly
2	1200	Series 2/3 Reveal	Attach to Slide Body
42	5220	Reval to Body Screw	Drill 5/32" pilot hole 12" OC

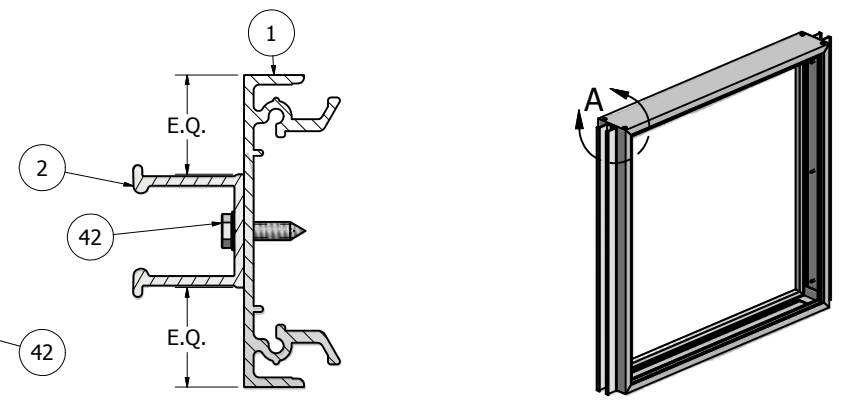
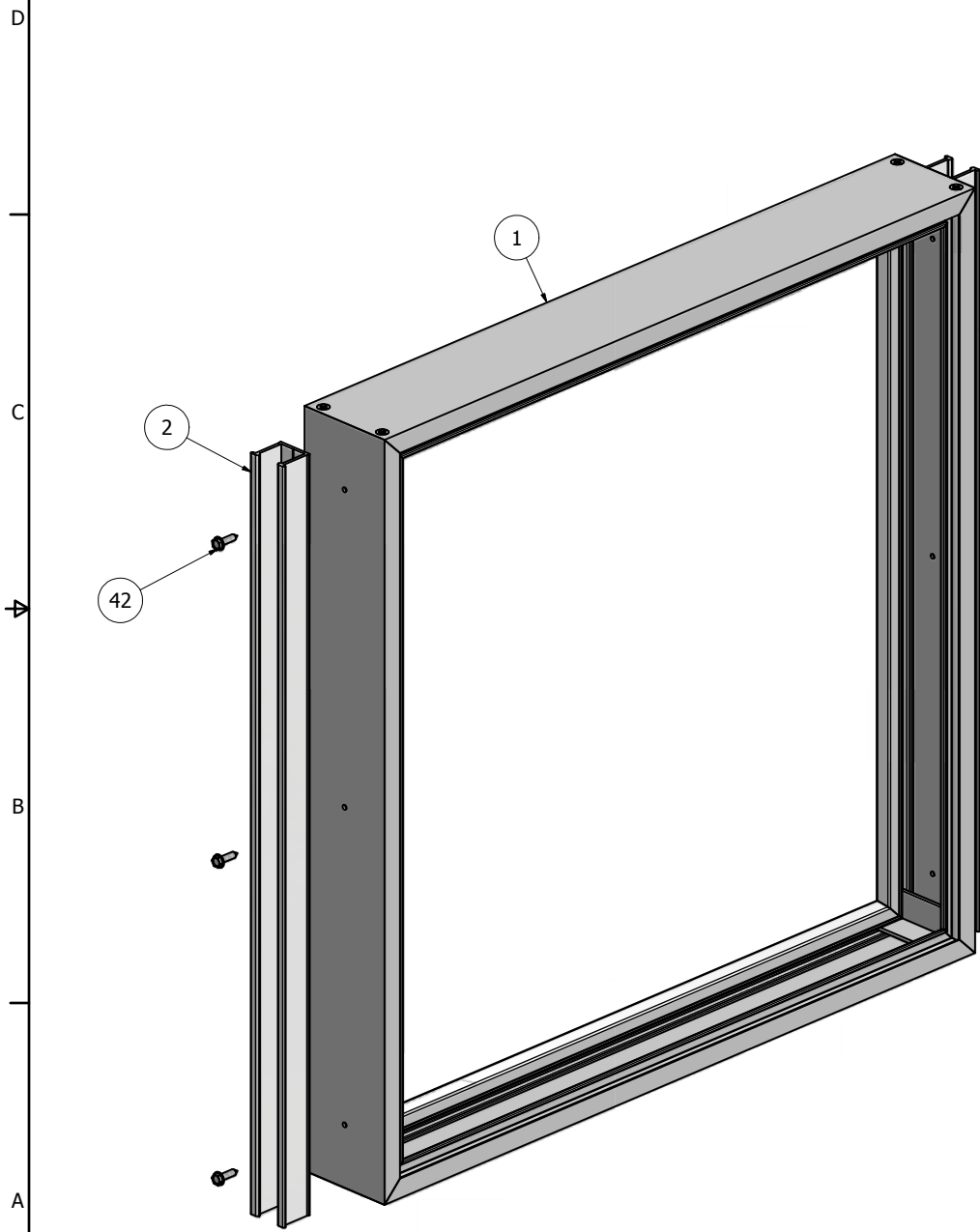

SECTION B-B

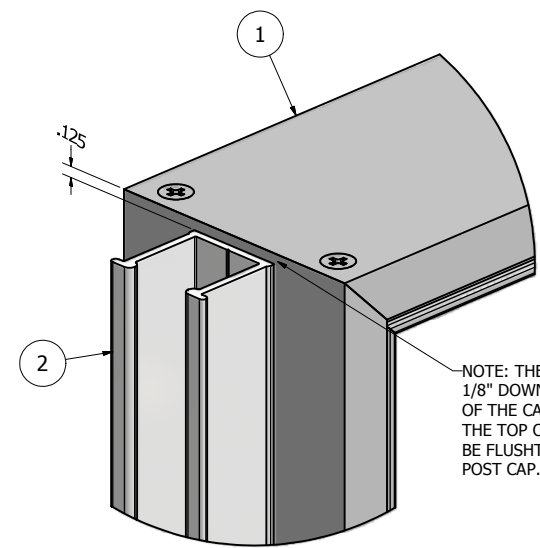

NOTE: THE REVEAL IS PLACED 1/8" DOWN FROM THE TOP OF THE CABINET THE ALLOWS THE TOP OF THE CABINET TO BE FLUSHTH THE TOP OF THE POST CAP.

DETAIL A

NOTE: PRE-CUT KITS ARE NOT PRE-DRILLED.
 (Holes shown in this drawing are for reference only.
 Drilling of pilot holes are to be done by fabricator.)

THIS DRAWING WAS CREATED AT NO CHARGE TO ASSIST YOU IN VISUALIZING OUR PROPOSAL. THE DRAWING HEREIN IS THE PROPERTY OF SIGNCOMP. PERMISSION TO COPY OR REVISE THIS DRAWING OR TO USE THIS DRAWING FOR PRODUCTION IS STRICTLY PROHIBITED AND CAN ONLY BE COPIED, REVISED OR USED FOR PRODUCTION WITH THE EXPRESSED WRITTEN PERMISSION OF SIGNCOMP.

DRAWN	4/1/2010	SignComp	
CHECKED			
QA		TITLE	
MFG		Series 3 Slide Body - Series 2/3 Reveal - Assembly	
APPROVED		SIZE	DWG NO
		C	K1260-00
		SCALE	REV
			SHEET 1 OF 1

Ship To:
 Order #:

Parts List			
ITEM	PART #	DESCRIPTION	NOTES
1	1230	Series 3, 3-1/4" Rectangular Post with Radius Edges	
2	1200	Series 2/3 Reveal	Tack weld or mechanically fasten to post.

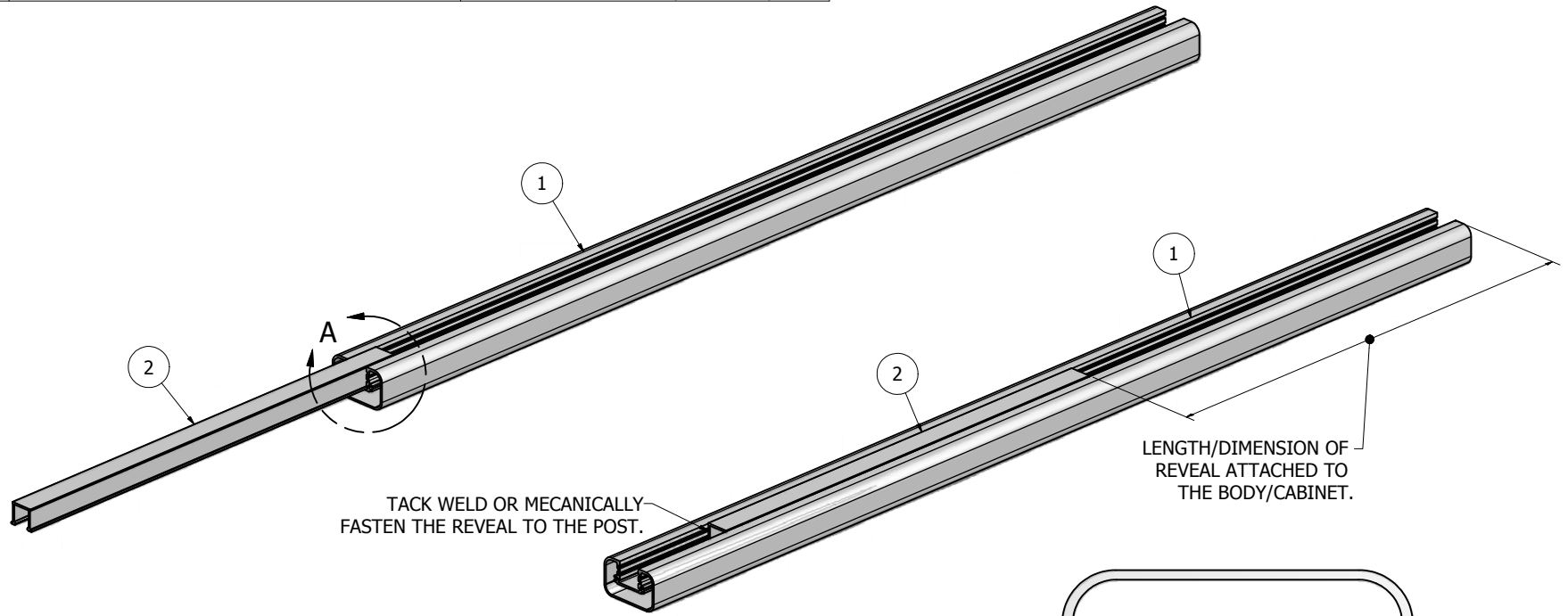

TACK WELD OR MECANICALLY FASTEN THE REVEAL TO THE POST.

LENGTH/DIMENSION OF REVEAL ATTACHED TO THE BODY/CABINET.

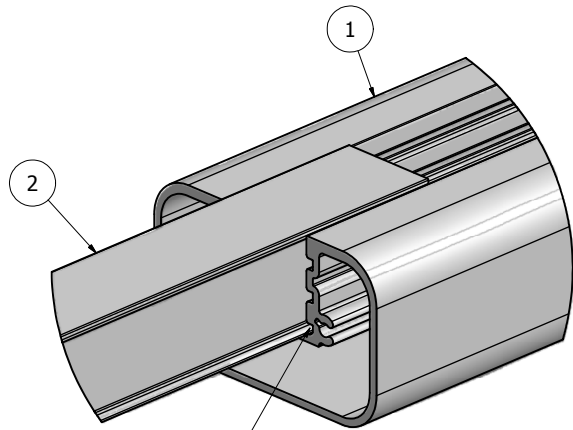
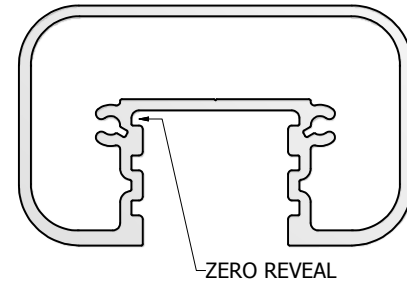

INSERT THE REVEAL/FILLER INTO THE ZERO REVEAL POSITION. SLIDED IT UP INTO THE POST.

DETAIL A

NOTE: PRE-CUT KITS ARE NOT PRE-DRILLED.

(Holes shown in this drawing are for reference only. Drilling of pilot holes are to be done by fabricator.)

THIS DRAWING WAS CREATED AT NO CHARGE TO ASSIST YOU IN VISUALIZING OUR PROPOSAL. THE DRAWING HEREIN IS THE PROPERTY OF SIGNCOMP. PERMISSION TO COPY OR REVISE THIS DRAWING OR TO USE THIS DRAWING FOR PRODUCTION IS STRICTLY PROHIBITED AND CAN ONLY BE COPIED, REVISED OR USED FOR PRODUCTION WITH THE EXPRESSED WRITTEN PERMISSION OF SIGNCOMP.

DRAWN	4/5/2010	SignComp	
CHECKED			
QA		TITLE	
MFG		Series 3, 3-1/4" Rectangular Post with Radius Edges - Series 2/3 Reveal - Assembly	
APPROVED		SIZE	DWG NO
		C	K1230-00
		SCALE	SHEET 1 OF 1

Ship To:

Order #: