

Parts List			
ITEM	PART #	DESCRIPTION	NOTES
1	1510	Series 7 Rectangular Post	
2	1550	Series 7 Reveal	Tack weld or mechanically fasten to post

Ship To:

Order Number:

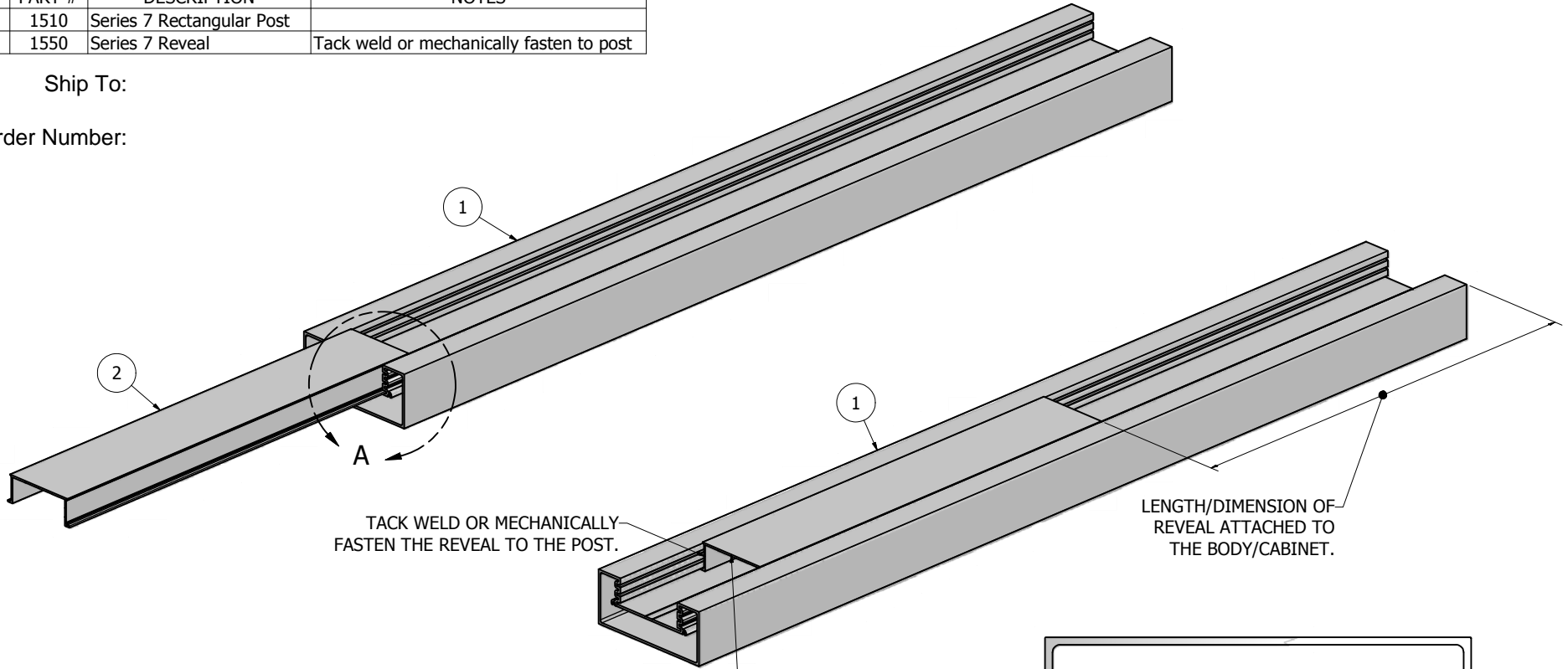

TACK WELD OR MECHANICALLY FASTEN THE REVEAL TO THE POST.

LENGTH/DIMENSION OF REVEAL ATTACHED TO THE BODY/CABINET.

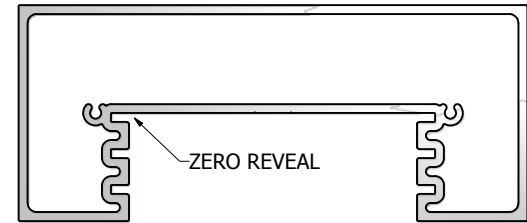

**NOTE: PRE-CUT KITS ARE NOT PRE-DRILLED.**

(Holes shown in this drawing are for reference only. Drilling of pilot holes are to be done by fabricator.)

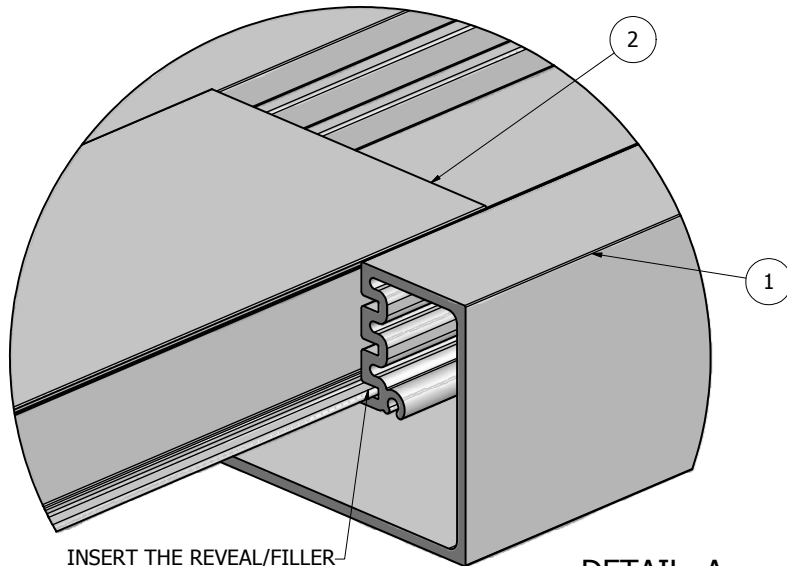

INSERT THE REVEAL/FILLER INTO THE ZERO REVEAL POSITION. SLIDE IT UP INTO THE POST.

DETAIL A

THIS DRAWING WAS CREATED AT NO CHARGE TO ASSIST YOU IN VISUALIZING OUR PROPOSAL. THE DRAWING HEREIN IS THE PROPERTY OF SIGNCOMP. PERMISSION TO COPY OR REVISE THIS DRAWING OR TO USE THIS DRAWING FOR PRODUCTION IS STRICTLY PROHIBITED AND CAN ONLY BE COPIED, REVISED OR USED FOR PRODUCTION WITH THE EXPRESSED WRITTEN PERMISSION OF SIGNCOMP.

DRAWN	8/6/2009	<b>SignComp</b>	
Steve			
CHECKED		TITLE	
QA		Series 7 Rectangular Post and Reveal/Filler Assembly	
MFG		SIZE	DWG NO
APPROVED		C	1510-50
		SCALE	SHEET 1 OF 1