

| Parts List |        |                        |  |
|------------|--------|------------------------|--|
| ITEM       | PART # | DESCRIPTION            | NOTES                                    |
| 1          | 1500   | Series 7 Radius Post   |  |
| 2          | 1550   | Series 7 Reveal/Filler | Tack weld or mechanically fasten to post |

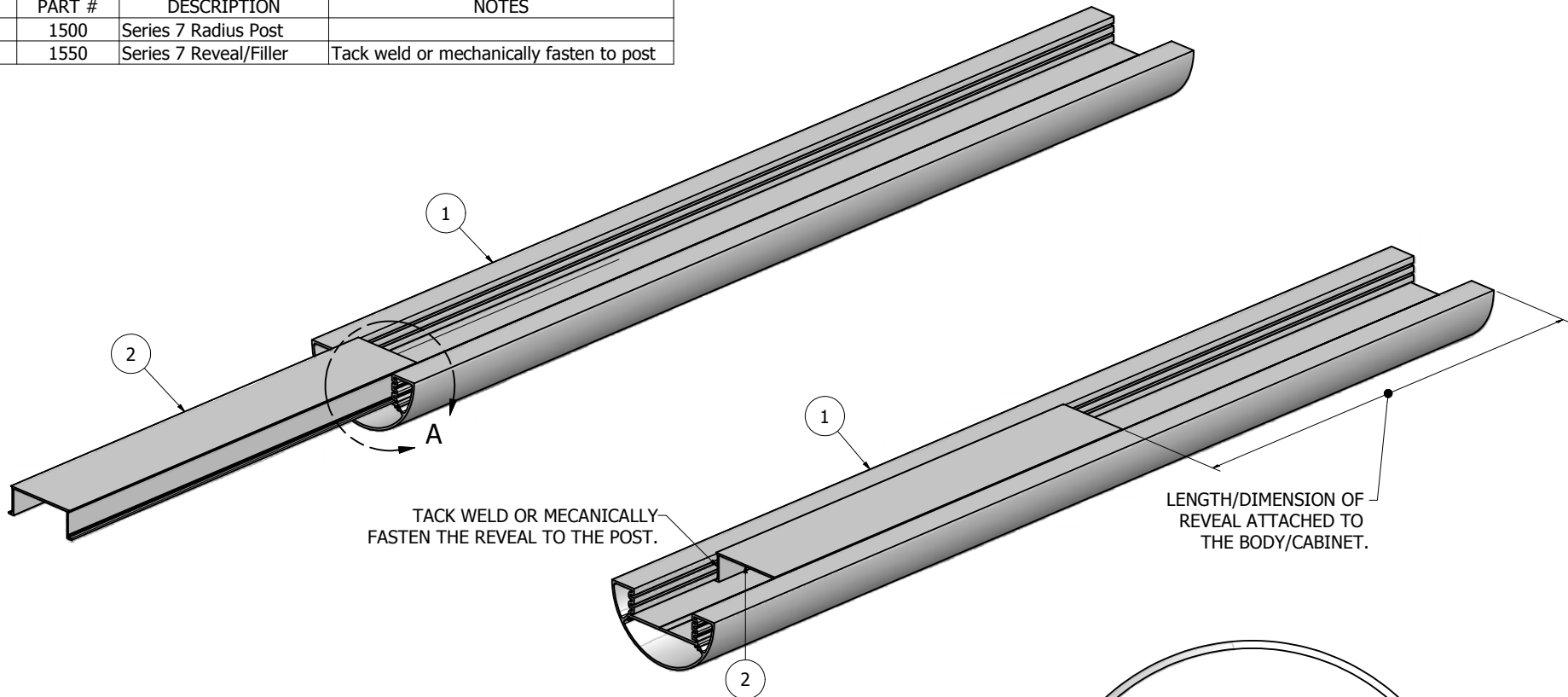

TACK WELD OR MECANICALLY FASTEN THE REVEAL TO THE POST.

LENGTH/DIMENSION OF REVEAL ATTACHED TO THE BODY/CABINET.

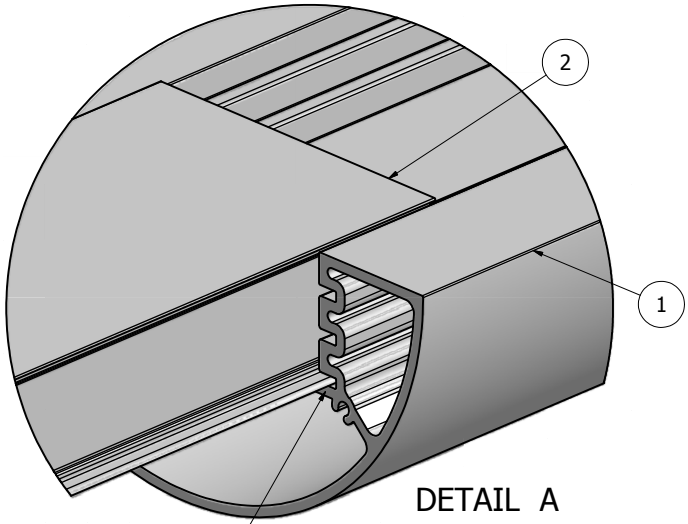

DETAIL A

INSERT THE REVEAL/FILLER INTO THE ZERO REVEAL POSTION. SLIDED IT UP INTO THE POST.

Ship To:

Order Number:

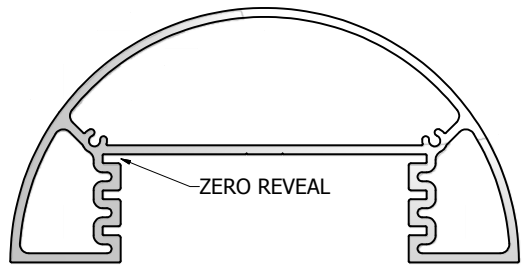

**NOTE: PRE-CUT KITS ARE NOT PRE-DRILLED.**

(Holes shown in this drawing are for reference only. Drilling of pilot holes are to be done by fabricator.)

THIS DRAWING WAS CREATED AT NO CHARGE TO ASSIST YOU IN VISUALIZING OUR PROPOSAL. THE DRAWING HEREIN IS THE PROPERTY OF SIGNCOMP. PERMISSION TO COPY OR REVISE THIS DRAWING OR TO USE THIS DRAWING FOR PRODUCTION IS STRICTLY PROHIBITED AND CAN ONLY BE COPIED, REVISED OR USED FOR PRODUCTION WITH THE EXPRESSED WRITTEN PERMISSION OF SIGNCOMP.

|          |          |   |              |
|----------|----------|---|--------------|
| DRAWN    | 8/5/2009 | <b>SignComp</b>                                 |              |
| CHECKED  |          |   |              |
| QA       |          | TITLE   |              |
| MFG      |          | Series 7 Radius Post and Reveal/Filler Assembly |              |
| APPROVED |          | SIZE  | DWG NO       |
|          |          | C   | 1500-50      |
|          |          | SCALE   | SHEET 1 OF 1 |