

Parts List			
ITEM	PART #	DESCRIPTION	NOTES
1	K1570-50	Series 7 Bleed Body Assembly	Slide assembly into post.
2	K1510-50	Series 7 Rectangular Post Assembly	
3	1550	Series 7 Reveal	Attached to Body
4	Post Cap	Series 7 Rectangular Post Cap	Zero Reveal Part #5030, 1/2" Reveal Part #5034, 1" Reveal Part #5036
41	5040	Cap Screw	2 - #10 x 1/2" counter sunk phillips head screws

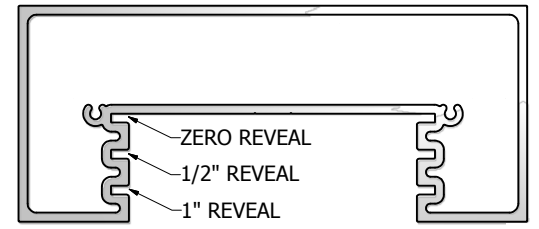
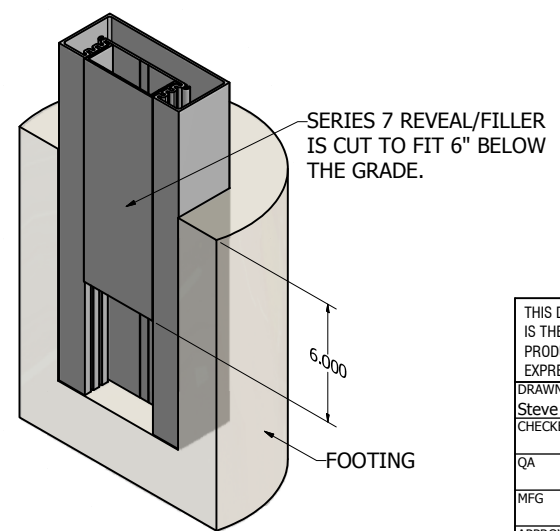
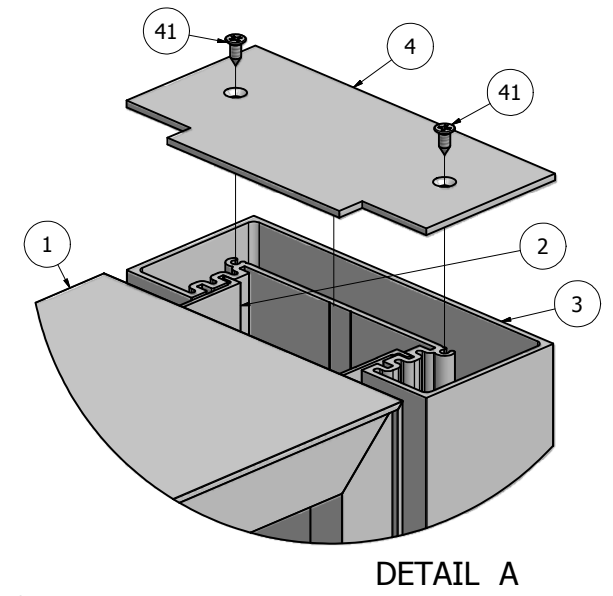
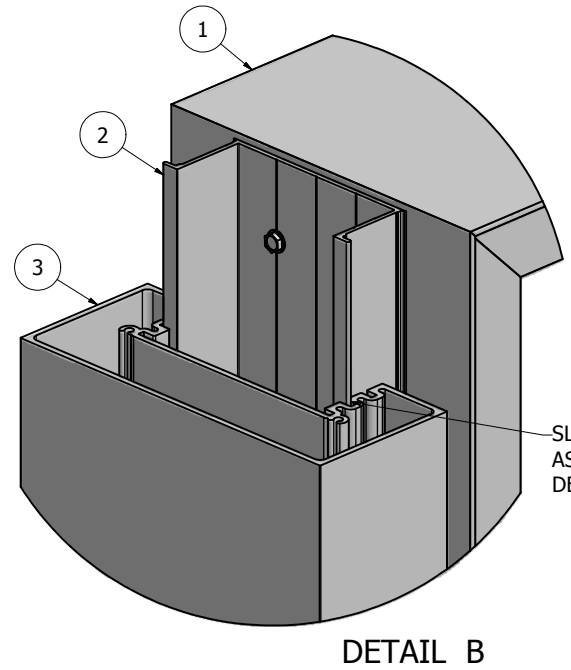
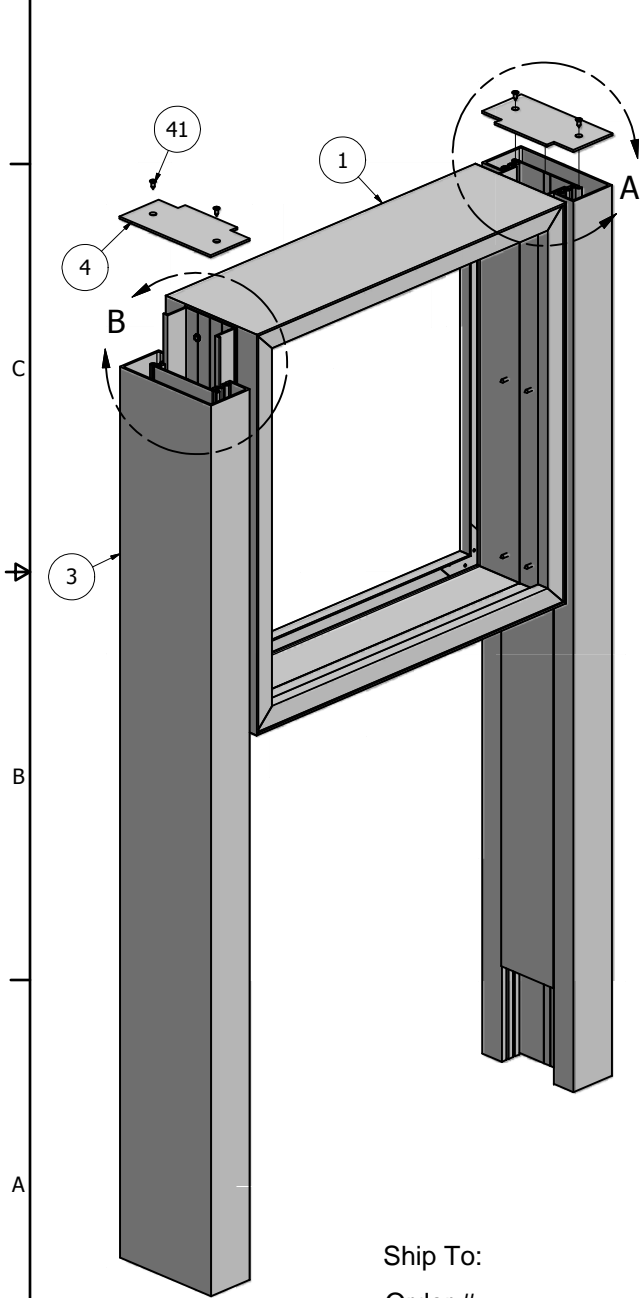

NOTE: PRE-CUT KITS ARE NOT PRE-DRILLED.
 (Holes shown in this drawing are for reference only.
 Drilling of pilot holes are to be done by fabricator.)

Ship To:
 Order #:

THIS DRAWING WAS CREATED AT NO CHARGE TO ASSIST YOU IN VISUALIZING OUR PROPOSAL. THE DRAWING HEREIN IS THE PROPERTY OF SIGNCOMP. PERMISSION TO COPY OR REVISE THIS DRAWING OR TO USE THIS DRAWING FOR PRODUCTION IS STRICTLY PROHIBITED AND CAN ONLY BE COPIED, REVISED OR USED FOR PRODUCTION WITH THE EXPRESSED WRITTEN PERMISSION OF SIGNCOMP.

DRAWN	12/9/2009	SignComp	
Steve			
CHECKED		TITLE	
QA		Series 7 Bleed Body - Series 7 Rectangular Post - Assembly	
MFG		SIZE	DWG NO
APPROVED		C	K1570-10
		SCALE	REV

SHEET 1 OF 1

Parts List			
ITEM	PART #	DESCRIPTION	NOTES
1	1570	Series 7 Bleed Body	Top & Bottom
2	1570	Series 7 Bleed Body	Sides
3	5210	Corner Key	

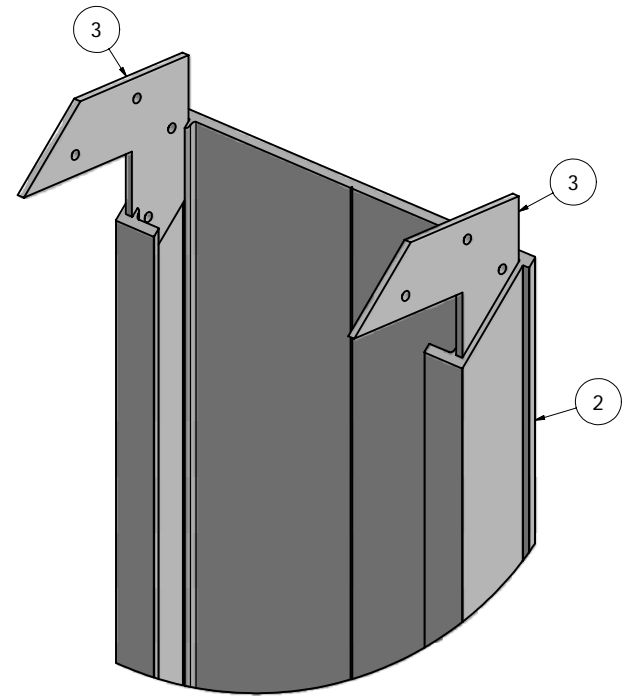
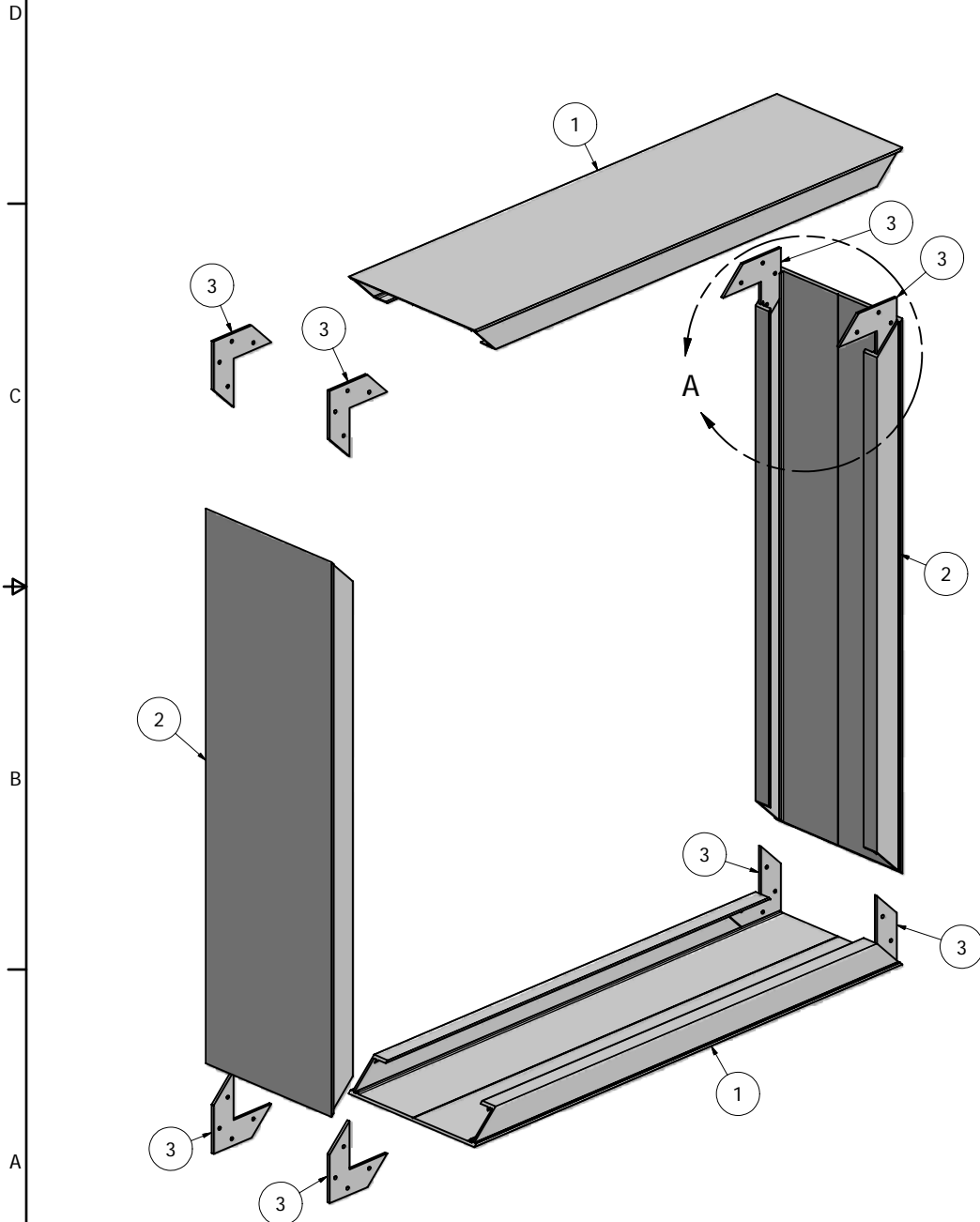

DETAIL A

NOTE: PRE-CUT KITS ARE NOT PRE-DRILLED.
 (Holes shown in this drawing are for reference only.
 Drilling of pilot holes are to be done by fabricator.)

THIS DRAWING WAS CREATED AT NO CHARGE TO ASSIST YOU IN VISUALIZING OUR PROPOSAL. THE DRAWING HEREIN IS THE PROPERTY OF SIGNCOMP. PERMISSION TO COPY OR REVISE THIS DRAWING OR TO USE THIS DRAWING FOR PRODUCTION IS STRICTLY PROHIBITED AND CAN ONLY BE COPIED, REVISED OR USED FOR PRODUCTION WITH THE EXPRESSED WRITTEN PERMISSION OF SIGNCOMP.			
DRAWN	Steve	2/6/2009	<div style="text-align: center;"> <h1>SignComp</h1> <p>Series 7 Bleed Body - Assembly</p> </div>
CHECKED			
QA			
MFG			
APPROVED			
	SIZE	DWG NO	REV
	C	K1570	
	SCALE	SHEET 1 OF 1	

Ship To:
 Order #:

Parts List			
ITEM	PART #	DESCRIPTION	NOTES
1	1570	Series 7 Bleed body	Assembly
2	1550	Series 7 Reveal	Attach to Bleed Body
3	5220	Reveal to Body Screw	Drill 3/32" Pilot Hole in pairs 12" OC

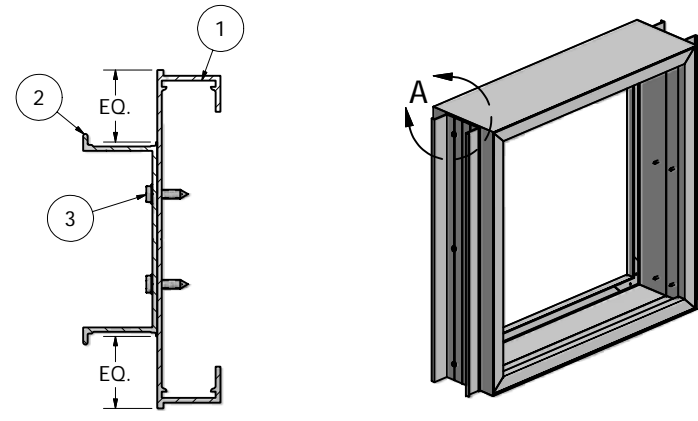
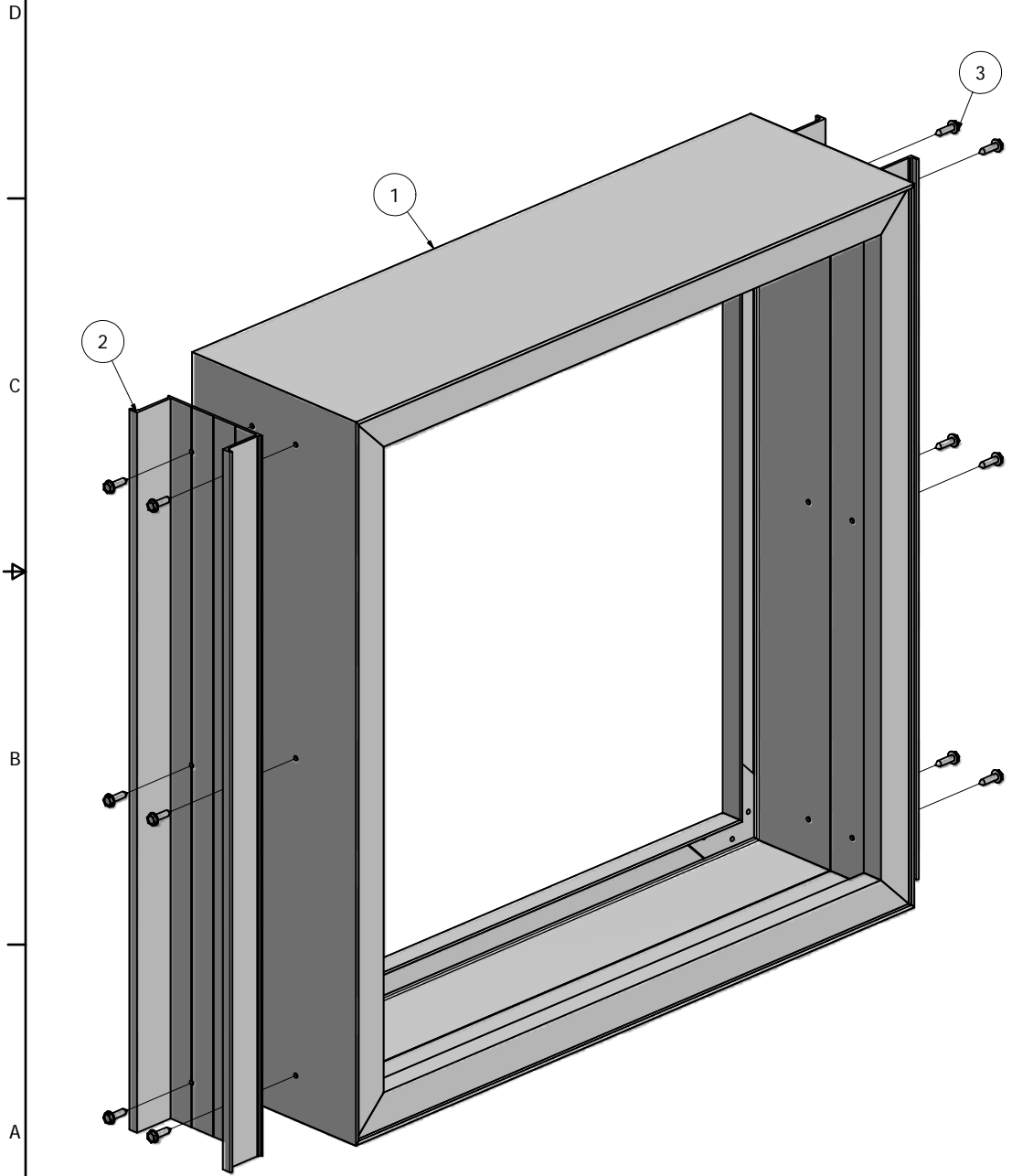

SECTION B-B

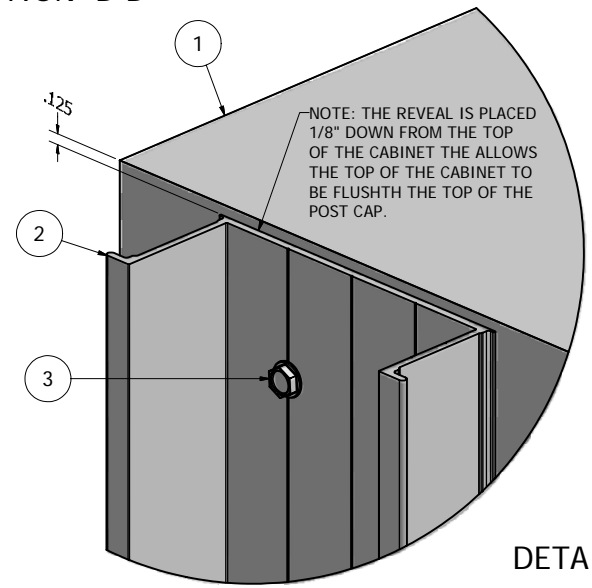

DETAIL A

NOTE: PRE-CUT KITS ARE NOT PRE-DRILLED.
 (Holes shown in this drawing are for reference only.
 Drilling of pilot holes are to be done by fabricator.)

Ship To:
 Order #:

THIS DRAWING WAS CREATED AT NO CHARGE TO ASSIST YOU IN VISUALIZING OUR PROPOSAL. THE DRAWING HEREIN IS THE PROPERTY OF SIGNCOMP. PERMISSION TO COPY OR REVISE THIS DRAWING OR TO USE THIS DRAWING FOR PRODUCTION IS STRICTLY PROHIBITED AND CAN ONLY BE COPIED, REVISED OR USED FOR PRODUCTION WITH THE EXPRESSED WRITTEN PERMISSION OF SIGNCOMP.			
DRAWN	8/5/2009	<div style="text-align: center;">SignComp</div>	
CHECKED			
QA			
MFG			
APPROVED			
TITLE		K1570 with Series 7 Reveal - Reval Attachment Detail	
SIZE	C	DWG NO	K1570-50
SCALE		REV	
			SHEET 1 OF 1

Parts List			
ITEM	PART #	DESCRIPTION	NOTES
1	1510	Series 7 Rectangular Post	
2	1550	Series 7 Reveal	Tack weld or mechanically fasten to post

Ship To:

Order #:

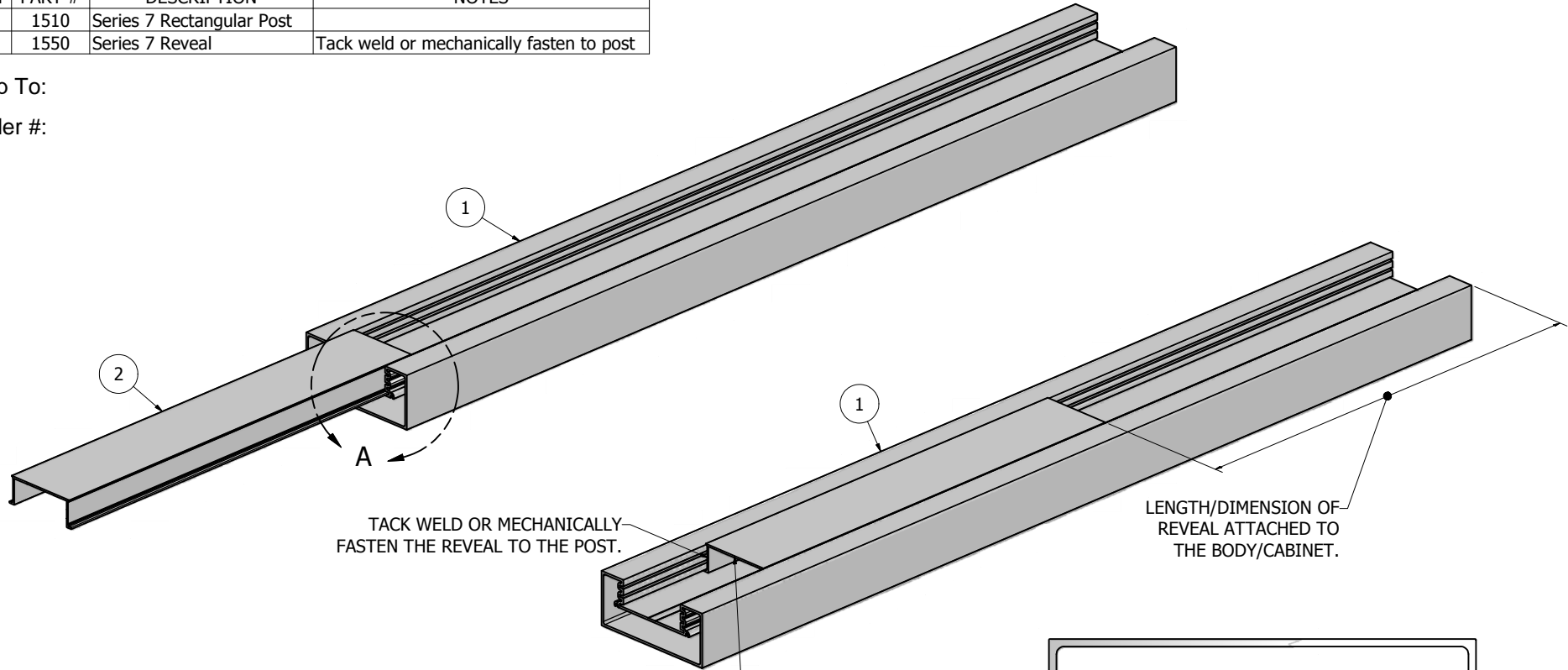

TACK WELD OR MECHANICALLY FASTEN THE REVEAL TO THE POST.

LENGTH/DIMENSION OF REVEAL ATTACHED TO THE BODY/CABINET.

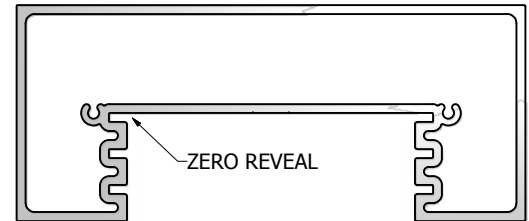

NOTE: PRE-CUT KITS ARE NOT PRE-DRILLED.
 (Holes shown in this drawing are for reference only. Drilling of pilot holes are to be done by fabricator.)

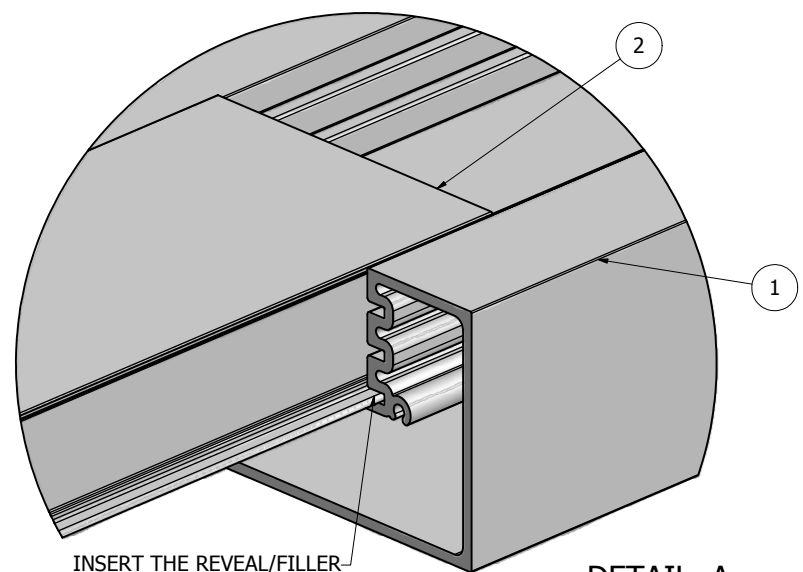

INSERT THE REVEAL/FILLER INTO THE ZERO REVEAL POSITION. SLIDE IT UP INTO THE POST.

DETAIL A

THIS DRAWING WAS CREATED AT NO CHARGE TO ASSIST YOU IN VISUALIZING OUR PROPOSAL. THE DRAWING HEREIN IS THE PROPERTY OF SIGNCOMP. PERMISSION TO COPY OR REVISE THIS DRAWING OR TO USE THIS DRAWING FOR PRODUCTION IS STRICTLY PROHIBITED AND CAN ONLY BE COPIED, REVISED OR USED FOR PRODUCTION WITH THE EXPRESSED WRITTEN PERMISSION OF SIGNCOMP.			
DRAWN	8/6/2009	SignComp	
CHECKED			
QA			
MFG			
APPROVED			
TITLE		Series 7 Rectangular Post and Reveal/Filler Assembly	
SIZE	C	DWG NO	K1510-50
SCALE			SHEET 1 OF 1