

Parts List

ITEM	PART #	DESCRIPTION	NOTES
1	K1560-50	Series 7 Slide Body Assembly	Slide assembly into post
2	1550	Series 7 Reveal	attached to body
3	K1530-50	Series 7 Triangular Post Assembly	
4	Post Cap	Series 7 Triangular Post Cap	Zero Reveal Part #5425, 1/2" Reveal Part #5426, 1" Reveal Part #5427
41	5040	Cap Screw	3 - #10 x 1/2" counter sunk phillips head screws

D

C

B

A

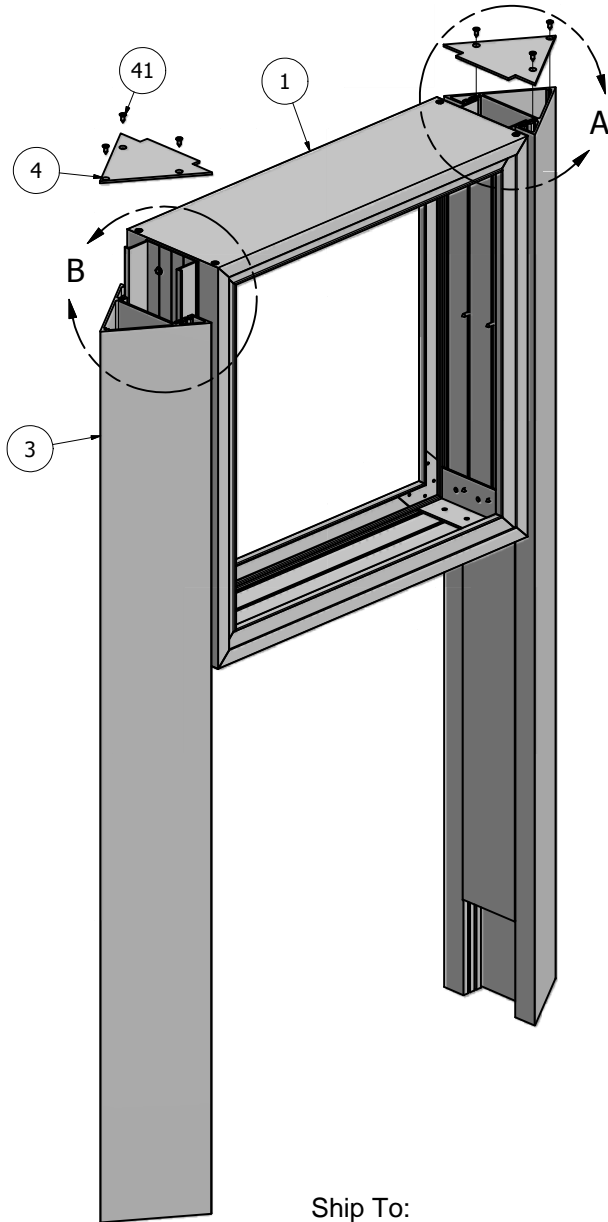

Ship To:  
Order #:

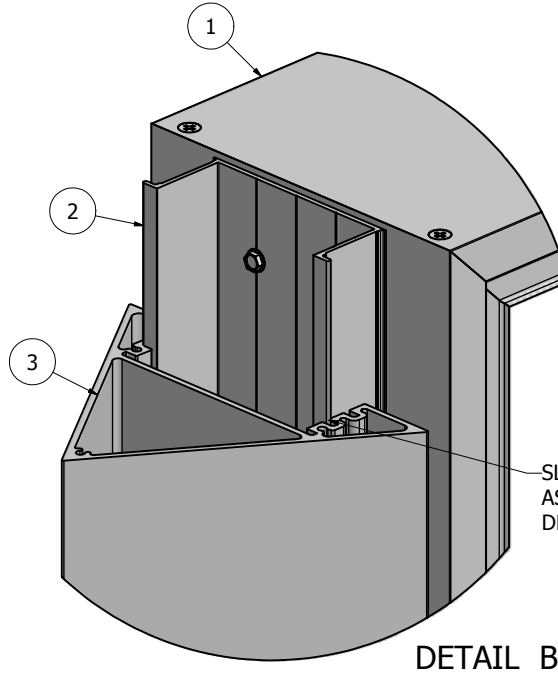

DETAIL B

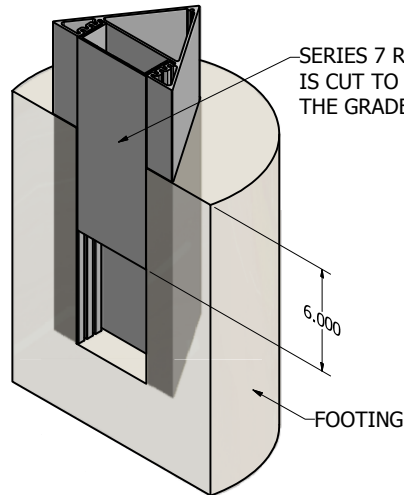

SERIES 7 REVEAL/FILLER IS CUT TO FIT 6" BELOW THE GRADE.

FOOTING

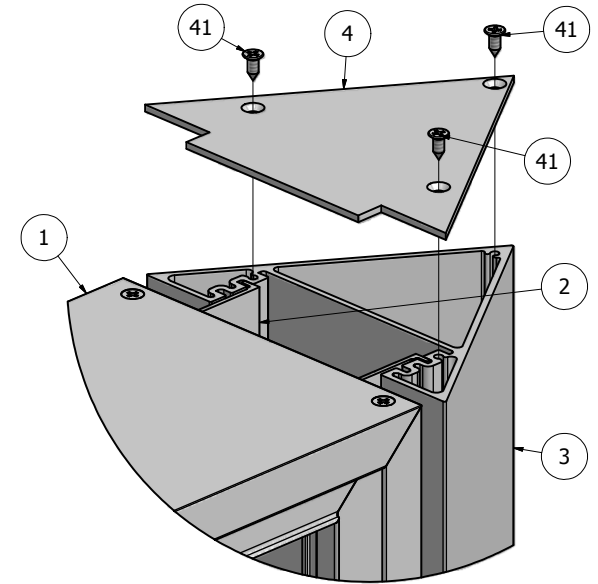

DETAIL A

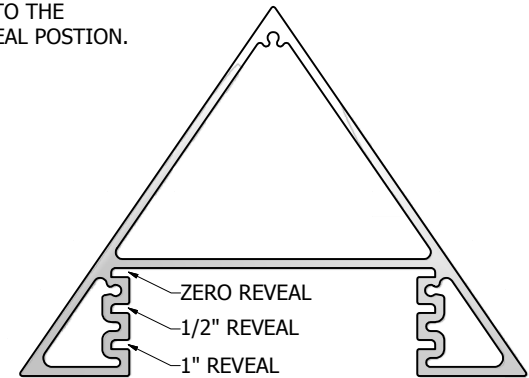

**NOTE: PRE-CUT KITS ARE NOT PRE-DRILLED.**

(Holes shown in this drawing are for reference only. Drilling of pilot holes are to be done by fabricator.)

THIS DRAWING WAS CREATED AT NO CHARGE TO ASSIST YOU IN VISUALIZING OUR PROPOSAL. THE DRAWING HEREIN IS THE PROPERTY OF SIGNCOMP. PERMISSION TO COPY OR REVISE THIS DRAWING OR TO USE THIS DRAWING FOR PRODUCTION IS STRICTLY PROHIBITED AND CAN ONLY BE COPIED, REVISED OR USED FOR PRODUCTION WITH THE EXPRESSED WRITTEN PERMISSION OF SIGNCOMP.

DRAWN	12/10/2009	<b>SignComp</b>	
Steve			
CHECKED		TITLE	
QA		Series 7 Slide Body - Series 7 Triangular Post - Assembly	
MFG		SIZE	DWG NO
APPROVED		C	K1560-30-50
		SCALE	REV
			SHEET 1 OF 1

4

3

4

2

1

D

C

B

A

A

Parts List			
ITEM	PART #	DESCRIPTION	NOTES
1	1560	Series 7 Slide Body	Top & Bottom
2	1560	Series 7 Slide Body	Sides
3	5210	Corner Key	
4	5348	Series 7 Slide Body Corner Angle	
50	5240	Series 7 Slide Body Corner Screw	Drill #10 Counter Sink

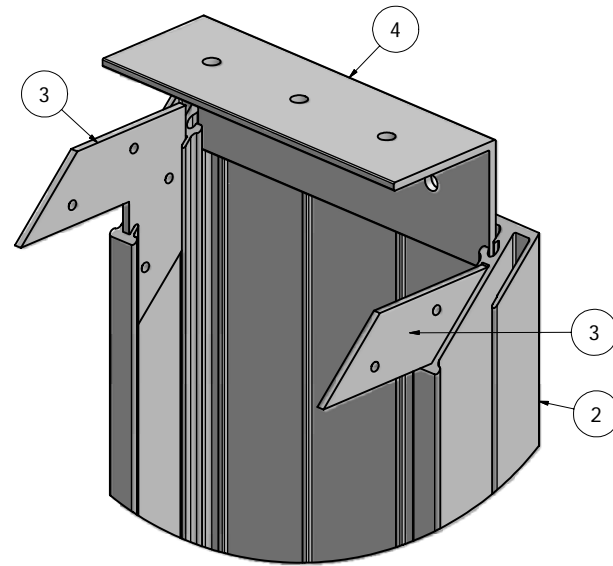
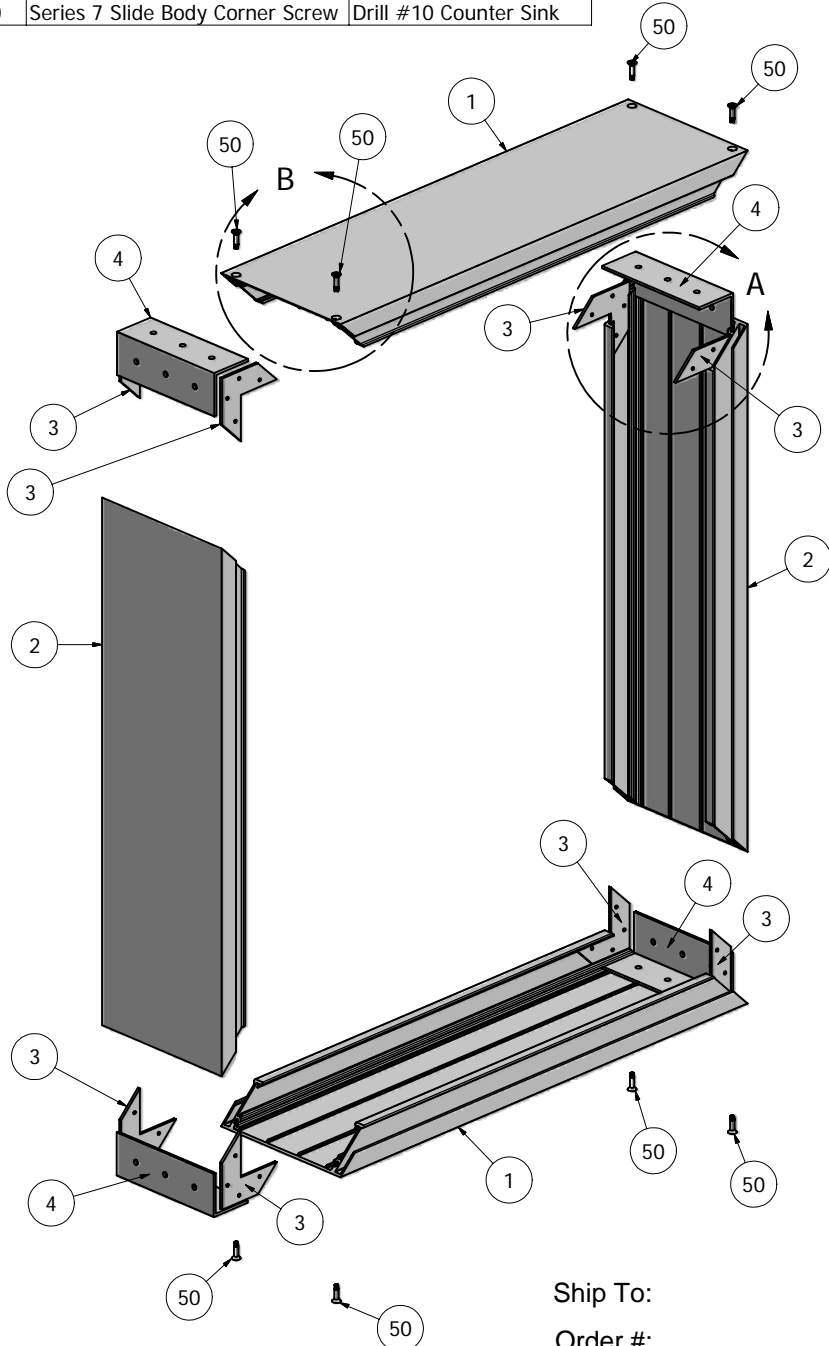

DETAIL A

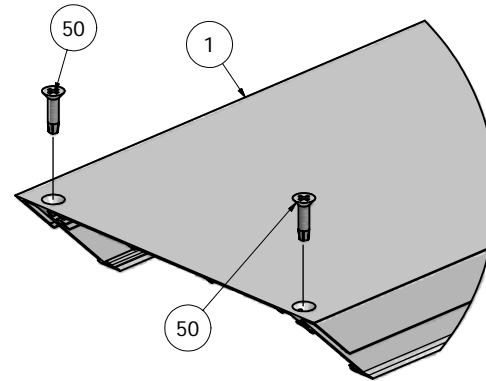

DETAIL B

**NOTE: PRE-CUT KITS ARE NOT PRE-DRILLED.**  
 (Holes shown in this drawing are for reference only.  
 Drilling of pilot holes are to be done by fabricator.)

Ship To:  
 Order #:

THIS DRAWING WAS CREATED AT NO CHARGE TO ASSIST YOU IN VISUALIZING OUR PROPOSAL. THE DRAWING HEREIN IS THE PROPERTY OF SIGNCOMP. PERMISSION TO COPY OR REVISE THIS DRAWING OR TO USE THIS DRAWING FOR PRODUCTION IS STRICTLY PROHIBITED AND CAN ONLY BE COPIED, REVISED OR USED FOR PRODUCTION WITH THE EXPRESSED WRITTEN PERMISSION OF SIGNCOMP.			
DRAWN	2/6/2009	 Series 7 Slide Body - Assembly	
CHECKED			
QA			
MFG			
APPROVED			
SIZE	C	DWG NO	K1560
SCALE			REV
			SHEET 1 OF 1

Parts List			
ITEM	PART #	DESCRIPTION	NOTES
1	K1560	Series 7 Slide Body	Assembly
2	1550	Series 7 Reveal	Attach to Slide Body
3	5220	Reveal to Body Screw	Drill 5/32" Pilot Hole in pairs 12" OC

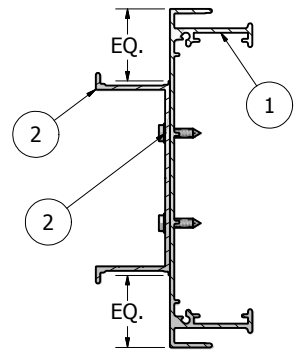
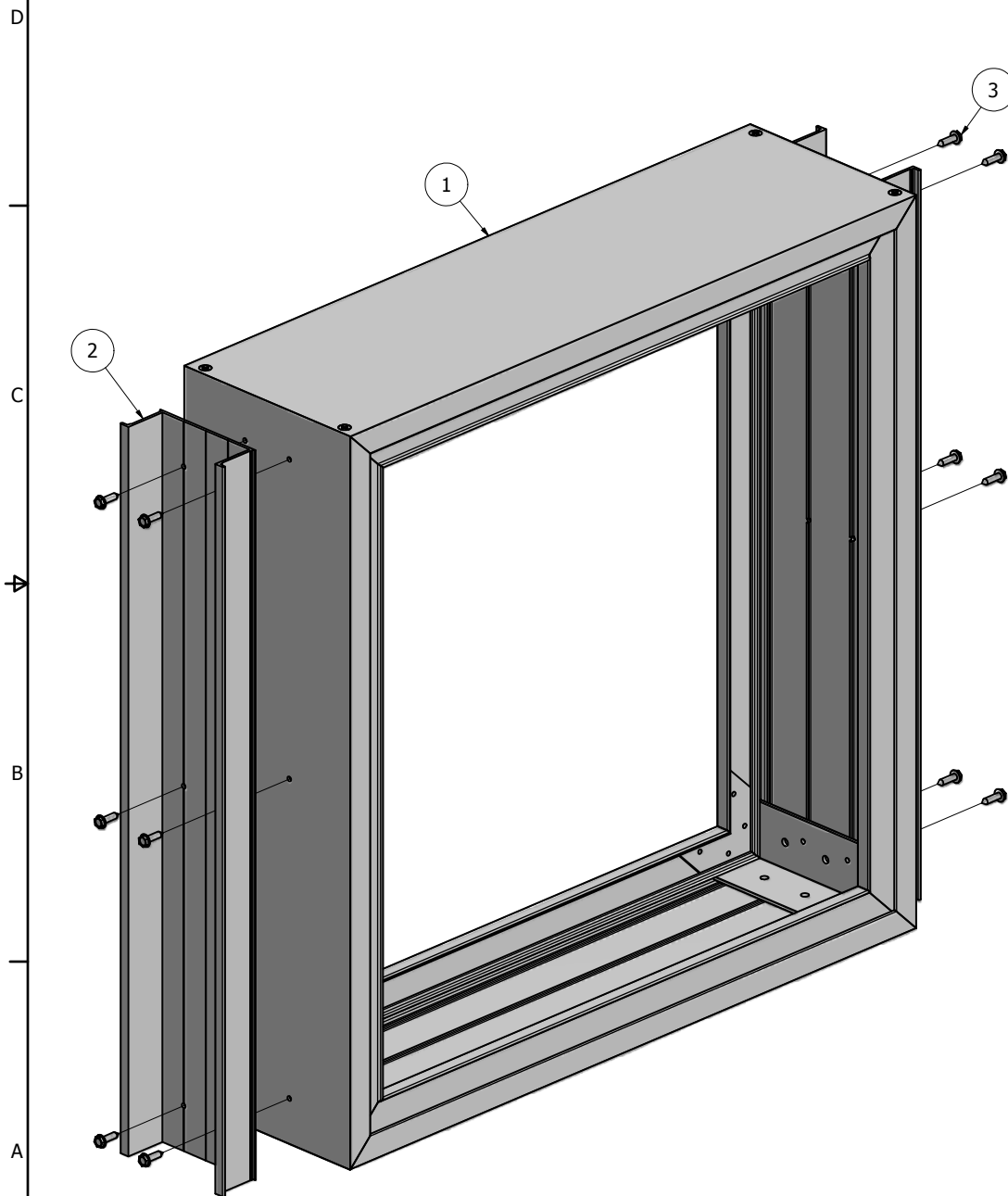

SECTION B-B

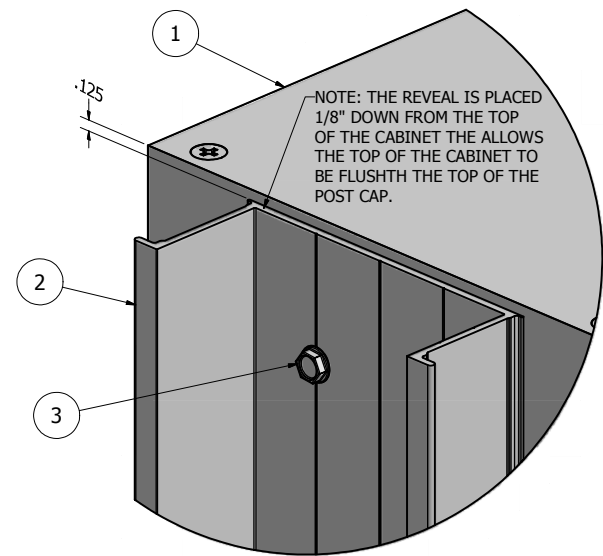
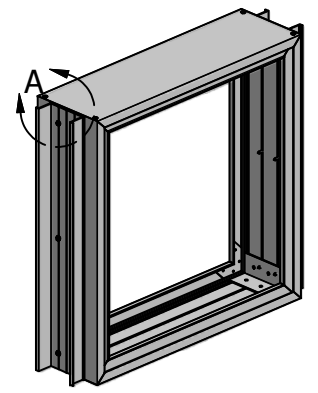

DETAIL A

**NOTE: PRE-CUT KITS ARE NOT PRE-DRILLED.**  
 (Holes shown in this drawing are for reference only.  
 Drilling of pilot holes are to be done by fabricator.)

THIS DRAWING WAS CREATED AT NO CHARGE TO ASSIST YOU IN VISUALIZING OUR PROPOSAL. THE DRAWING HEREIN IS THE PROPERTY OF SIGNCOMP. PERMISSION TO COPY OR REVISE THIS DRAWING OR TO USE THIS DRAWING FOR PRODUCTION IS STRICTLY PROHIBITED AND CAN ONLY BE COPIED, REVISED OR USED FOR PRODUCTION WITH THE EXPRESSED WRITTEN PERMISSION OF SIGNCOMP.

DRAWN	8/5/2009	<b>SignComp</b>	
Steve			
CHECKED		TITLE	
QA		K1560 with Series 7 Reveal - Reveal Attachment Detail	
MFG		SIZE	DWG NO
APPROVED		C	K1560/50
		SCALE	REV
			SHEET 1 OF 1

Ship To:  
 Order #:

Parts List			
ITEM	PART #	DESCRIPTION	NOTES
1	1530	Series 7 Triangular Post	
2	1550	Series 7 Reveal	Tack weld or mechanically fasten to post

Ship To:  
Order #:

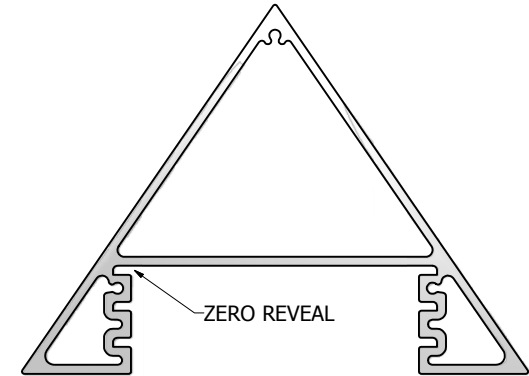
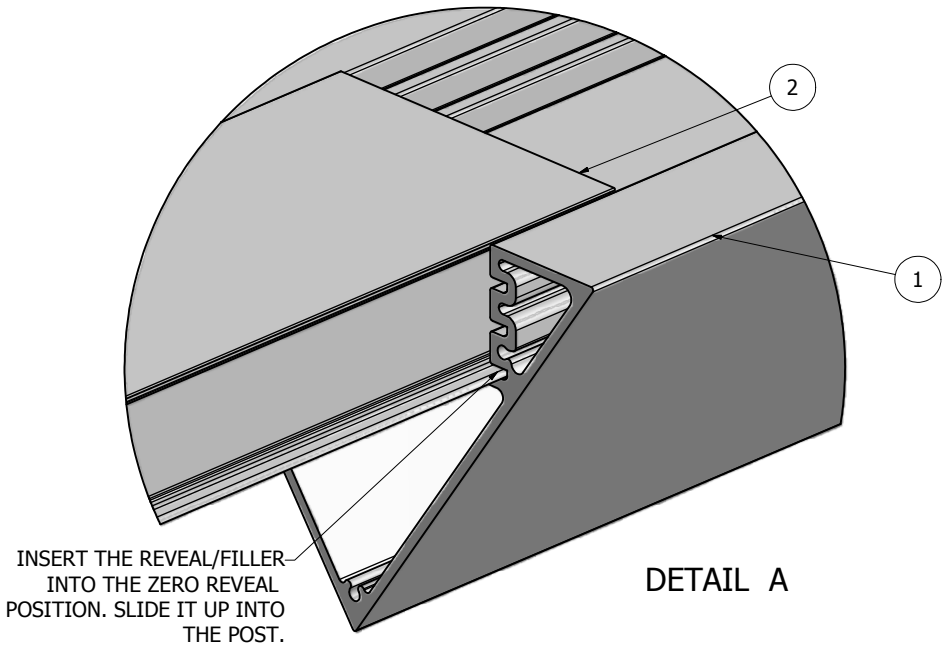
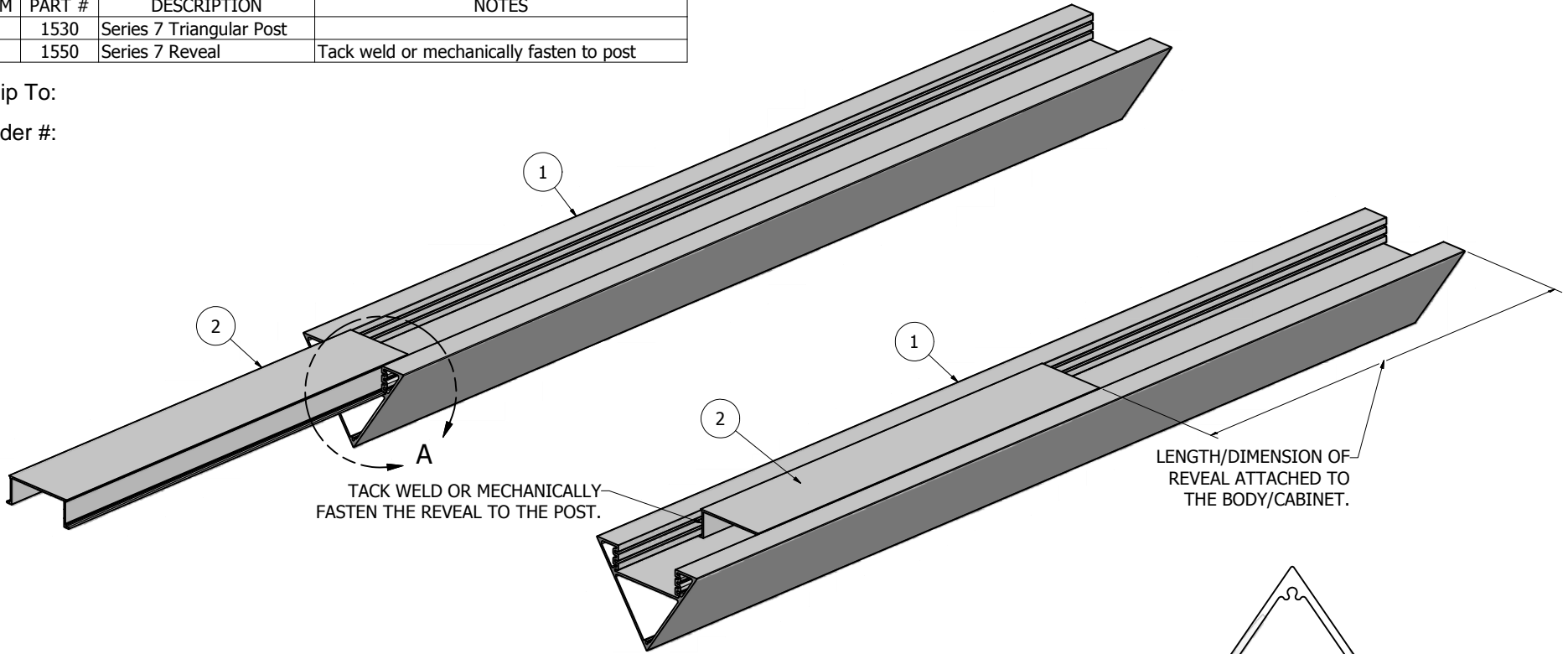

**NOTE: PRE-CUT KITS ARE NOT PRE-DRILLED.**  
(Holes shown in this drawing are for reference only.  
Drilling of pilot holes are to be done by fabricator.)

THIS DRAWING WAS CREATED AT NO CHARGE TO ASSIST YOU IN VISUALIZING OUR PROPOSAL. THE DRAWING HEREIN IS THE PROPERTY OF SIGNCOMP. PERMISSION TO COPY OR REVISE THIS DRAWING OR TO USE THIS DRAWING FOR PRODUCTION IS STRICTLY PROHIBITED AND CAN ONLY BE COPIED, REVISED OR USED FOR PRODUCTION WITH THE EXPRESSED WRITTEN PERMISSION OF SIGNCOMP.

DRAWN	8/6/2009	<b>SignComp</b>	
CHECKED			
QA		TITLE	
MFG		Series 7 Triangular Post with Reveal/Filler Assembly	
APPROVED		SIZE	DWG NO
		C	K1530-50
		SCALE	SHEET 1 OF 1