

Parts List			
ITEM	PART #	DESCRIPTION	NOTES
1	K1100	Series 2 Square Post - Assembly	
41	5040	Post Cap Screws	2 - #10 x 1/2" counter sunk phillips head screws per post
2	Post Cap	Series 2 Square Post Cap	Zero Reveal Part #5260, 3/8" Reveal Part #5261, 3/4" Reveal Part #5262
3	K1420-12	Series CB 2" Copy Bar - Assembly	Slide copy bar into post
4	K1430-13	Series CB 3" Copy Bar - Assembly	Slide copy bar into post
5	K1440-14	Series CB 4" Copy Bar - Assembly	Slide copy bar into post
6	K1450-15	Series CB 5" Copy Bar - Assembly	Slide copy bar into post
7	K1460-16	Series CB 6" Copy Bar - Assembly	Slide copy bar into post

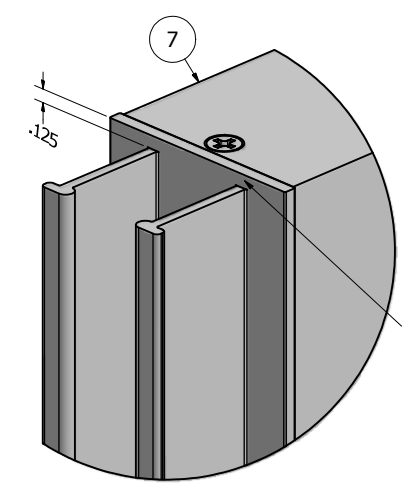

DETAIL A

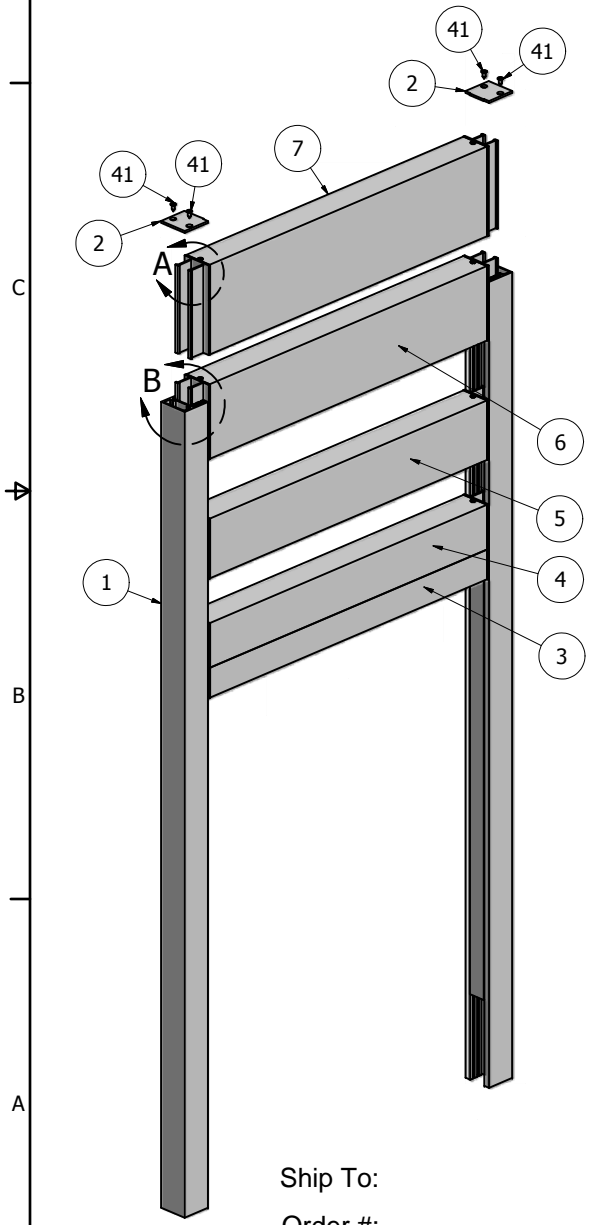
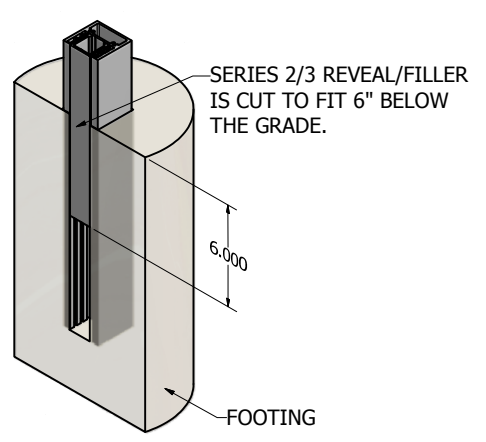

SERIES 2/3 REVEAL/FILLER IS CUT TO FIT 6" BELOW THE GRADE.

FOOTING

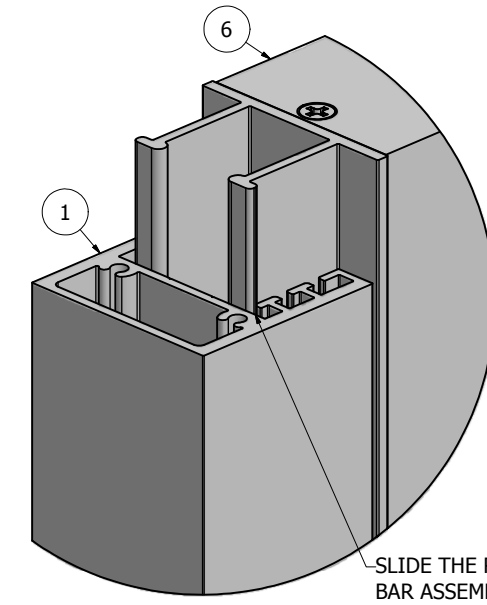

DETAIL B

SLIDE THE REVEAL/COPY BAR ASSEMBLY INTO THE DESIRED REVEAL POSITION.

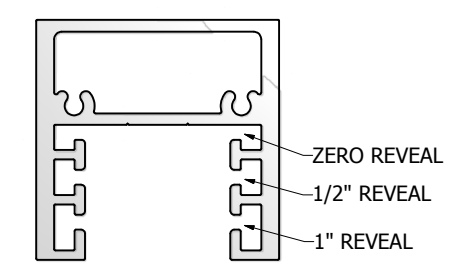

NOTE: PRE-CUT KITS ARE NOT PRE-DRILLED.
 (Holes shown in this drawing are for reference only. Drilling of pilot holes are to be done by fabricator.)

THIS DRAWING WAS CREATED AT NO CHARGE TO ASSIST YOU IN VISUALIZING OUR PROPOSAL. THE DRAWING HEREIN IS THE PROPERTY OF SIGNCOMP. PERMISSION TO COPY OR REVISE THIS DRAWING OR TO USE THIS DRAWING FOR PRODUCTION IS STRICTLY PROHIBITED AND CAN ONLY BE COPIED, REVISED OR USED FOR PRODUCTION WITH THE EXPRESSED WRITTEN PERMISSION OF SIGNCOMP.

DRAWN	Steve	5/26/2010	SignComp		
CHECKED					
QA			TITLE		
MFG			Series CB - Series 2 Square Post - Assembly		
APPROVED			SIZE	DWG NO	REV
			C	K1400	
			SCALE	SHEET 1 OF 1	

Ship To:
 Order #:

Parts List			
ITEM	PART #	DESCRIPTION	NOTES
1	1420	Series CB 2" Copy Bar	
2	1412	2"Series CB Reveal	Reveal required each end
58	5168	Reveal to Copy Bar Screw	4 - #8 x 1/2" counter sunk phillips head screws - 2 each end

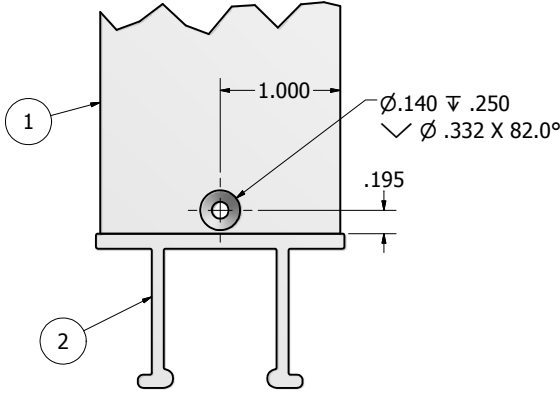
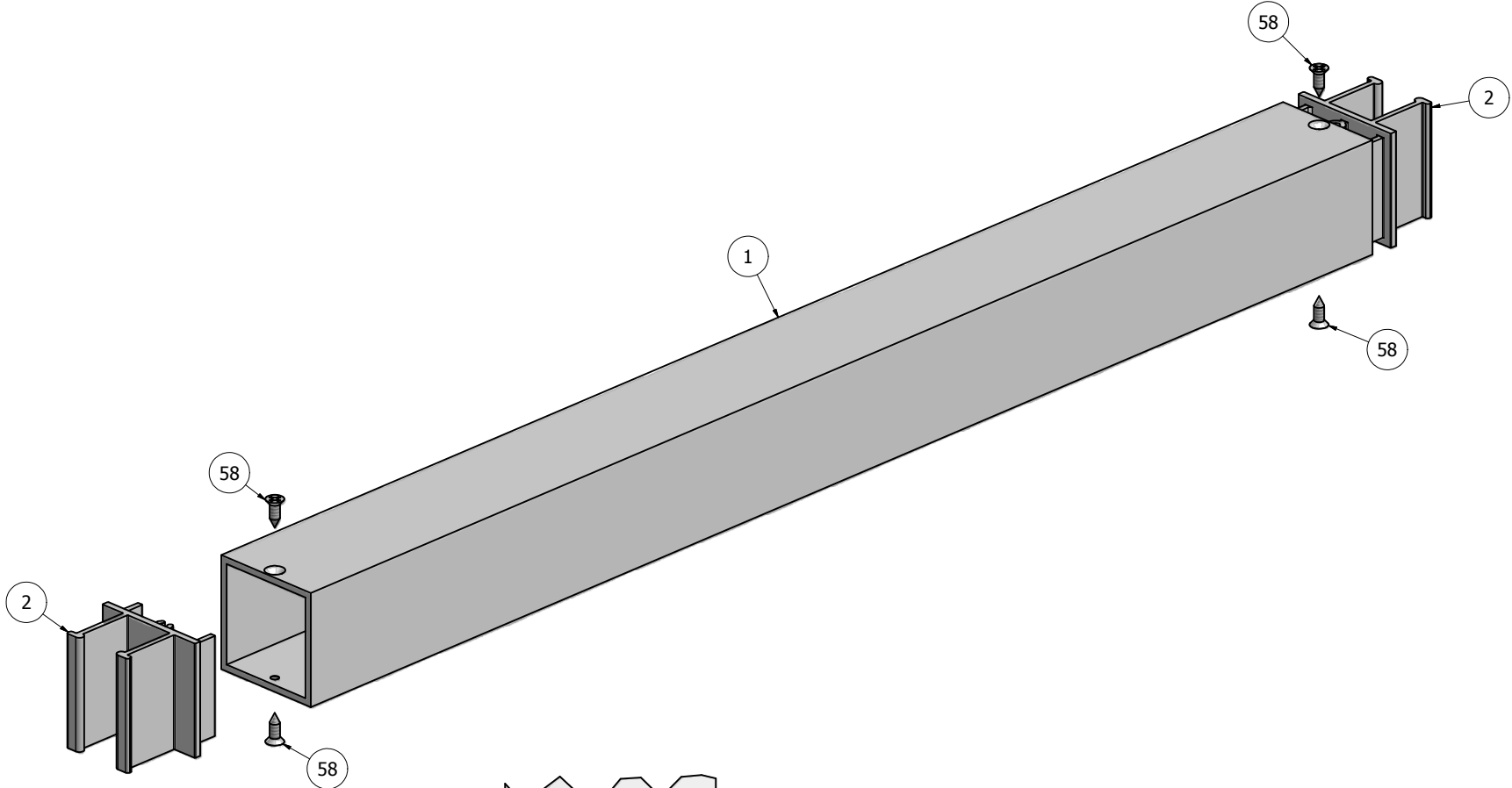

NOTE: PRE-CUT KITS ARE NOT PRE-DRILLED.
 (Holes shown in this drawing are for reference only.
 Drilling of pilot holes are to be done by fabricator.)

THIS DRAWING WAS CREATED AT NO CHARGE TO ASSIST YOU IN VISUALIZING OUR PROPOSAL. THE DRAWING HEREIN IS THE PROPERTY OF SIGNCOMP. PERMISSION TO COPY OR REVISE THIS DRAWING OR TO USE THIS DRAWING FOR PRODUCTION IS STRICTLY PROHIBITED AND CAN ONLY BE COPIED, REVISED OR USED FOR PRODUCTION WITH THE EXPRESSED WRITTEN PERMISSION OF SIGNCOMP.

DRAWN	Steve	5/25/2010	SignComp	
CHECKED				
QA			TITLE	
MFG			Series CB - 2" Copy Bar - Series CB 2" Reveal - Assembly	
APPROVED			SIZE	DWG NO
			C	K1420-12
			SCALE	SHEET 1 OF 1

Ship To:
 Order #:

Parts List			
ITEM	PART #	DESCRIPTION	NOTES
1	1430	Series CB 3" Copy Bar	
2	1413	3" Series CB Reveal	Reveal required at each end
58	5168	Reveal to Copy Bar Screw	4 - #8 x 1/2" counter sunk phillips head screws - 2 each end

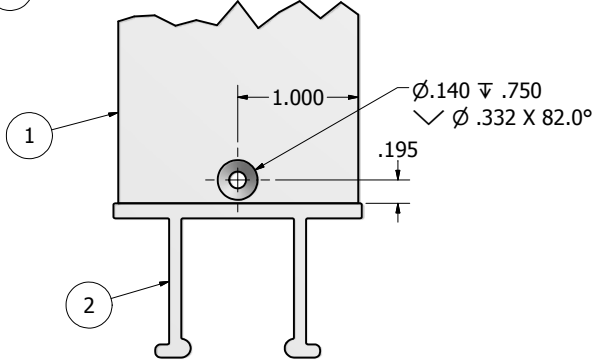
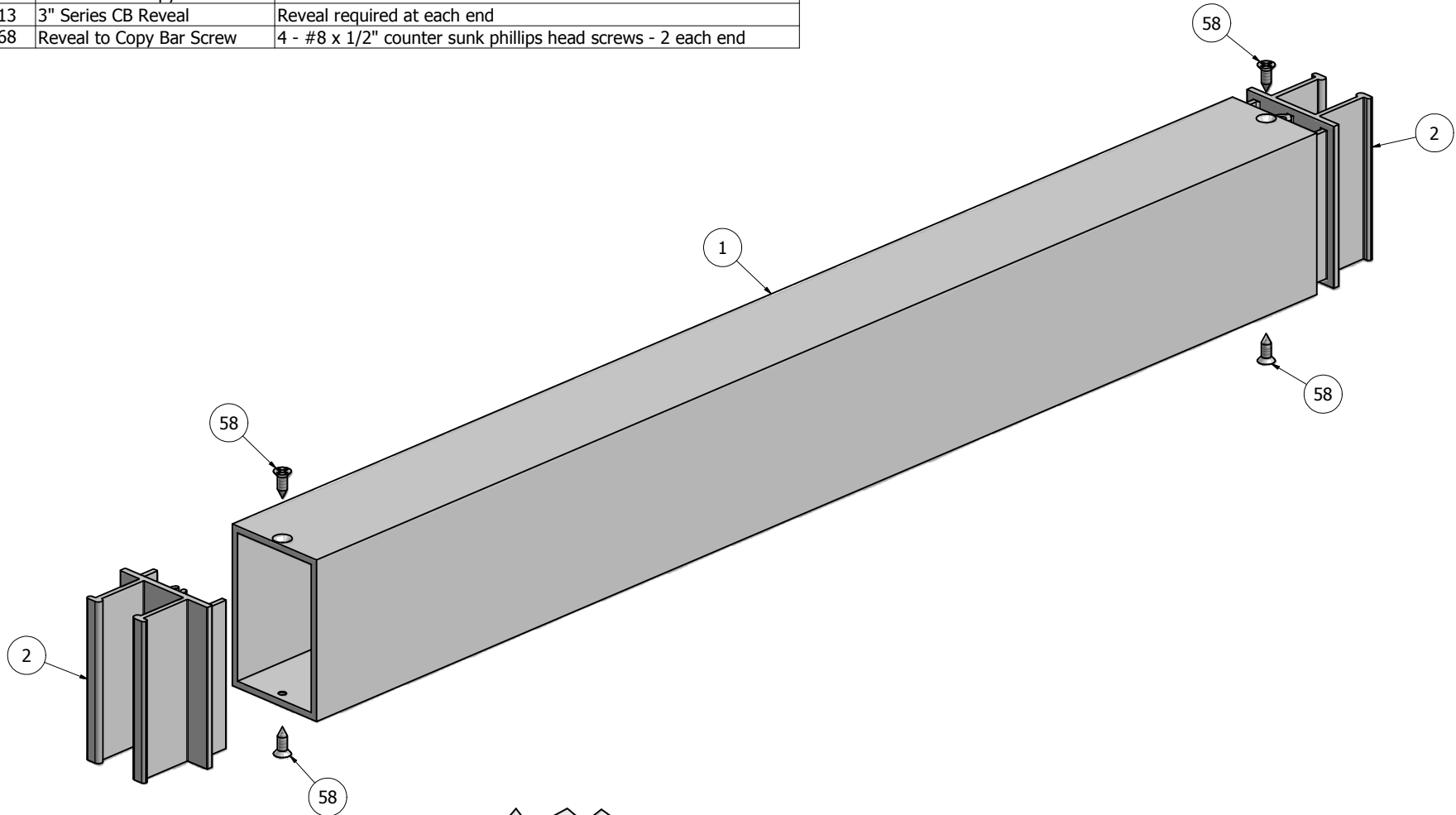

NOTE: PRE-CUT KITS ARE NOT PRE-DRILLED.

(Holes shown in this drawing are for reference only.
Drilling of pilot holes are to be done by fabricator.)

THIS DRAWING WAS CREATED AT NO CHARGE TO ASSIST YOU IN VISUALIZING OUR PROPOSAL. THE DRAWING HEREIN IS THE PROPERTY OF SIGNCOMP. PERMISSION TO COPY OR REVISE THIS DRAWING OR TO USE THIS DRAWING FOR PRODUCTION IS STRICTLY PROHIBITED AND CAN ONLY BE COPIED, REVISED OR USED FOR PRODUCTION WITH THE EXPRESSED WRITTEN PERMISSION OF SIGNCOMP.

DRAWN	Steve	5/25/2010	SignComp		
CHECKED					
QA			TITLE		
MFG			Series CB - 3" Copy Bar - Series CB 3" Reveal - Assembly		
APPROVED			SIZE	DWG NO	REV
			C	K1430-13	
			SCALE	SHEET 1 OF 1	

Ship To:

Order #:

Parts List			
ITEM	PART #	DESCRIPTION	NOTES
1	1440	Series CB 4" Copy Bar	
2	1414	4" Series CB Reveal	Reveal required each end
58	5168	Reveal to Copy Bar Screw	4 - #8 x 1/2" counter sunk phillips head screws - 2 each end

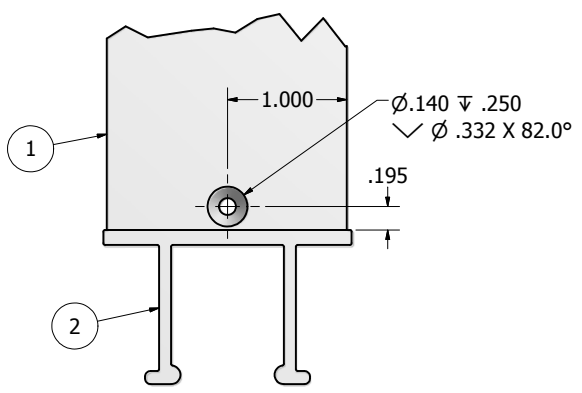
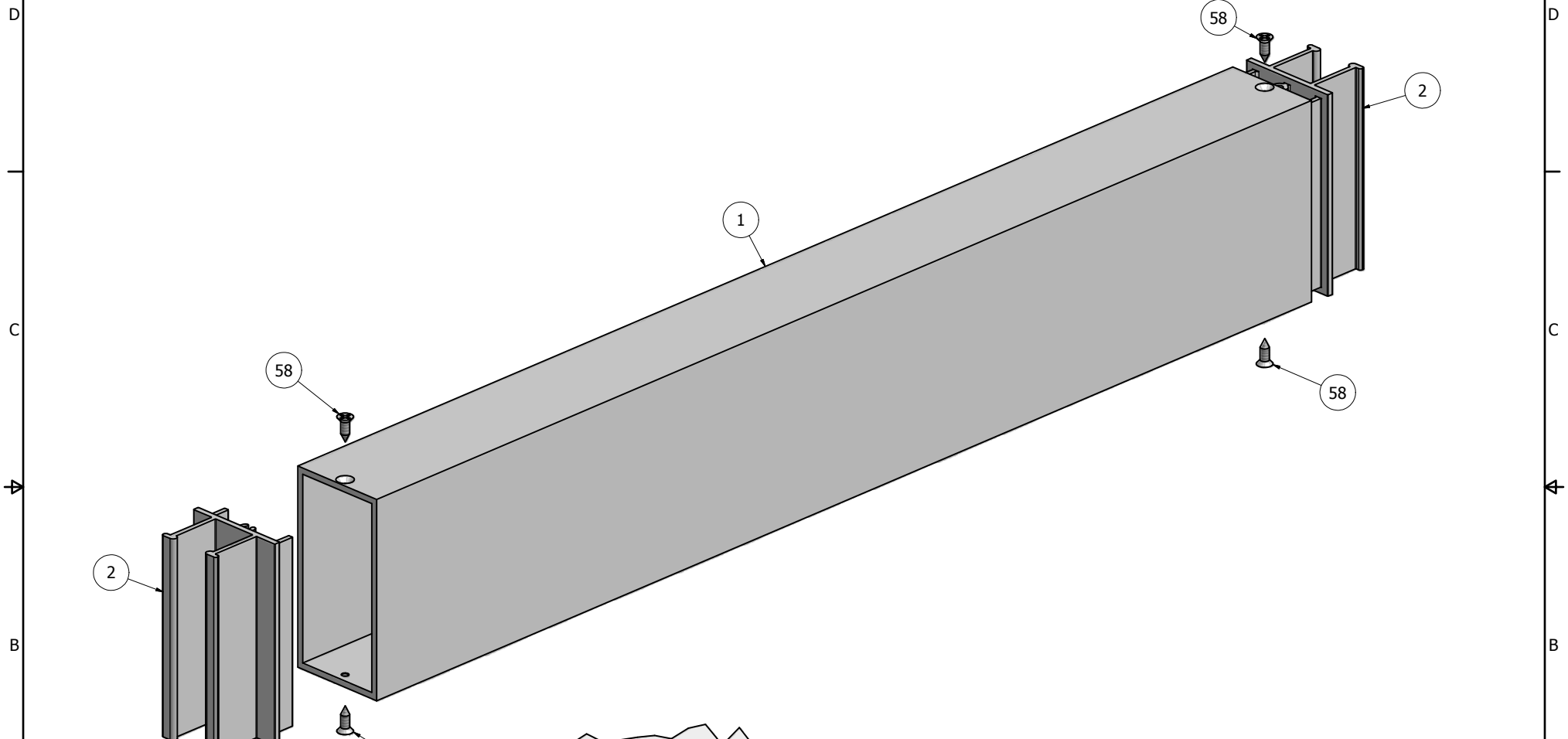

NOTE: PRE-CUT KITS ARE NOT PRE-DRILLED.
 (Holes shown in this drawing are for reference only.
 Drilling of pilot holes are to be done by fabricator.)

THIS DRAWING WAS CREATED AT NO CHARGE TO ASSIST YOU IN VISUALIZING OUR PROPOSAL. THE DRAWING HEREIN IS THE PROPERTY OF SIGNCOMP. PERMISSION TO COPY OR REVISE THIS DRAWING OR TO USE THIS DRAWING FOR PRODUCTION IS STRICTLY PROHIBITED AND CAN ONLY BE COPIED, REVISED OR USED FOR PRODUCTION WITH THE EXPRESSED WRITTEN PERMISSION OF SIGNCOMP.

DRAWN	5/25/2010	SignComp	
CHECKED			
QA		TITLE	
MFG		Series CB 4" Copy Bar - Series CB 4" Reveal - Assembly	
APPROVED		SIZE	DWG NO
		C	K1440-14
		SCALE	SHEET 1 OF 1

Ship To:
 Order #:

Parts List			
ITEM	PART #	DESCRIPTION	NOTES
1	1450	Series CB 5" Copy Bar	
2	1415I	5" Series CB Reveal	Reveal required each end
58	5168	Reveal to Copy Bar Screw	4 - #8 x 1/2" counter sunk phillips head screws - 2 each end

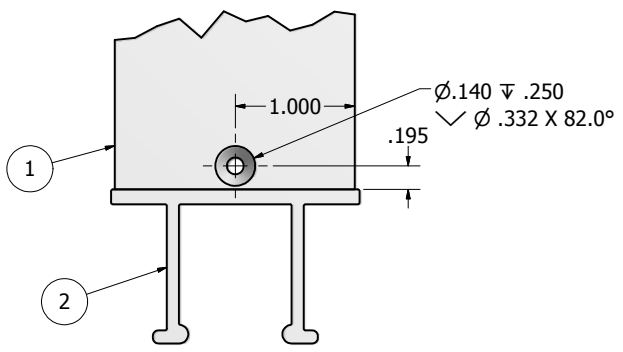
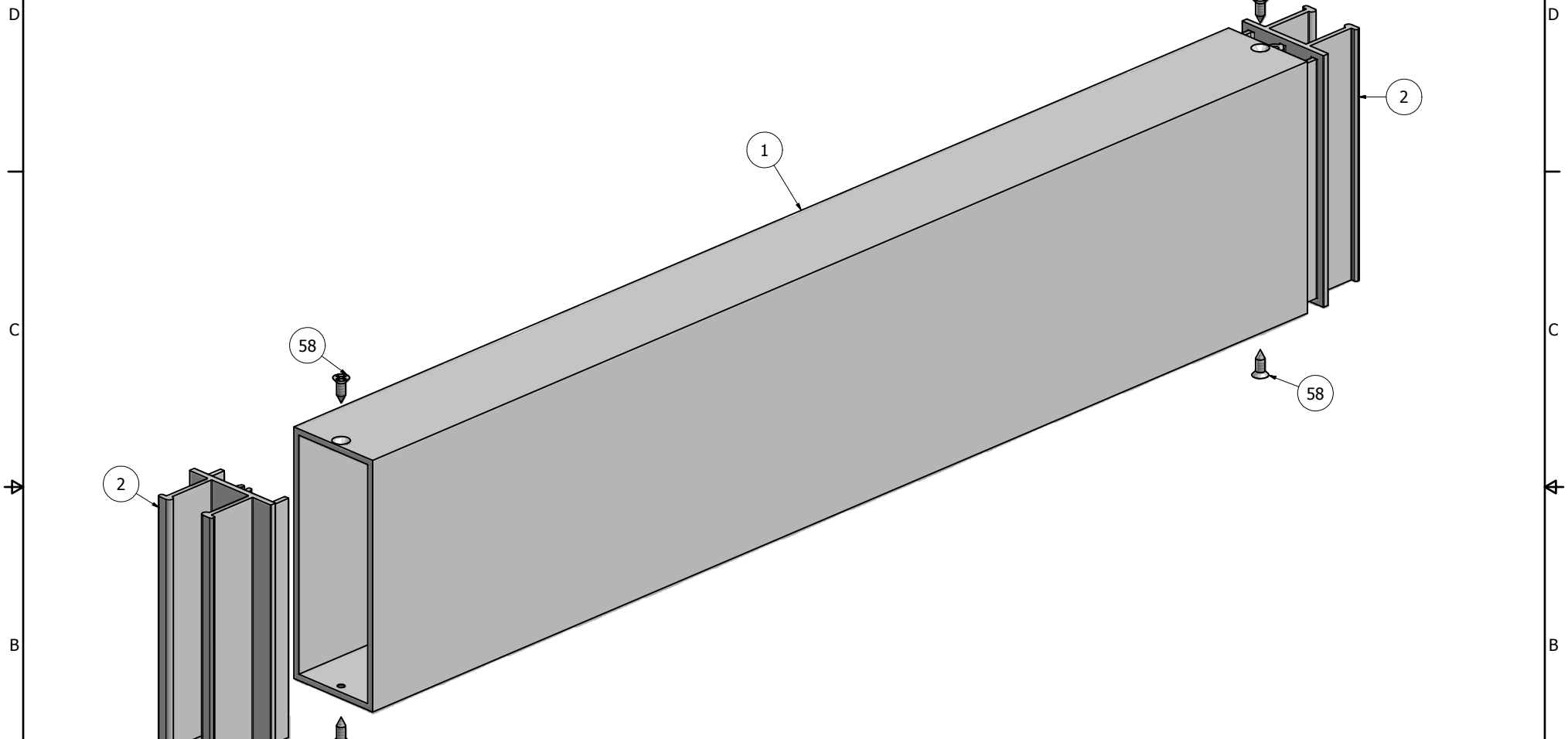

NOTE: PRE-CUT KITS ARE NOT PRE-DRILLED.
 (Holes shown in this drawing are for reference only.
 Drilling of pilot holes are to be done by fabricator.)

THIS DRAWING WAS CREATED AT NO CHARGE TO ASSIST YOU IN VISUALIZING OUR PROPOSAL. THE DRAWING HEREIN IS THE PROPERTY OF SIGNCOMP. PERMISSION TO COPY OR REVISE THIS DRAWING OR TO USE THIS DRAWING FOR PRODUCTION IS STRICTLY PROHIBITED AND CAN ONLY BE COPIED, REVISED OR USED FOR PRODUCTION WITH THE EXPRESSED WRITTEN PERMISSION OF SIGNCOMP.

DRAWN	Steve	5/25/2010	SignComp		
CHECKED					
QA			TITLE		
MFG			Series CB 5" Copy Bar - Series CB 2" Reveal - Assembly		
APPROVED			SIZE	DWG NO	REV
			C	K1450-15	
			SCALE	SHEET 1 OF 1	

Ship To:
 Order #:

Parts List			
ITEM	PART #	DESCRIPTION	NOTES
1	1460	Series CB 6" Copy Bar	
2	1416	6" Series CB Reveal	Reveal required each end
58	5168	Reveal to Copy Bar Screw	4 - #8 x 1/2" counter sunk phillips head screws - 2 each end

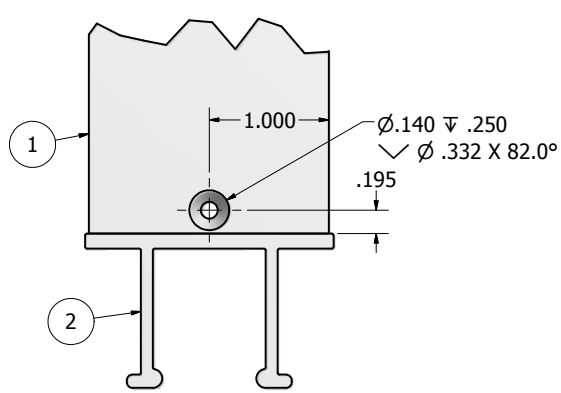
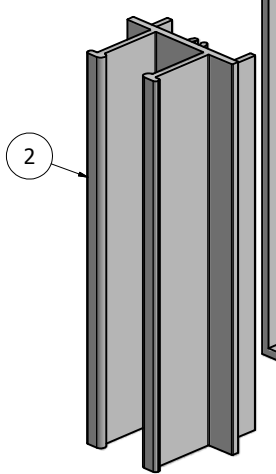
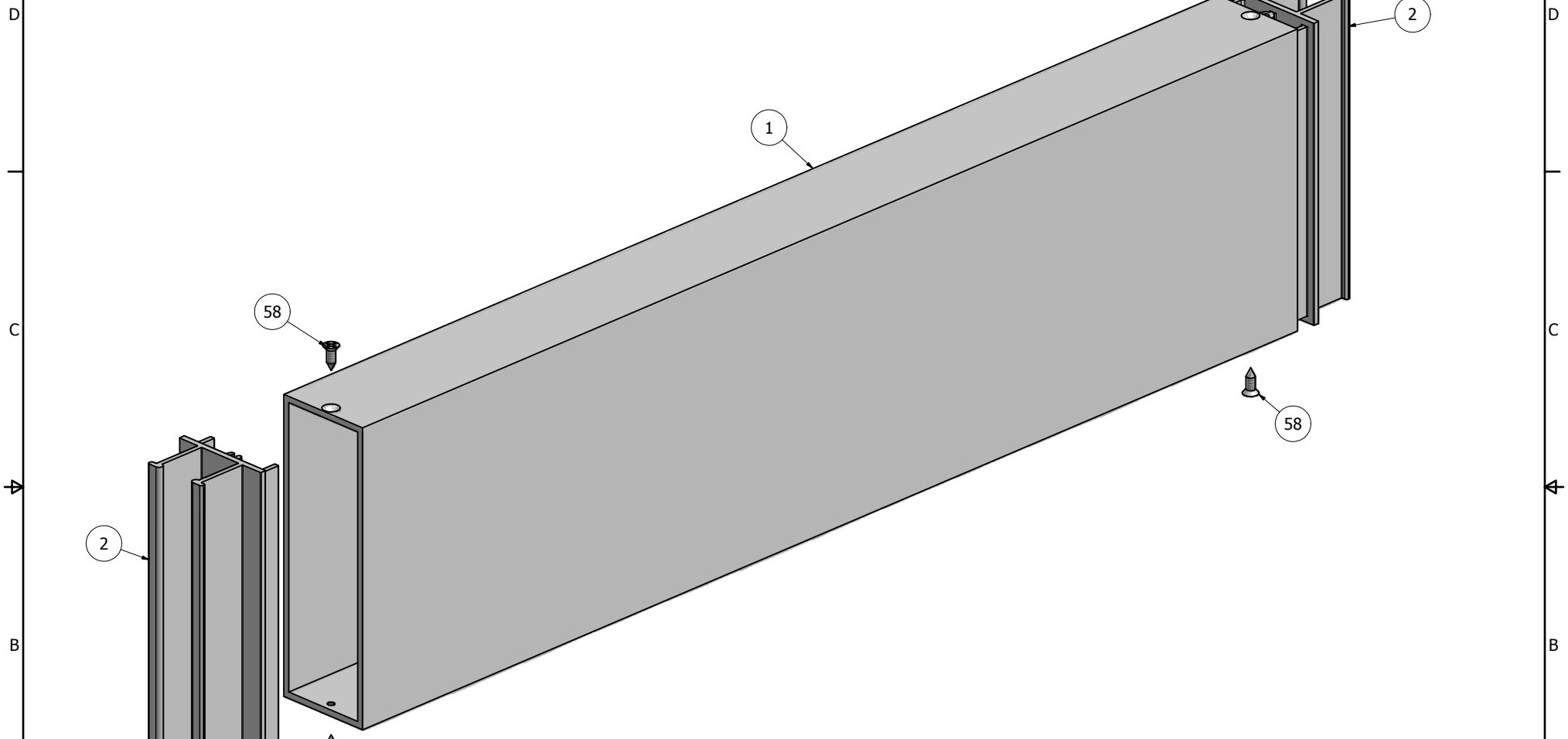

NOTE: PRE-CUT KITS ARE NOT PRE-DRILLED.
 (Holes shown in this drawing are for reference only.
 Drilling of pilot holes are to be done by fabricator.)

THIS DRAWING WAS CREATED AT NO CHARGE TO ASSIST YOU IN VISUALIZING OUR PROPOSAL. THE DRAWING HEREIN IS THE PROPERTY OF SIGNCOMP. PERMISSION TO COPY OR REVISE THIS DRAWING OR TO USE THIS DRAWING FOR PRODUCTION IS STRICTLY PROHIBITED AND CAN ONLY BE COPIED, REVISED OR USED FOR PRODUCTION WITH THE EXPRESSED WRITTEN PERMISSION OF SIGNCOMP.

DRAWN	5/26/2010	SignComp	
CHECKED			
QA		TITLE	
MFG		Series CB 6" Copy Bar - Series CB 6" Reveal - Assembly	
APPROVED		SIZE	DWG NO
		C	K1460-16
		SCALE	SHEET 1 OF 1

Ship To:
 Order #:

Parts List			
ITEM	PART	DESCRIPTION	NOTES
1	1100	Series 2 Square Post	
2	1200	Series 2/3 Reveal (Filler)	Tack weld or mechanically fasten to post

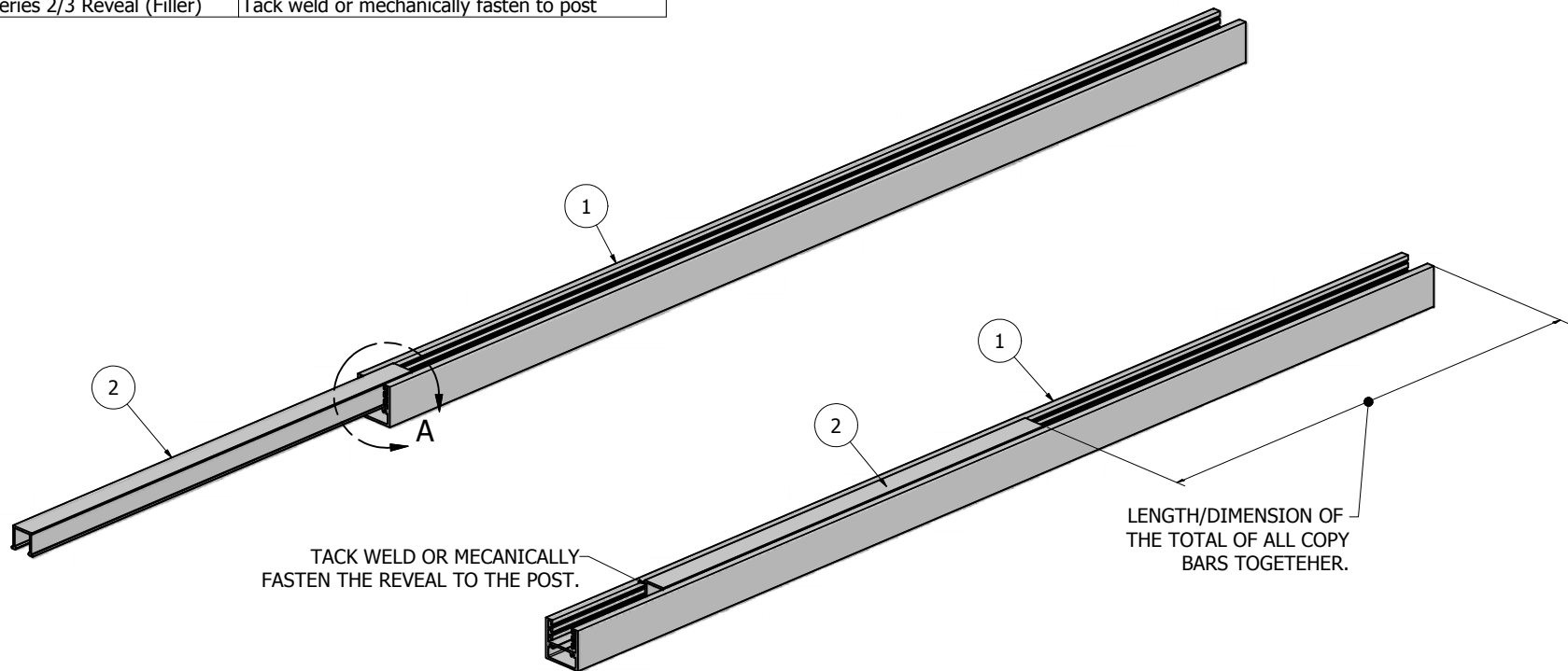

TACK WELD OR MECANICALLY FASTEN THE REVEAL TO THE POST.

LENGTH/DIMENSION OF THE TOTAL OF ALL COPY BARS TOGETHEER.

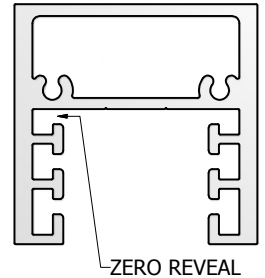

NOTE: PRE-CUT KITS ARE NOT PRE-DRILLED.
 (Holes shown in this drawing are for reference only.
 Drilling of pilot holes are to be done by fabricator.)

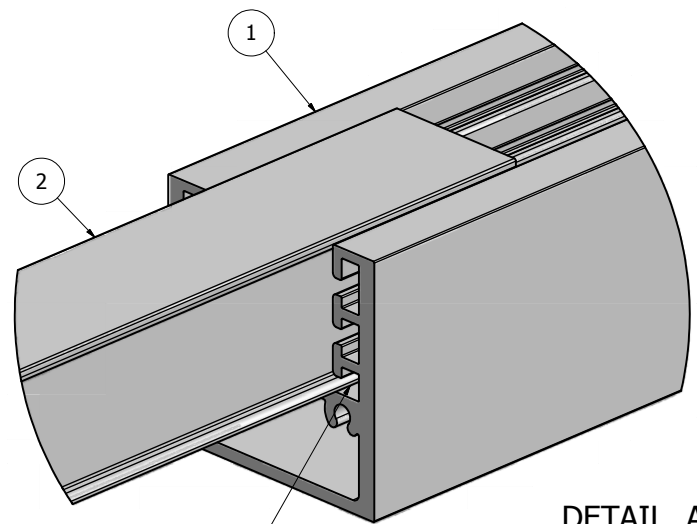

INSERT THE REVEAL/FILLER INTO THE ZERO REVEAL POSTION. SLIDED IT UP INTO THE POST.

DETAIL A

Ship To:
 Order #:

THIS DRAWING WAS CREATED AT NO CHARGE TO ASSIST YOU IN VISUALIZING OUR PROPOSAL. THE DRAWING HEREIN IS THE PROPERTY OF SIGNCOMP. PERMISSION TO COPY OR REVISE THIS DRAWING OR TO USE THIS DRAWING FOR PRODUCTION IS STRICTLY PROHIBITED AND CAN ONLY BE COPIED, REVISED OR USED FOR PRODUCTION WITH THE EXPRESSED WRITTEN PERMISSION OF SIGNCOMP.

DRAWN	3/31/2010	SignComp	
CHECKED			
QA		TITLE	
MFG		Series 2 Square Post - Series 2/3 Reveal Assembly	
APPROVED		SIZE	DWG NO
		C	K1100-00
		SCALE	SHEET 1 OF 1