

Parts List			
ITEM	PART #	DESCRIPTION	NOTES
1	1100	Series 2 Square Post	
2	1200	Series 2/3 Reveal	Attached to body
3	Post Cap	Series 2 Square Post Cap	Zero Reveal Part #5260, 3/8" Reveal Part #5261, 3/4" Reveal Part #5262
41	5040	Cap Screw	2 - #10x 1/2" counter sunk phillips head screws
5	K1110/00	Series 2 Slide Body - Assembly	Slide assembly into post

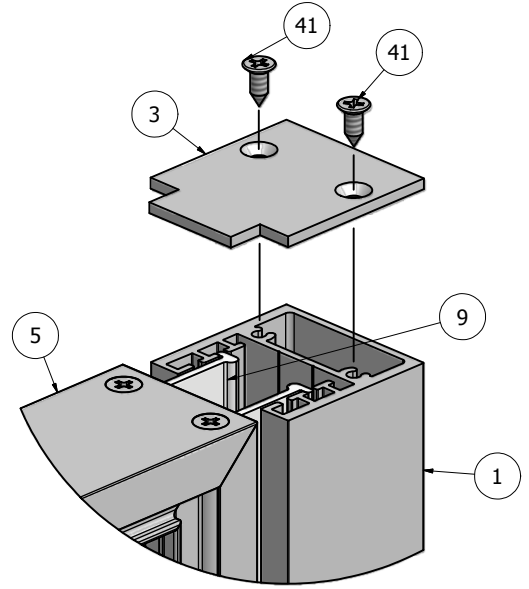

DETAIL A

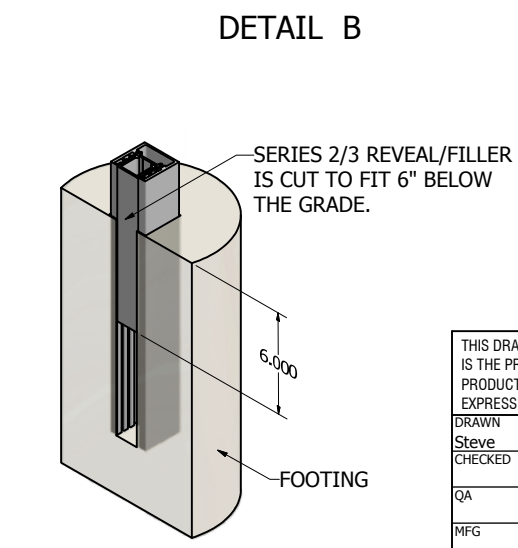
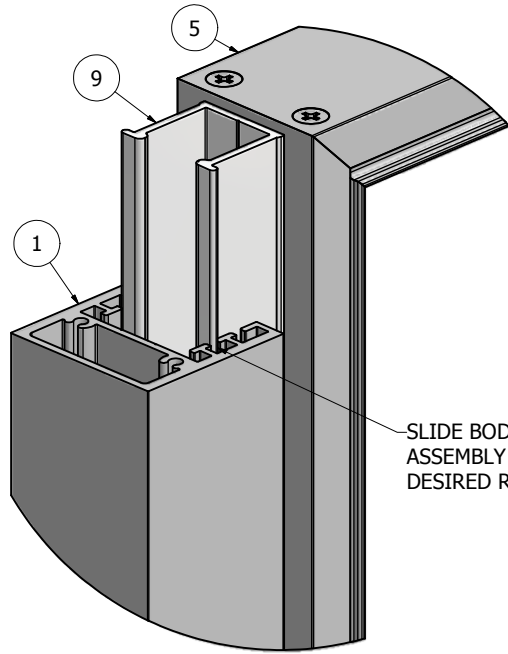
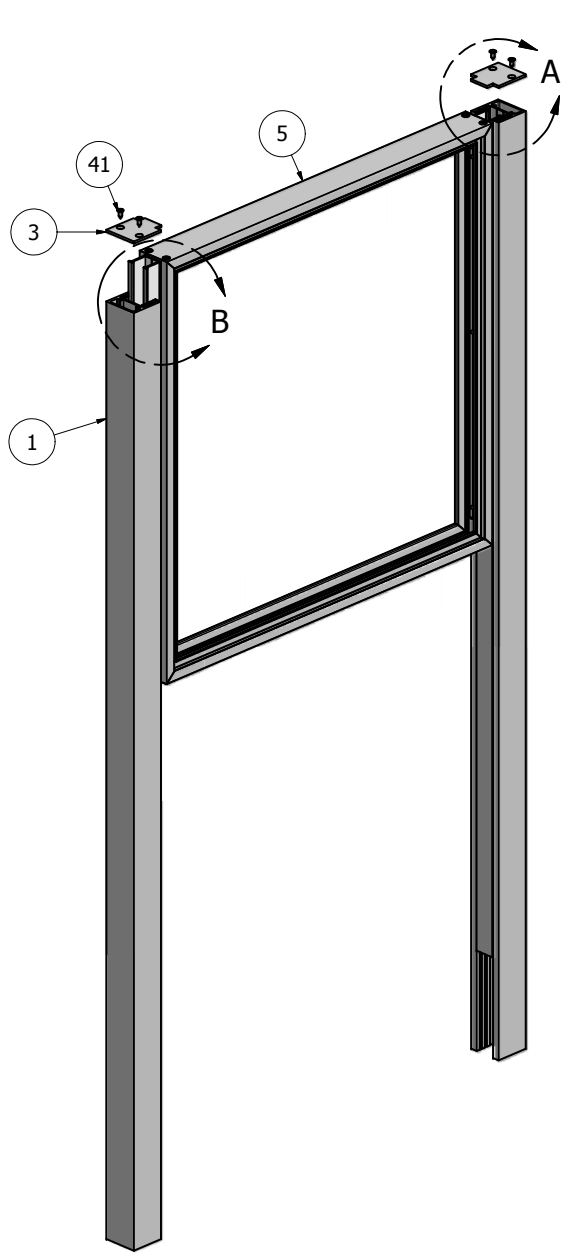
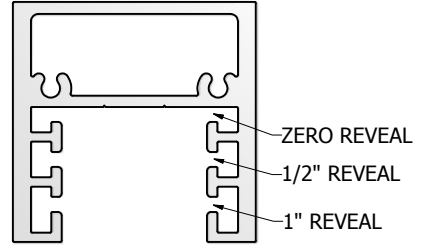

SLIDE BODY/CABINET ASSEMBLY INTO THE DESIRED REVEAL POSITION.

NOTE: PRE-CUT KITS ARE NOT PRE-DRILLED.
 (Holes shown in this drawing are for reference only.
 Drilling of pilot holes are to be done by fabricator.)

THIS DRAWING WAS CREATED AT NO CHARGE TO ASSIST YOU IN VISUALIZING OUR PROPOSAL. THE DRAWING HEREIN IS THE PROPERTY OF SIGNCOMP. PERMISSION TO COPY OR REVISE THIS DRAWING OR TO USE THIS DRAWING FOR PRODUCTION IS STRICTLY PROHIBITED AND CAN ONLY BE COPIED, REVISED OR USED FOR PRODUCTION WITH THE EXPRESSED WRITTEN PERMISSION OF SIGNCOMP.

DRAWN	Steve	4/1/2010	SignComp	
CHECKED				
QA				
MFG				
APPROVED			TITLE	Series 2 Slide Body - Series 2 Square Post - Assembly
			SIZE	C
			DWG NO	K1100-10-00
			SCALE	
			REV	
			SHEET 1 OF 1	

Ship To:
 Order #:

Parts List			
ITEM	PART #	DESCRIPTION	NOTES
1	K1110	Series 2 Slide Body	Assembly
2	1200	Series 2/3 Reveal	Attach to Slide Body
42	5220	Reveal to Body Screw	Drill 5/32" pilot hole 12" OC

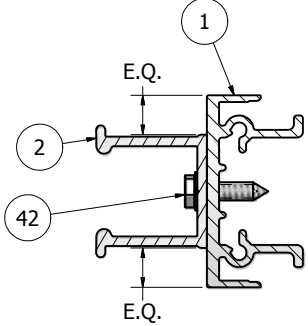
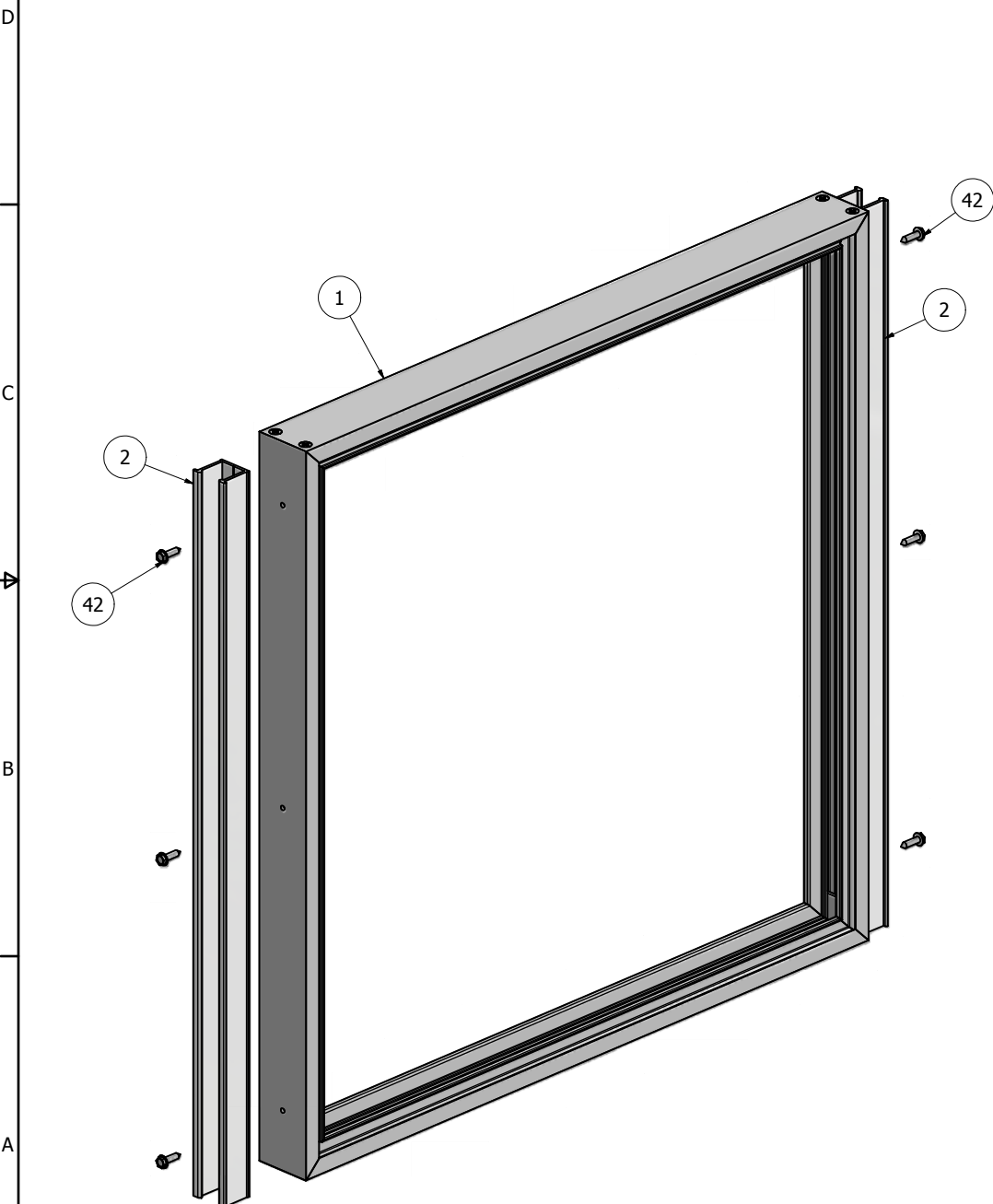

SECTION A-A

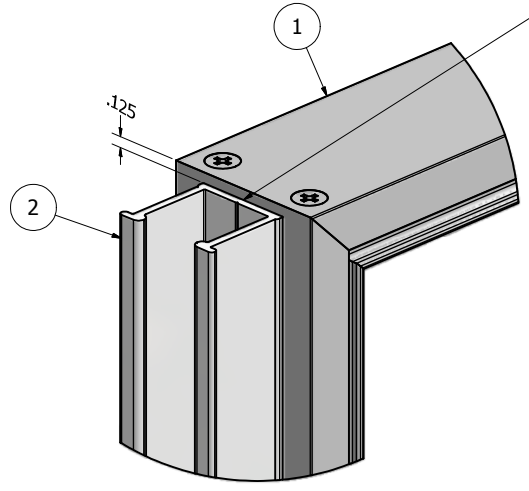
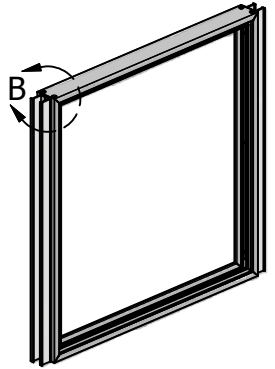

DETAIL B

NOTE: THE REVEAL IS PLACED 1/8" DOWN FROM THE TOP OF THE CABINET THE ALLOWS THE TOP OF THE CABINET TO BE FLUSH WITH THE TOP OF THE POST CAP.

NOTE: PRE-CUT KITS ARE NOT PRE-DRILLED.

(Holes shown in this drawing are for reference only. Drilling of pilot holes are to be done by fabricator.)

THIS DRAWING WAS CREATED AT NO CHARGE TO ASSIST YOU IN VISUALIZING OUR PROPOSAL. THE DRAWING HEREIN IS THE PROPERTY OF SIGNCOMP. PERMISSION TO COPY OR REVISE THIS DRAWING OR TO USE THIS DRAWING FOR PRODUCTION IS STRICTLY PROHIBITED AND CAN ONLY BE COPIED, REVISED OR USED FOR PRODUCTION WITH THE EXPRESSED WRITTEN PERMISSION OF SIGNCOMP.

DRAWN	3/31/2010
CHECKED	
QA	
MFG	
APPROVED	

SignComp		
TITLE Series 2 Slide Body with series 2/3 Reveal - Assembly		
SIZE C	DWG NO K1110/00	REV
SCALE	SHEET 1 OF 1	

Ship To:
Order #:

Parts List			
ITEM	PART #	DESCRIPTION	NOTES
1	1110	Series 2 Slide Body	Top & Bottom
2	1110	Series 2 Slide Body	Sides
3	5330	Series 2 Slide Body Corner Angle	
48	5240	Slide Body Screw	Drill #10 Counter Sink

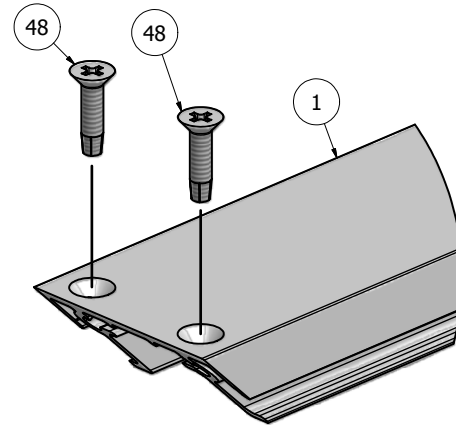
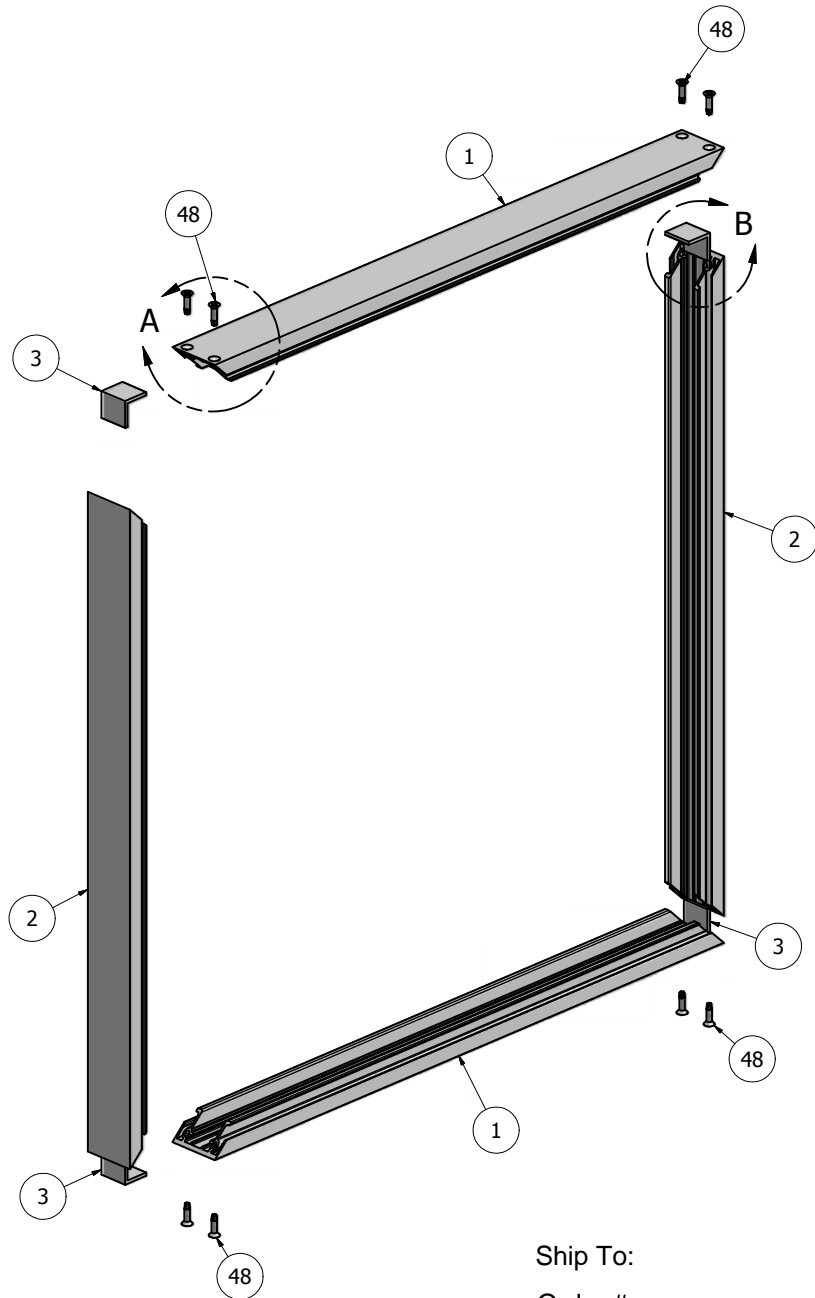

DETAIL A

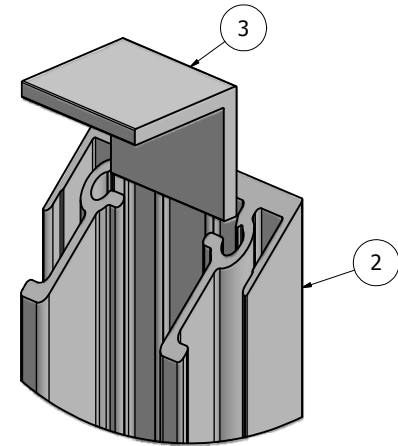

DETAIL B

NOTE: PRE-CUT KITS ARE NOT PRE-DRILLED.

(Holes shown in this drawing are for reference only.
Drilling of pilot holes are to be done by fabricator.)

THIS DRAWING WAS CREATED AT NO CHARGE TO ASSIST YOU IN VISUALIZING OUR PROPOSAL. THE DRAWING HEREIN IS THE PROPERTY OF SIGNCOMP. PERMISSION TO COPY OR REVISE THIS DRAWING OR TO USE THIS DRAWING FOR PRODUCTION IS STRICTLY PROHIBITED AND CAN ONLY BE COPIED, REVISED OR USED FOR PRODUCTION WITH THE EXPRESSED WRITTEN PERMISSION OF SIGNCOMP.

DRAWN	3/30/2010	<h1>SignComp</h1> <p>Series 2 Slide Body - Assembly</p>			
CHECKED					
QA					
MFG					
APPROVED					
SIZE	C	DWG NO	K1110	REV	
SCALE		SHEET 1 OF 1			

Ship To:
Order #:

Parts List			
ITEM	PART	DESCRIPTION	NOTES
1	1100	Series 2 Square Post	
2	1200	Series 2/3 Reveal (Filler)	Tack weld or mechanically fasten to post

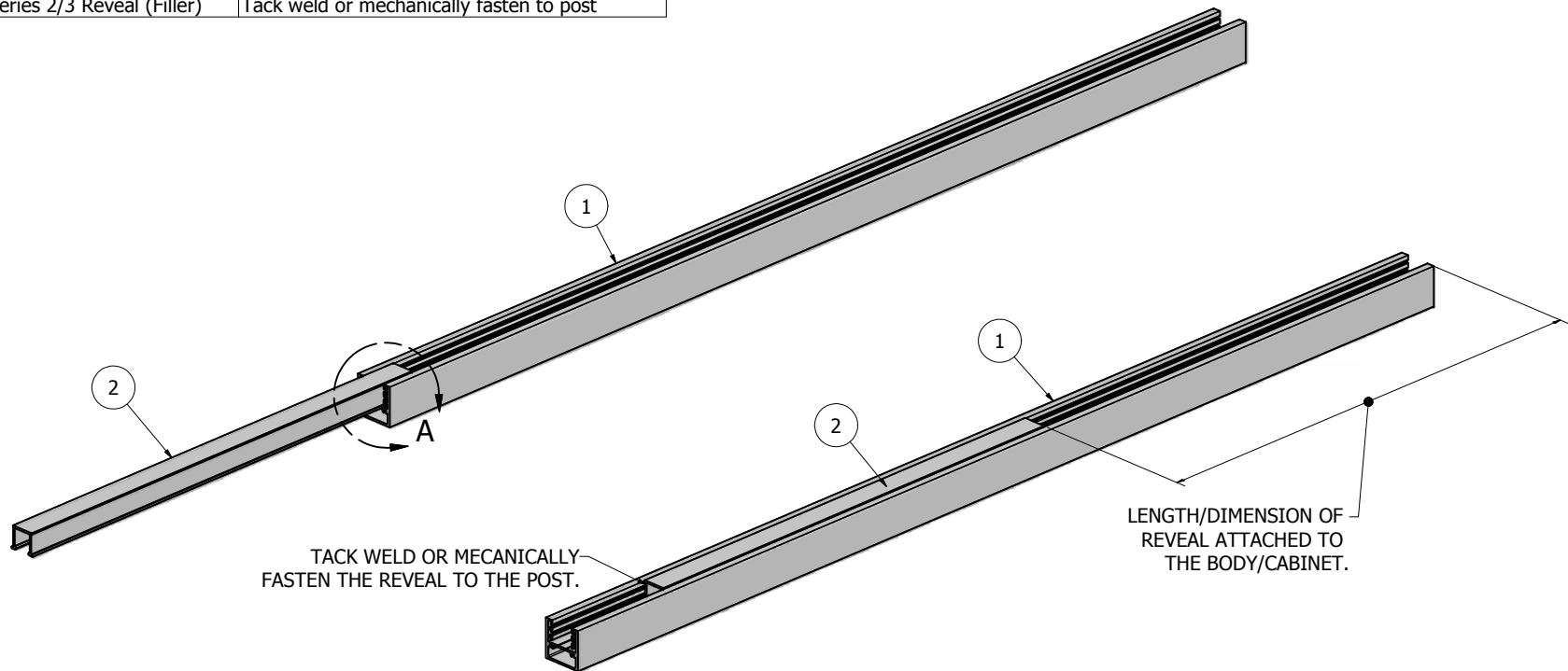

TACK WELD OR MECANICALLY FASTEN THE REVEAL TO THE POST.

LENGTH/DIMENSION OF REVEAL ATTACHED TO THE BODY/CABINET.

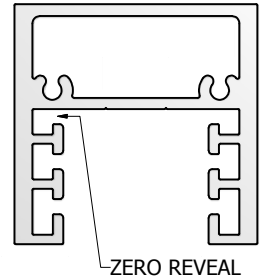

NOTE: PRE-CUT KITS ARE NOT PRE-DRILLED.
 (Holes shown in this drawing are for reference only.
 Drilling of pilot holes are to be done by fabricator.)

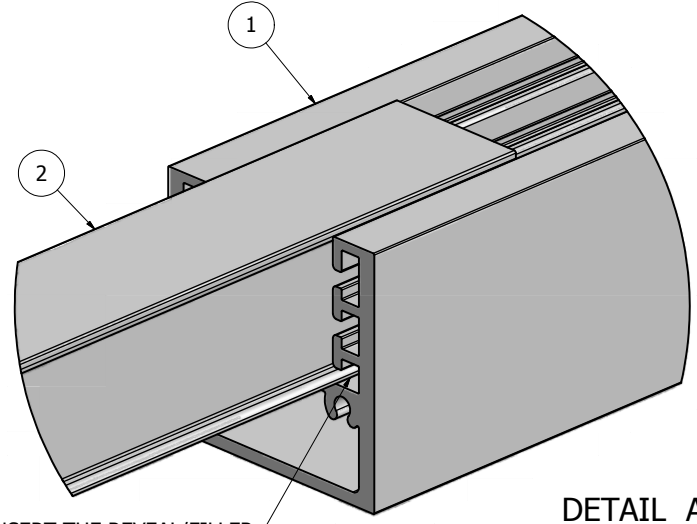

INSERT THE REVEAL/FILLER INTO THE ZERO REVEAL POSTION. SLIDED IT UP INTO THE POST.

DETAIL A

Ship To:
 Order #:

THIS DRAWING WAS CREATED AT NO CHARGE TO ASSIST YOU IN VISUALIZING OUR PROPOSAL. THE DRAWING HEREIN IS THE PROPERTY OF SIGNCOMP. PERMISSION TO COPY OR REVISE THIS DRAWING OR TO USE THIS DRAWING FOR PRODUCTION IS STRICTLY PROHIBITED AND CAN ONLY BE COPIED, REVISED OR USED FOR PRODUCTION WITH THE EXPRESSED WRITTEN PERMISSION OF SIGNCOMP.

DRAWN	3/31/2010	SignComp	
CHECKED			
QA		TITLE	
MFG		Series 2 Square Post - Series 2/3 Reveal Assembly	
APPROVED		SIZE	DWG NO
		C	K1100-00
		SCALE	SHEET 1 OF 1