

STD-13 for Rigid Faces - Electrical

2Part 12" Body  
Part #1929

2Part Extended Retainer  
Part #1940

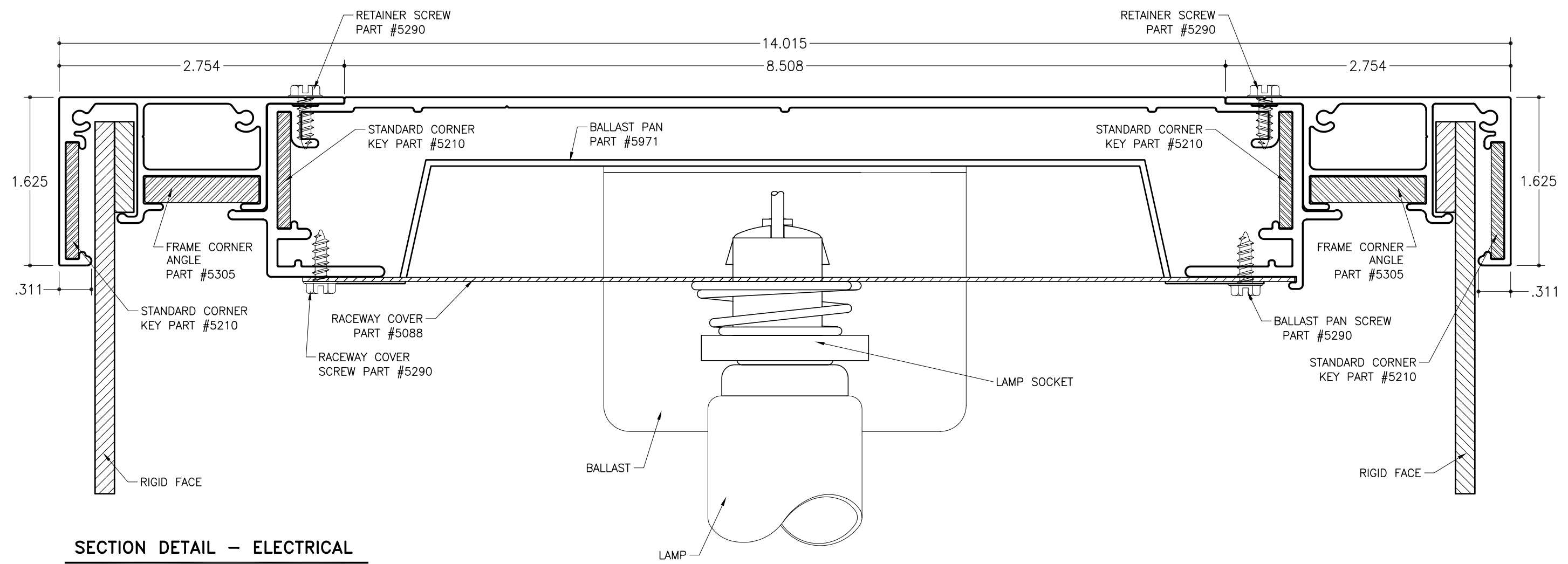

**SECTION DETAIL - ELECTRICAL**

SCALE : 1" = 1"

- NOTES:
1. Add 1½" to 1¾" to the overall width or height of cabinet depending on which direction the lamps will be placed. (vertical or horizontal)
  2. SignComp does not supply the ballast(s), lamps or lamp sockets.

STD-13 for Rigid Faces – Structural Corner

2Part 12" Body  
Part #1929

2Part Extended Retainer  
Part #1940

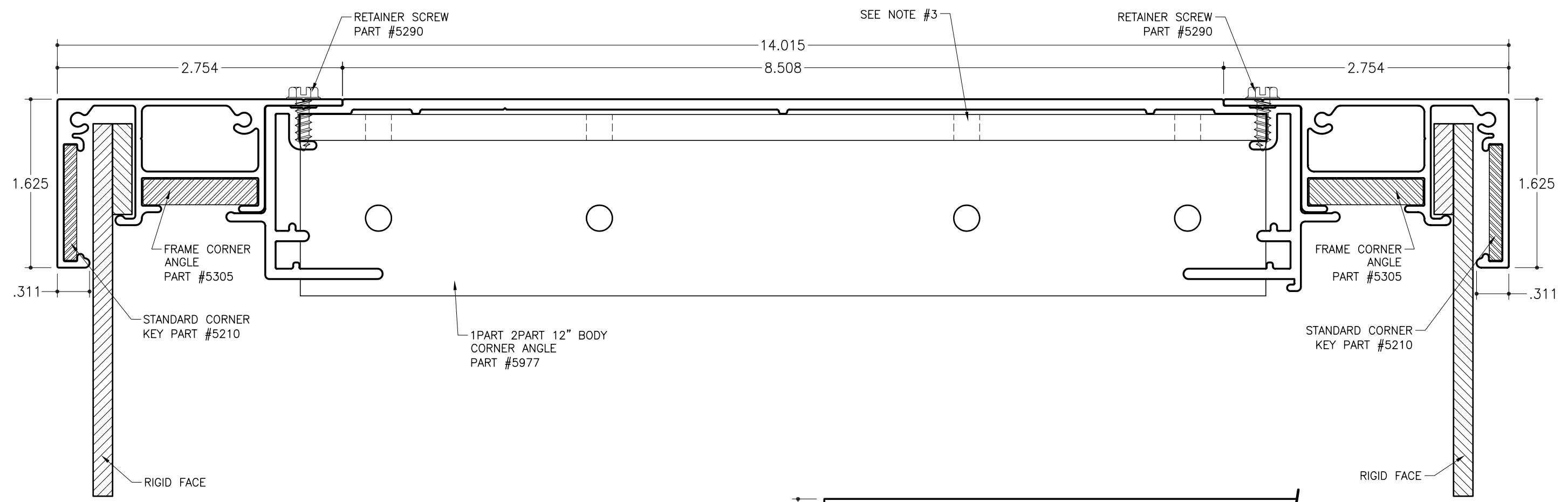

**SECTION DETAIL – ADHESIVE BONDED**

SCALE : 1" = 1"

- NOTES:
1. Add 1½" to 1¾" to the overall width or height of cabinet depending on which direction the lamps will be placed. (vertical or horizontal)
  2. Hanging bar to be attached to back side of face. Attach hanging bar using mechanical fasteners or adhesive. (SEE DETAIL "A")
  3. Holes located in corner angles are adhesive injection points.

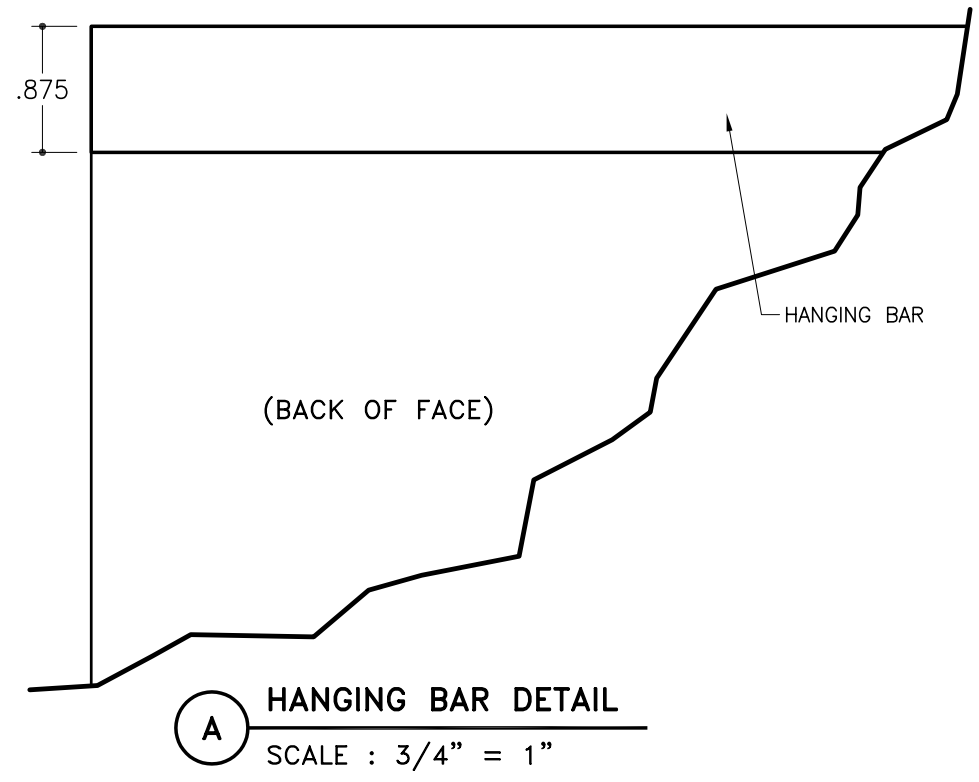

**A HANGING BAR DETAIL**  
SCALE : 3/4" = 1"

STD-13 for Rigid Faces – Structural Corner

2Part 12" Body  
Part #1929

2Part Extended Retainer  
Part #1940

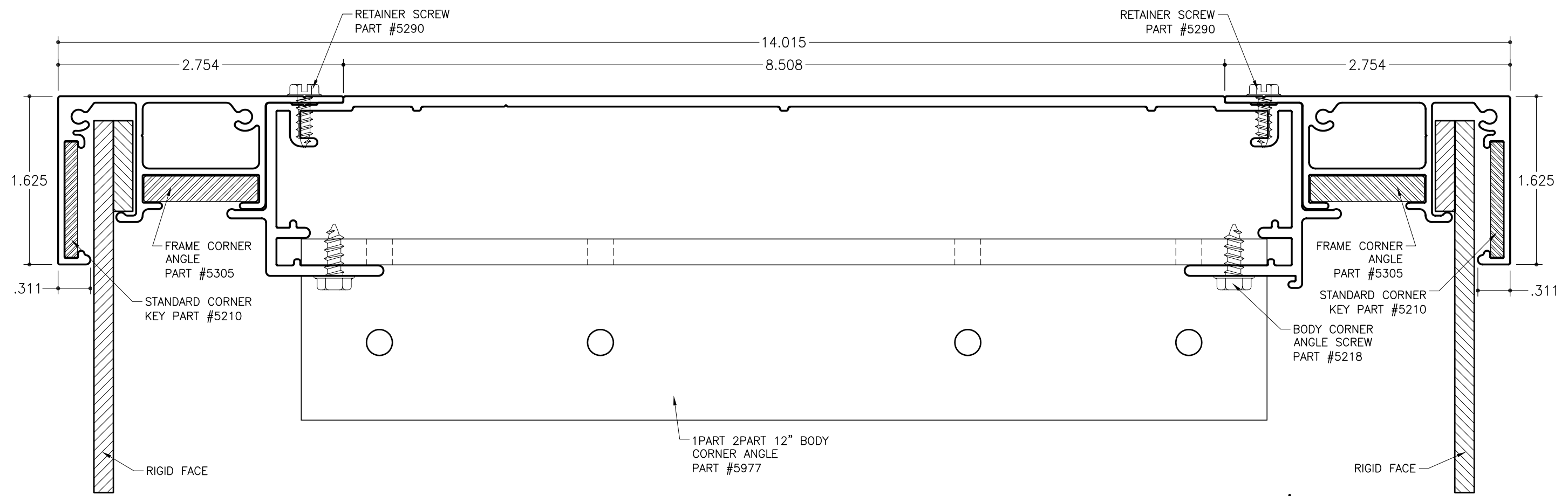

**SECTION DETAIL – MECHANICALLY FASTENED**

SCALE : 1" = 1"

- NOTES:
1. Add 1½" to 1¾" to the overall width or height of cabinet depending on which direction the lamps will be placed. (vertical or horizontal)
  2. Hanging bar to be attached to back side of face. Attach hanging bar using mechanical fasteners or adhesive. (SEE DETAIL "A")

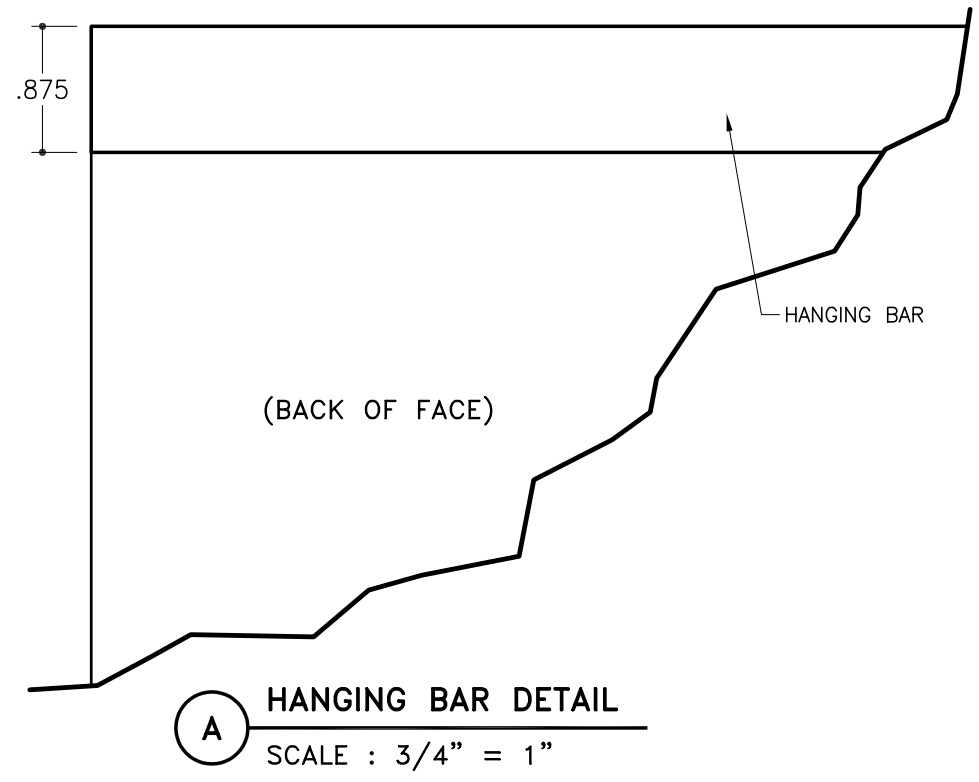

**A HANGING BAR DETAIL**  
SCALE : 3/4" = 1"

STD-13 for Rigid Faces – Structural Corner

2Part 12" Body  
Part #1929

2Part Extended Retainer  
Part #1940

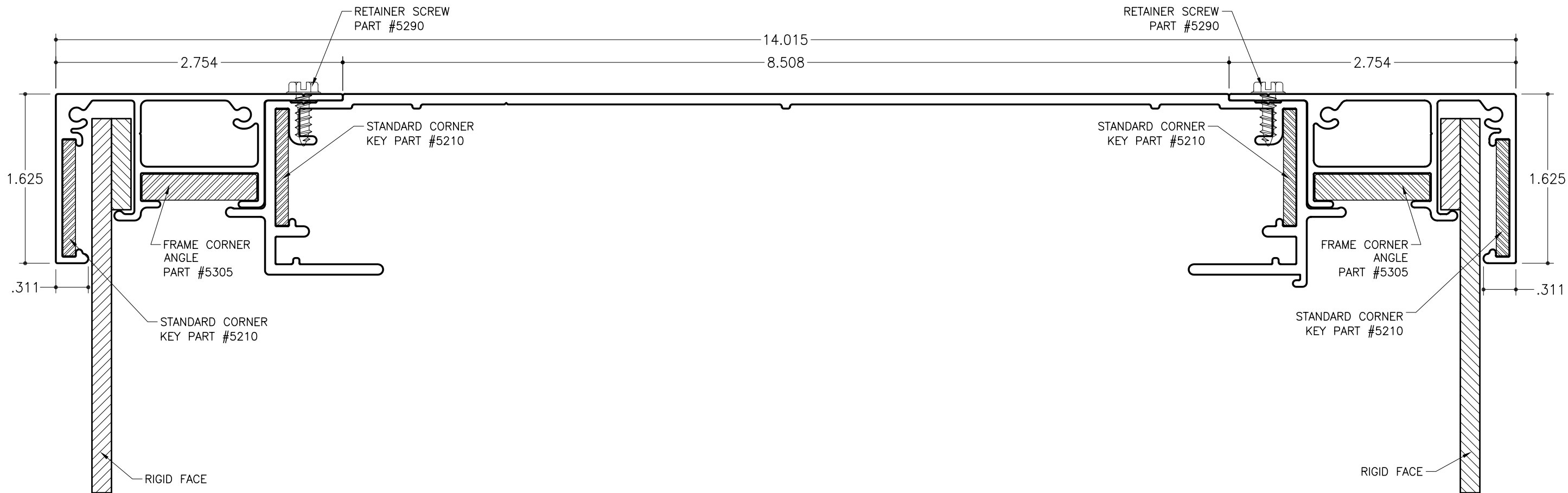

**CORNER DETAIL – CORNER KEYS / WELDED**

SCALE : 1" = 1"

- NOTES:
1. Add 1½" to 1¾" to the overall width or height of cabinet depending on which direction the lamps will be placed. (vertical or horizontal)
  2. Hanging bar to be attached to back side of face. Attach hanging bar using mechanical fasteners or adhesive. (SEE DETAIL "A")

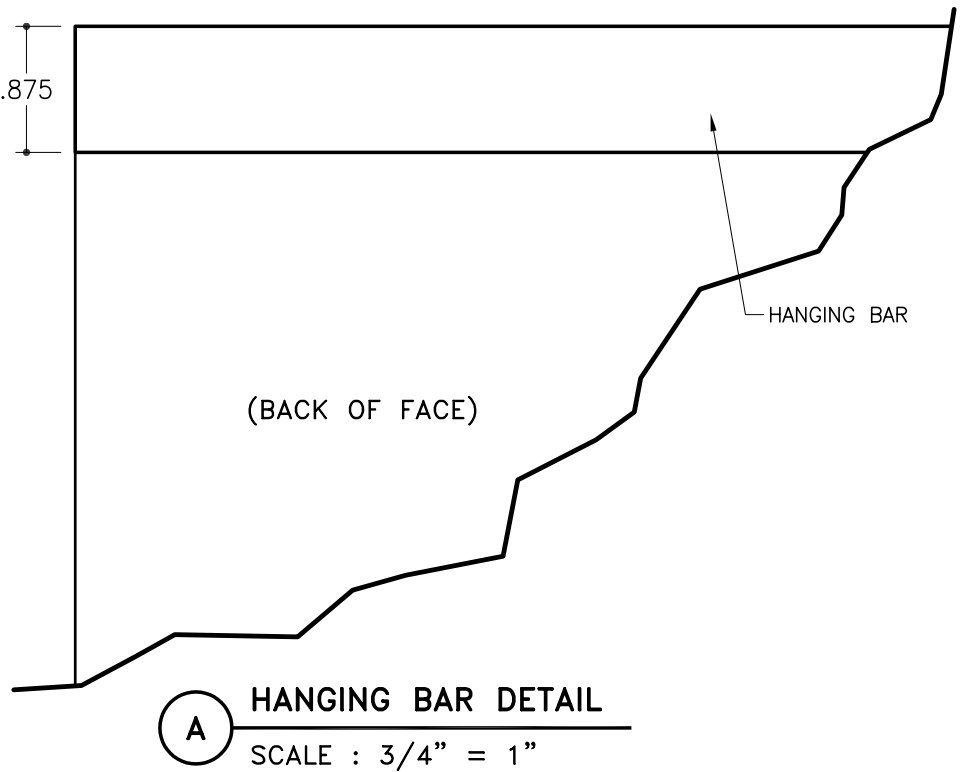

**A** HANGING BAR DETAIL  
SCALE : 3/4" = 1"

STD-13 for Rigid Faces – Structural Corner

2Part 12" Body  
Part #1929

2Part Extended Retainer  
Part #1940

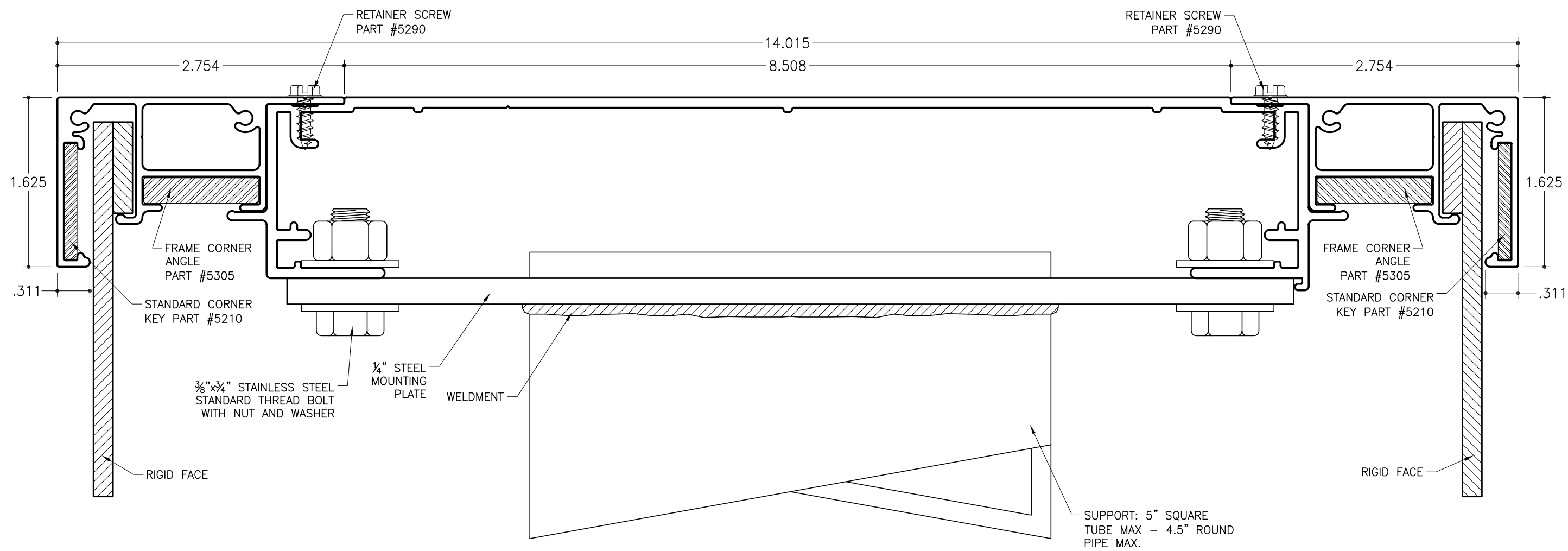

**SECTION DETAIL – MECHANICALLY FASTENED**

SCALE : 1" = 1"

- NOTES:
1. Add 1/2" to 3/4" to the overall width or height of cabinet depending on which direction the lamps will be placed. (vertical or horizontal)
  2. Max Supports – 5" Square Tube, 4.5" Round Pipe Supports.

STD-13 for Rigid Faces - Side

2Part 12" Body  
Part #1929

2Part Extended Retainer  
Part #1940

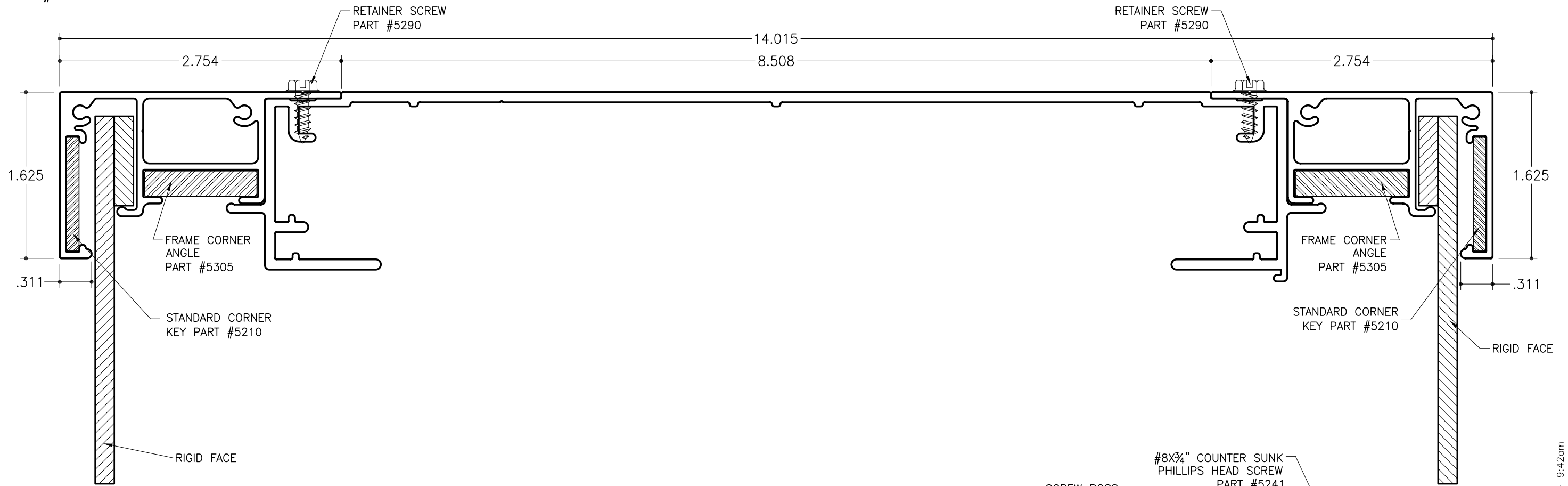

**SECTION DETAIL - SIDE**

SCALE : 1" = 1"

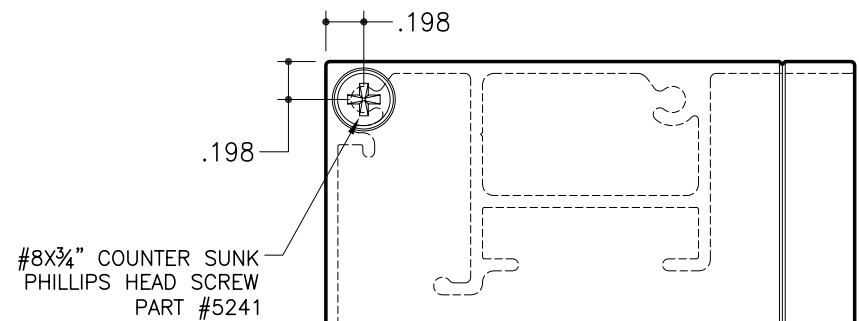

**A** SIDE VIEW  
SCALE : 1"=1"

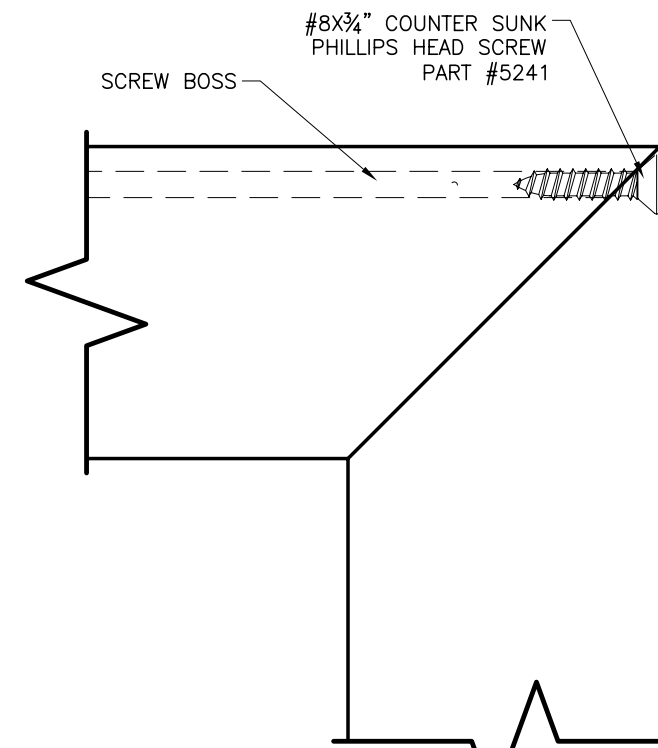

**B** FACE VIEW  
SCALE : 1"=1"

NOTES:

1. Add 1/2" to 3/4" to the overall width or height of cabinet depending on which direction the lamps will be placed. (vertical or horizontal)
2. 2Part Extended Retainer has two (2) screw boss for fastening to insure a tight fit. Only the outside screw boss is used when it is attached to the 2Part bodies.