

STD-17 for Rigid Faces - Electrical

2Part 9" Body
Part #1928

2" Extended Retainer
Part #1939

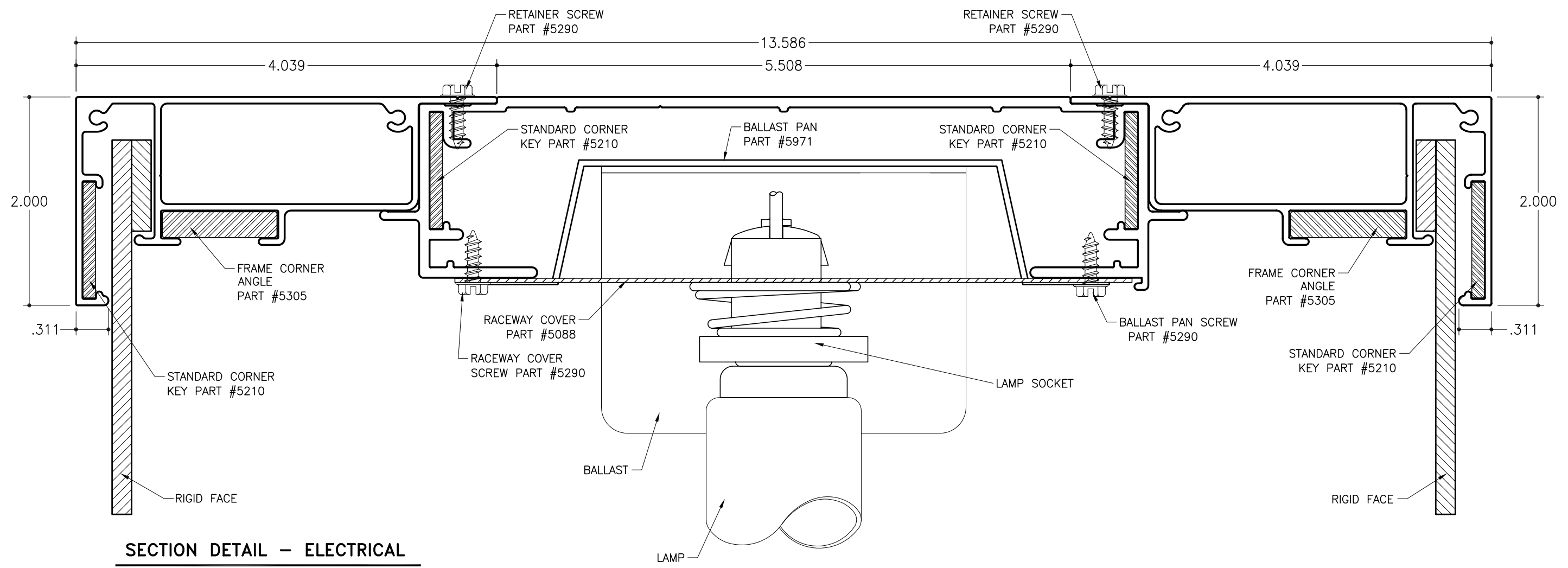

SECTION DETAIL - ELECTRICAL
SCALE : 1" = 1"

- NOTES:
1. Add 1½" to 1¾" to the overall width or height of cabinet depending on which direction the lamps will be placed. (vertical or horizontal)
 2. SignComp does not supply the ballast(s), lamps or lamp sockets.

STD-17 for Rigid Faces – Structural Corner

2Part 9" Body
Part #1928

2" Extended Retainer
Part #1939

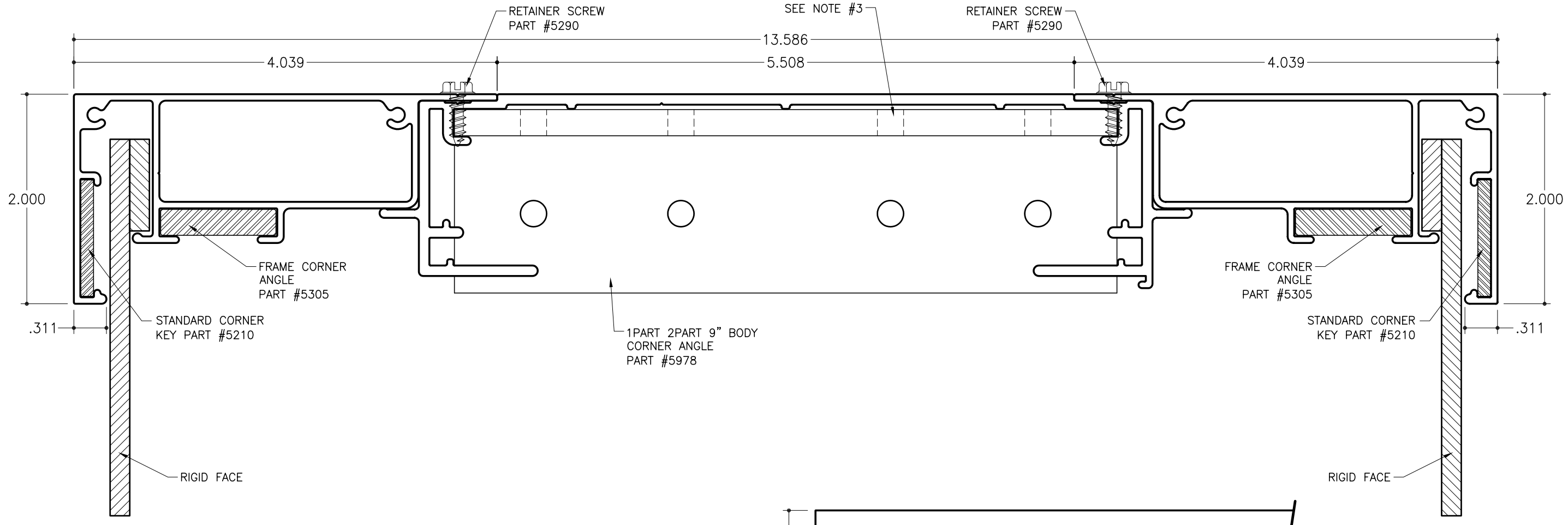

CORNER SECTION DETAIL (ADHESIVE BONDED)

SCALE : 1" = 1"

- NOTES:
1. Add 1½" to 1¾" to the overall width or height of cabinet depending on which direction the lamps will be placed. (vertical or horizontal)
 2. Hanging bar to be attached to back side of face. Attach hanging bar using mechanical fasteners or adhesive. (SEE DETAIL "A")
 3. Holes located in corner angles are adhesive injection points.

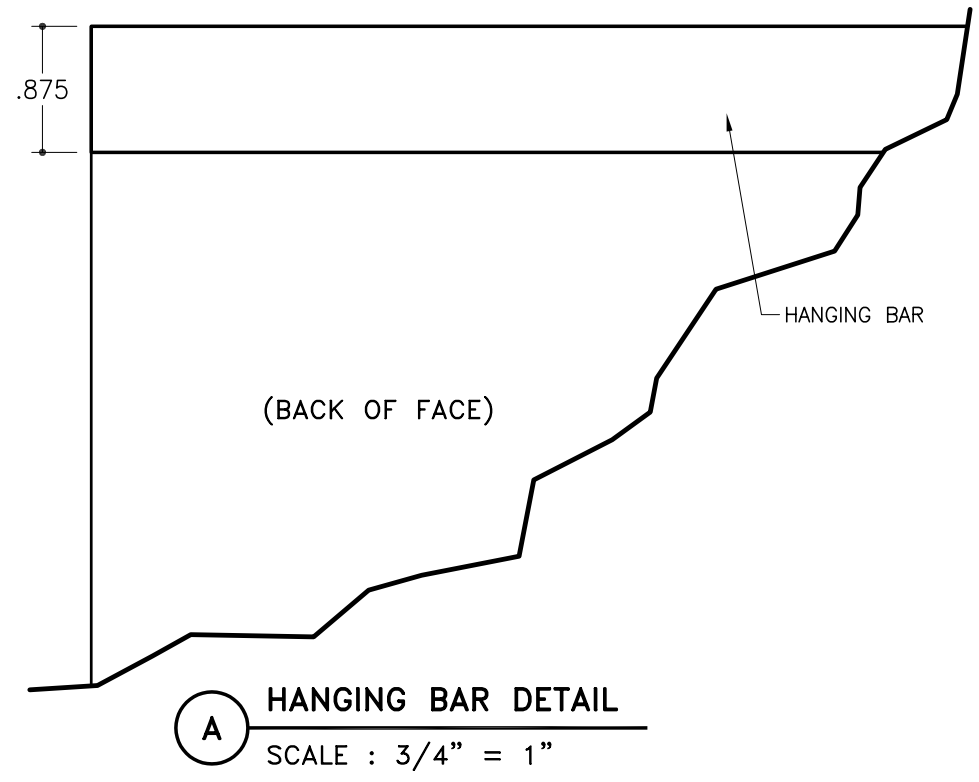

HANGING BAR DETAIL

SCALE : 3/4" = 1"

STD-17 for Rigid Faces – Structural Corner

2Part 9" Body
Part #1928

2" Extended Retainer
Part #1939

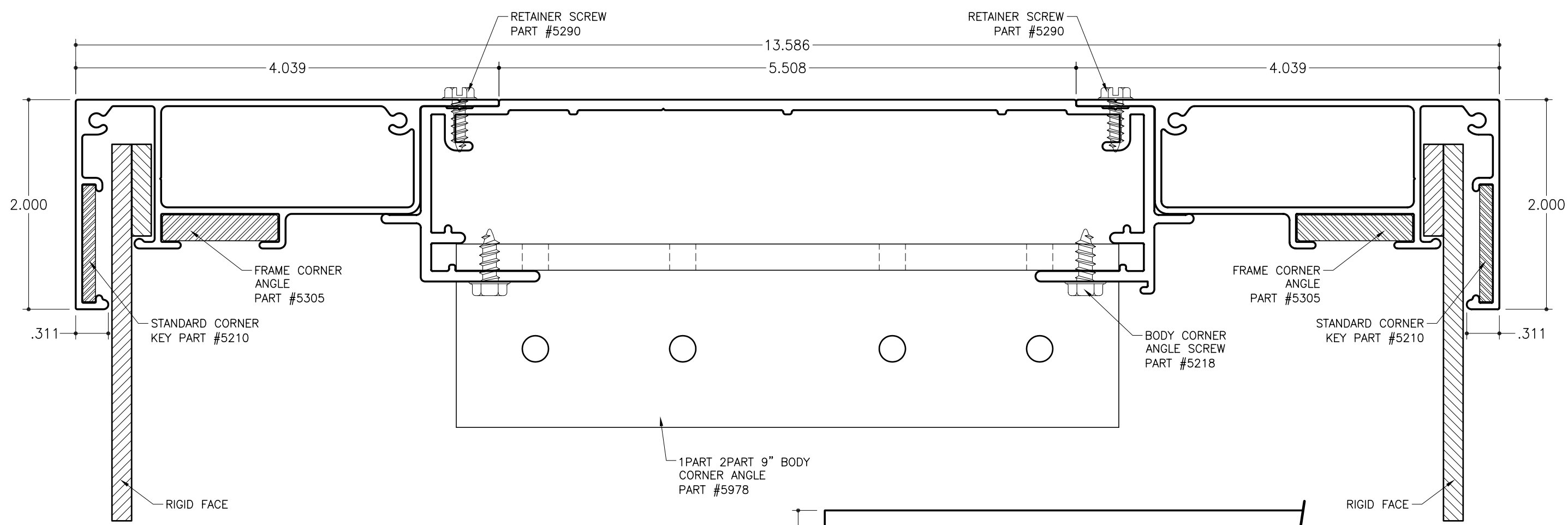

CORNER SECTION DETAIL (MECHANICALLY FASTENED)

SCALE : 1" = 1"

- NOTES:
1. Add 1½" to 1¾" to the overall width or height of cabinet depending on which direction the lamps will be placed. (vertical or horizontal)
 2. Hanging bar to be attached to back side of face. Attach hanging bar using mechanical fasteners or adhesive. (SEE DETAIL "A")

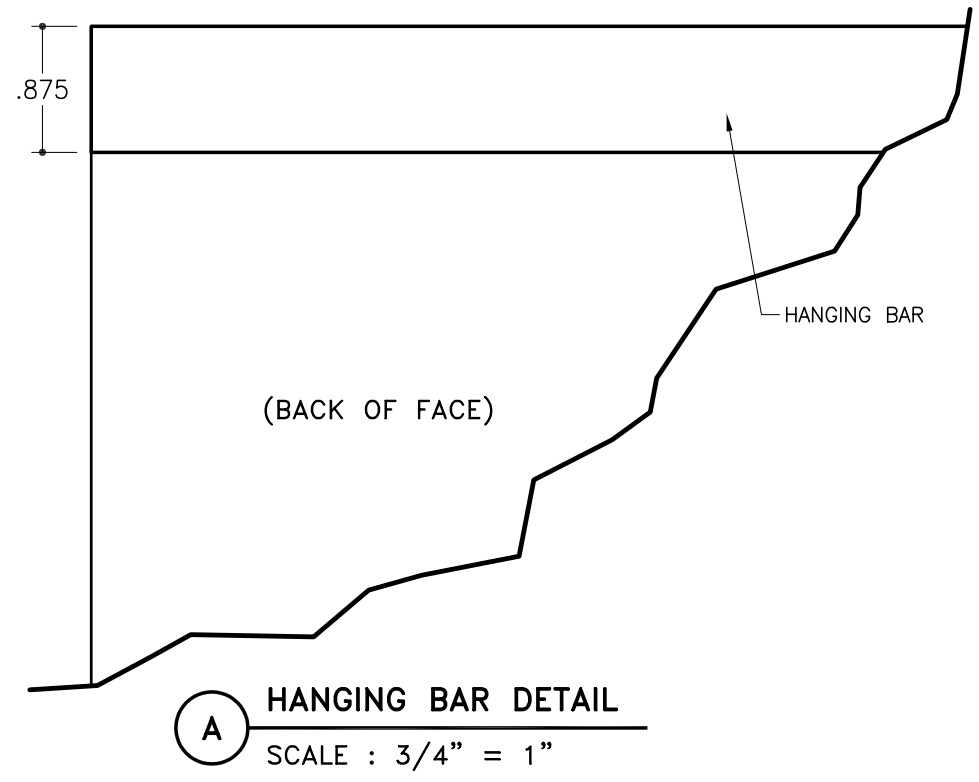

STD-17 for Rigid Faces – Structural Corner

2Part 9" Body
Part #1928

2" Extended Retainer
Part #1939

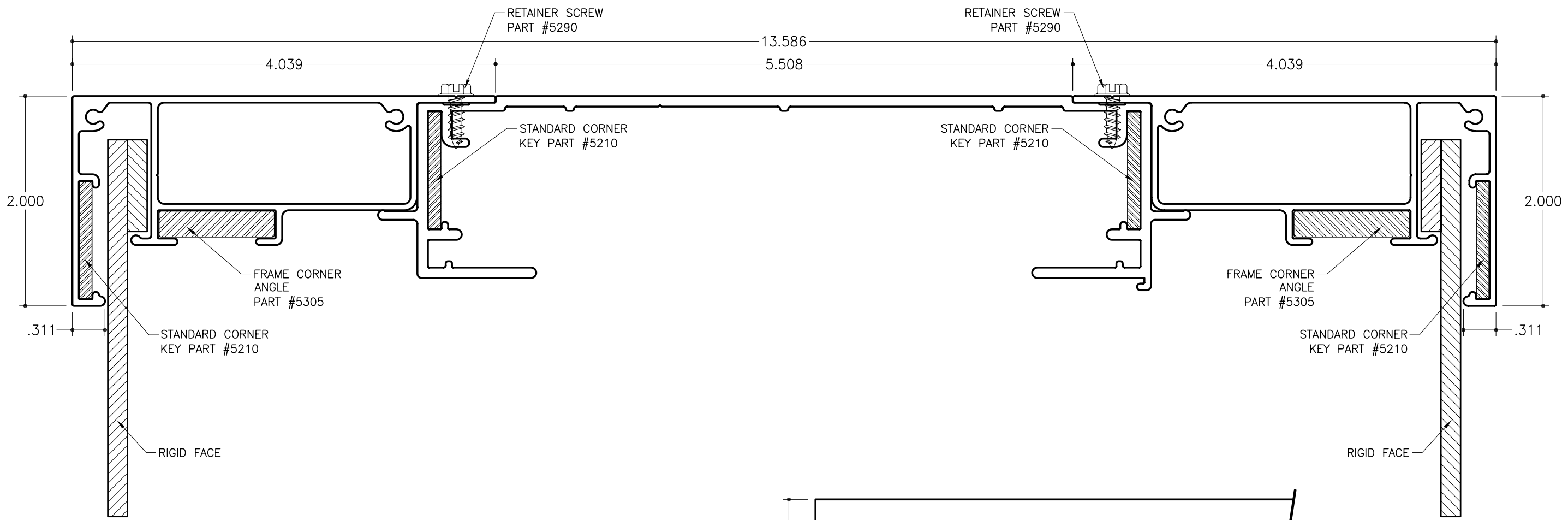

CORNER SECTION DETAIL (WELDED/CORNER KEYS)

SCALE : 1" = 1"

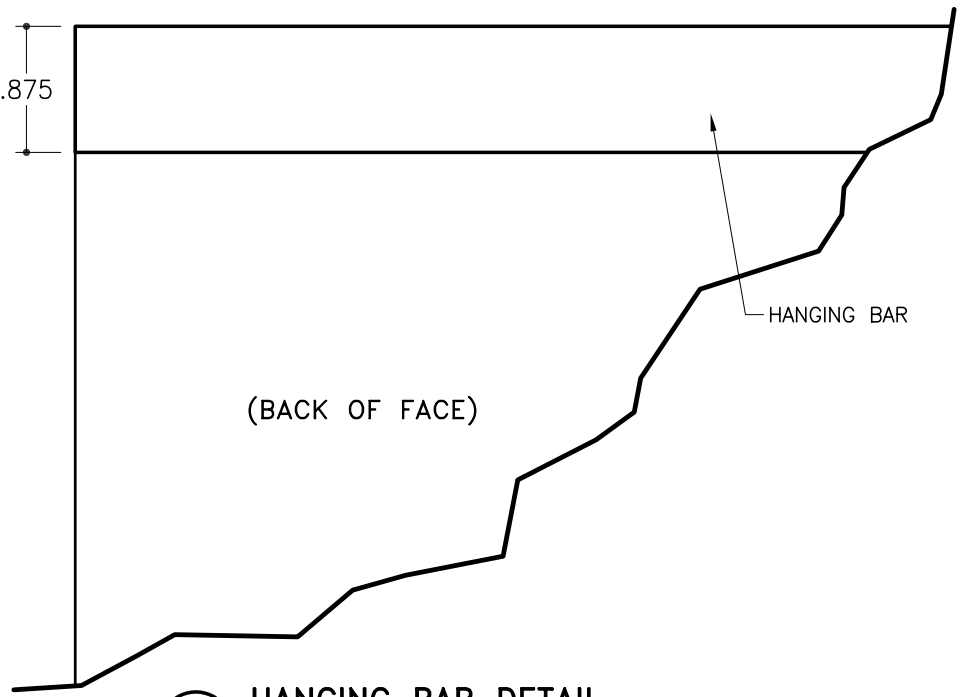

A HANGING BAR DETAIL
SCALE : 3/4" = 1"

NOTES:

1. Add 1½" to 1¾" to the overall width or height of cabinet depending on which direction the lamps will be placed. (vertical or horizontal)
2. Hanging bar to be attached to back side of face. Attach hanging bar using mechanical fasteners or adhesive. (SEE DETAIL "A")

STD-17 for Rigid Faces – Support

2Part 9" Body
Part #1928

2" Extended Retainer
Part #1939

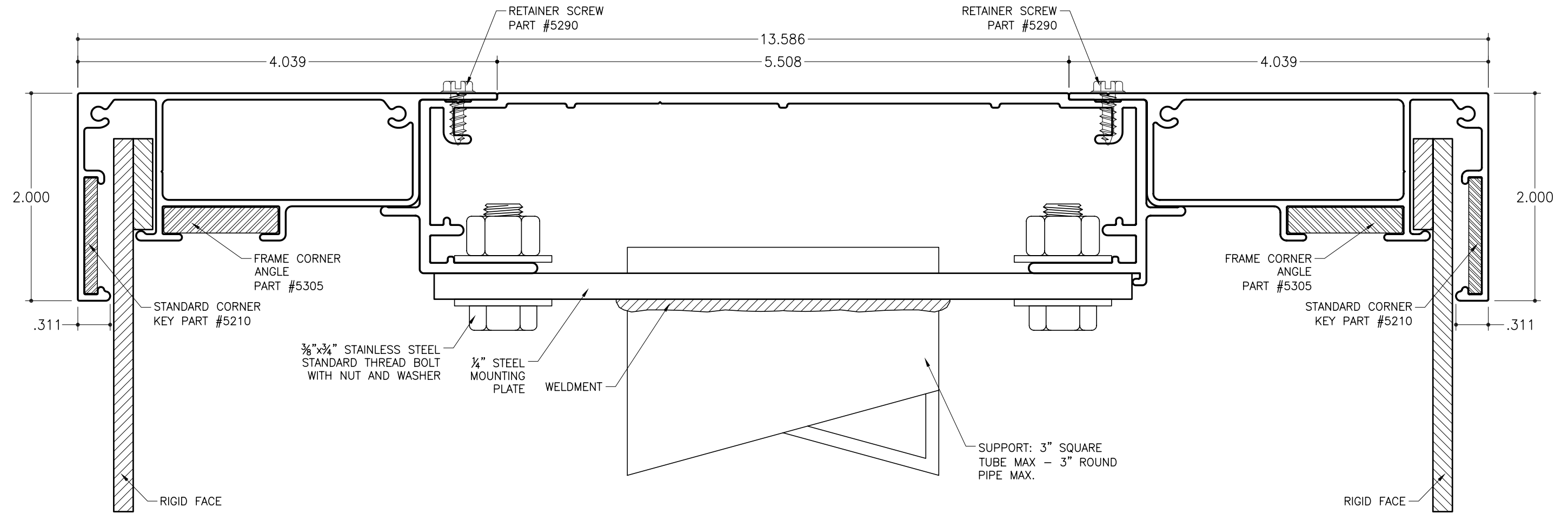

SECTION DETAIL – SUPPORT

SCALE : 1" = 1"

NOTES:

1. Add 1½" to 1¾" to the overall width or height of cabinet depending on which direction the lamps will be placed. (vertical or horizontal)
2. Max Support: 3" Square Tube or 3" Round Pipe Support.

STD-17 for Rigid Faces - Side

2Part 9" Body
Part #1928

2" Extended Retainer
Part #1939

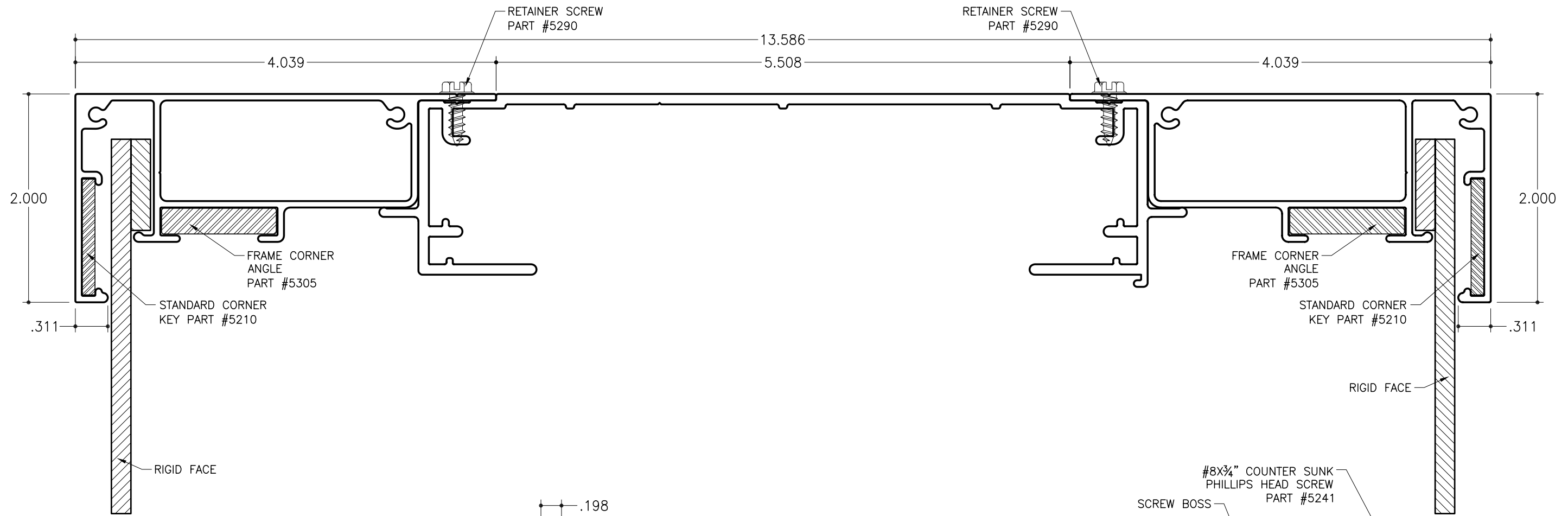

SECTION DETAIL - SIDE

SCALE : 1" = 1"

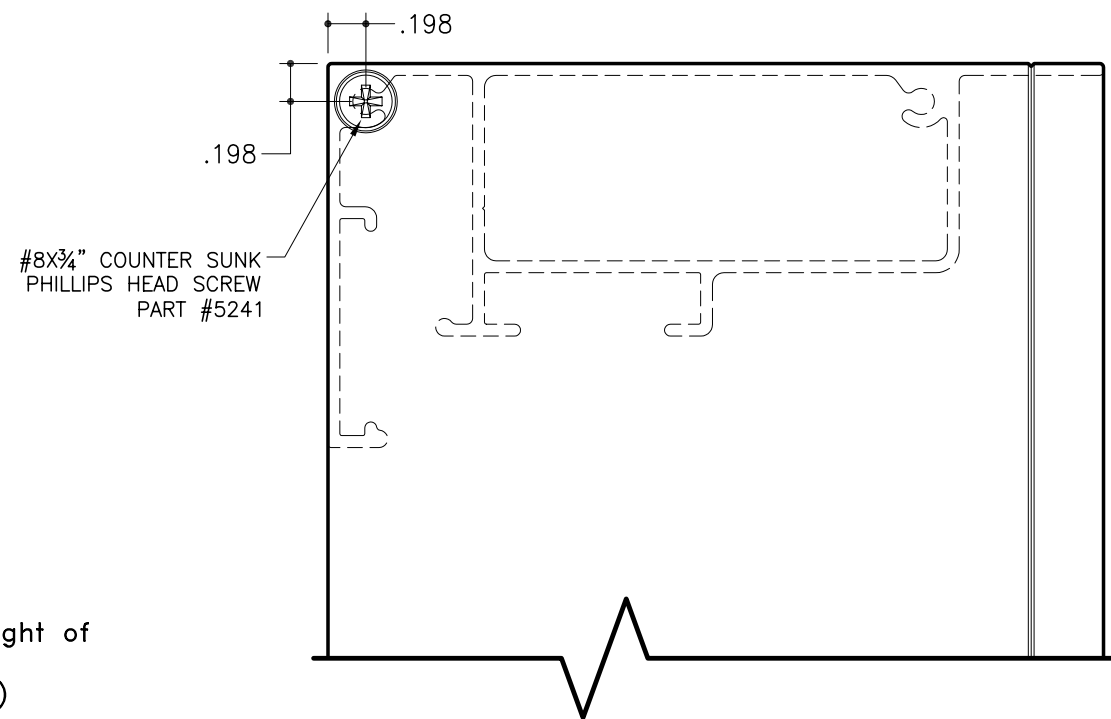

A SIDE VIEW
SCALE : 1"=1"

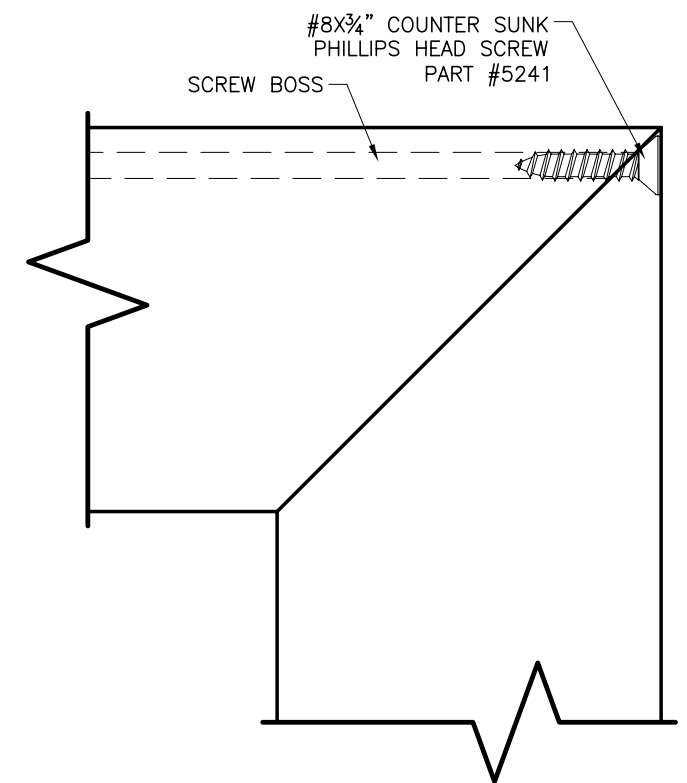

B FACE VIEW
SCALE : 1"=1"

- NOTES:
1. Add 1 1/2" to 1 3/4" to the overall width or height of cabinet depending on which direction the lamps will be placed. (vertical or horizontal)
 2. 2Part Extended Retainer has two (2) screw boss for fastening to insure a tight fit. Only the outside screw boss is used when it is attached to the 2Part bodies.