

SC-43 for Rigid Faces – Electrical

Medium Body
Part #2035

Large Inner Frame Retainer
Part #2097

2Part Large Outer Frame
Part #1941

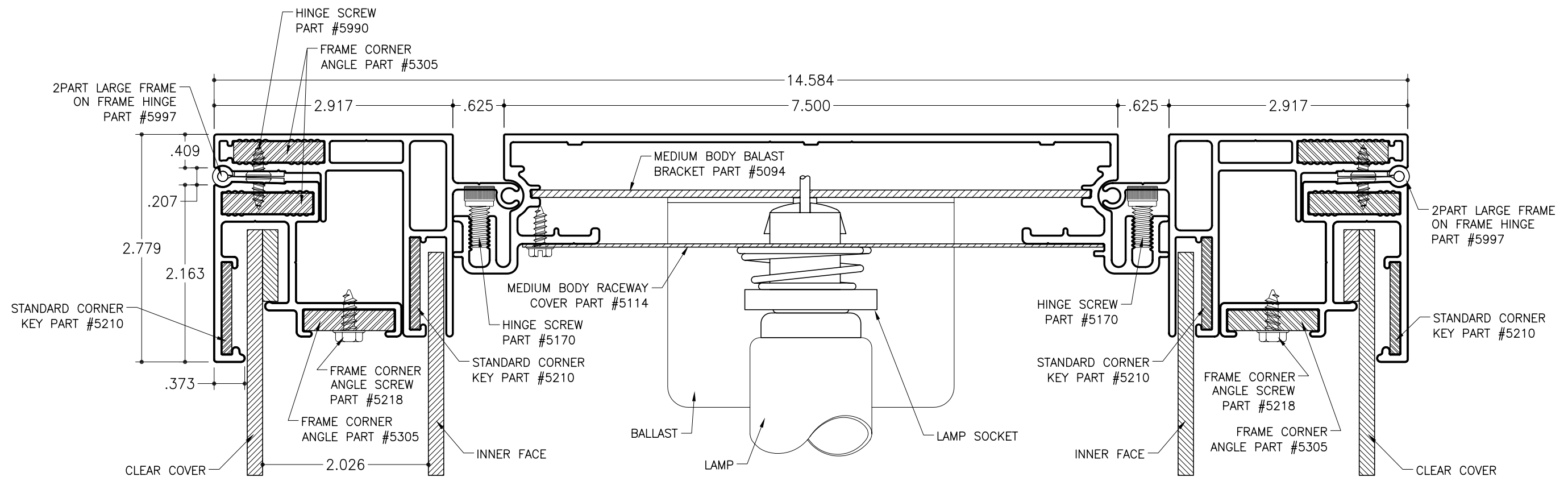

SECTION DEATIL (ELECTRICAL)
SCALE : 3/4"=1"

- NOTES:
1. Add 1" to the overall width or height of cabinet depending on which direction the lamps will be placed. (vertical or horizontal)
 2. SignComp does not supply the ballast(s), lamps or lamp sockets.
 3. 2Part Large Outer Frame to be cut $1\frac{3}{16}$ " less than the overall width and $1\frac{3}{8}$ " less than the overall height.
 4. Inner face hanging bar to be placed 3" in from edges of inner face, this will allow the hanging bar to clear the corner keys. The hanging bar is to be attached to the face side of the inner face.
 5. Hinge screws are to be 3" on center the first 16" in from each end the remainder 8"-10" apart.

SC-43 for Rigid Faces - Electrical

Medium Body
 Part #2015

Large Inner Frame Retainer
 Part #2097

2Part Large Outer Frame
 Part #1941

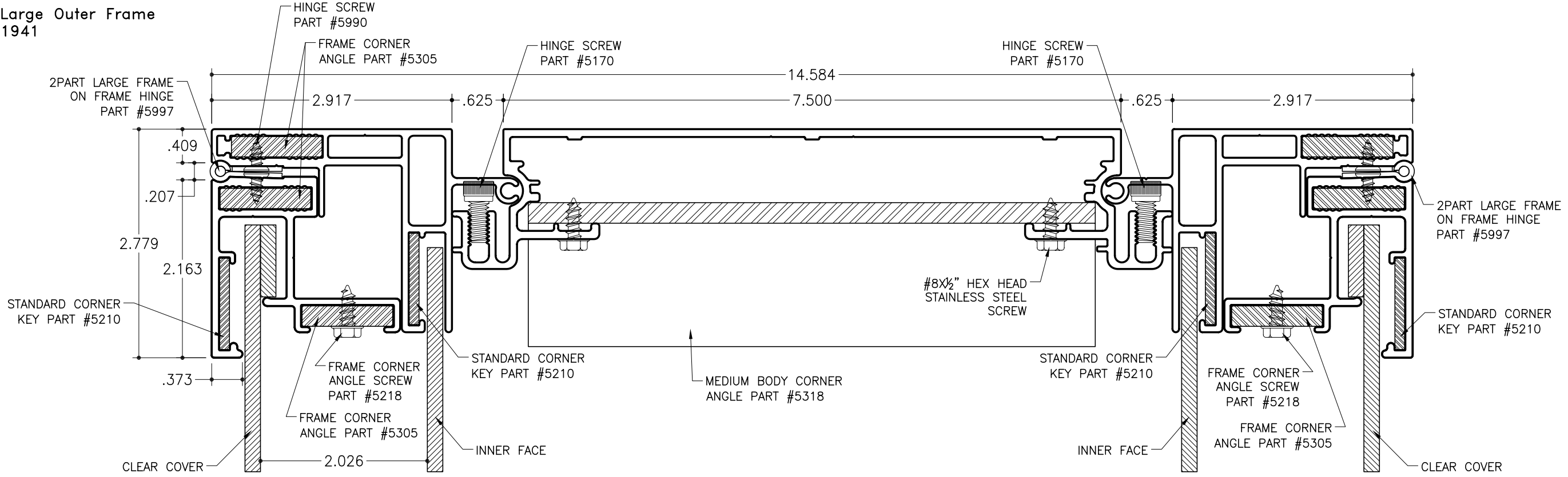

SECTION DETAIL STRUCTURAL (BODY CORNER ANGLE MECHANICALLY FASTENED)
 SCALE : 3/4" = 1"

- NOTES:
1. Add 1" to the overall width or height of cabinet depending on which direction the lamps will be placed. (vertical or horizontal)
 2. Corner angles can be secured by mechanically fastening or by using adhesive. NOTE: If corner angles are attached with adhesive it is recommended that one or both of the vertical frames are made to be removable for servicing. The corner angles that are to be attached with adhesive need to be located in the vertical frame and the opposite adjacent corner are mechanically fastened.
 3. 2Part Large Outer Frame to be cut 1 3/8" less than the overall width and 1 3/8" less than the overall height.
 4. Inner face hanging bar to be placed 3" in from edges of inner face, this will allow the hanging bar to clear the corner keys. The hanging bar is to be attached to the face side of the inner face.

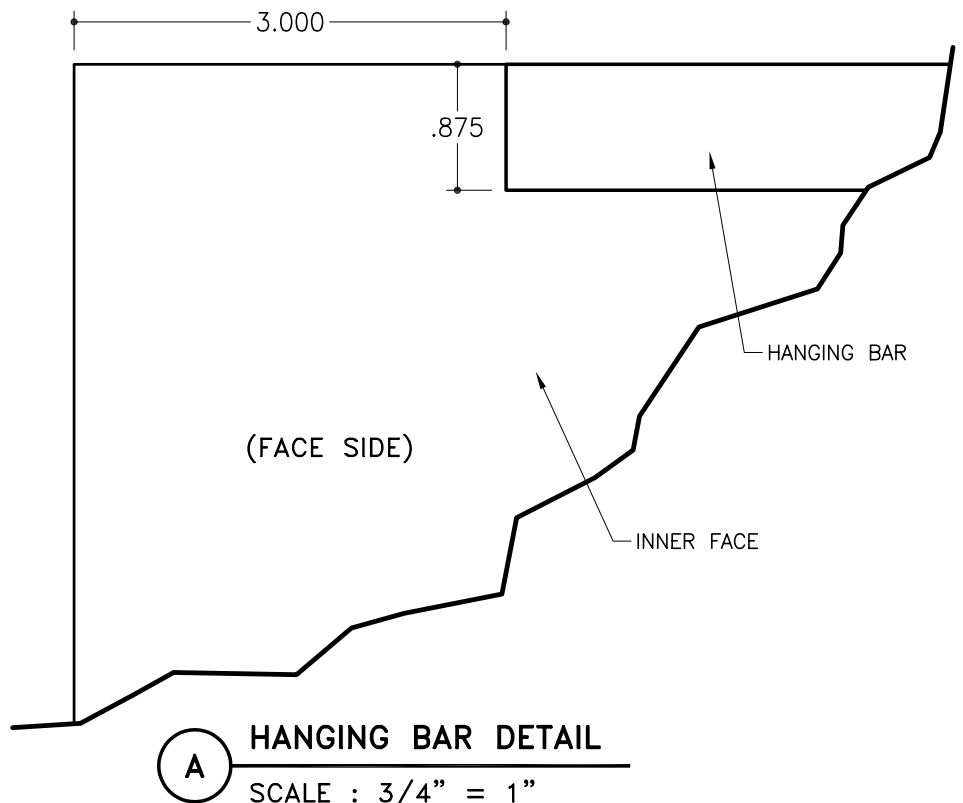

SC-43 for Rigid Faces - Electrical

Medium Body
 Part #2015

Large Inner Frame Retainer
 Part #2097

2Part Large Outer Frame
 Part #1941

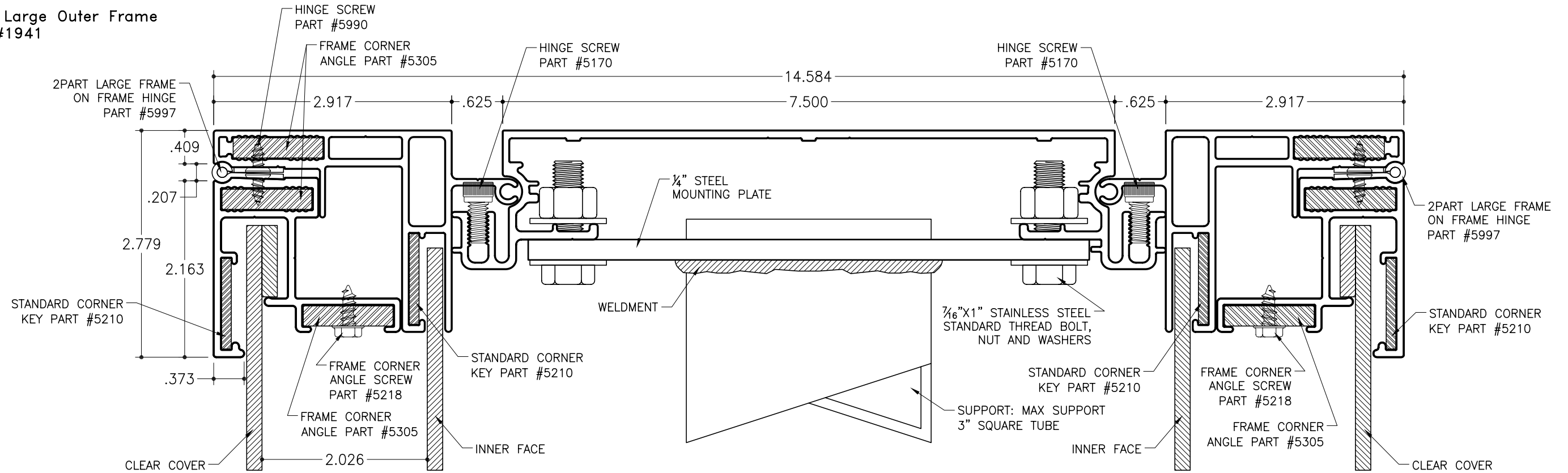

SECTION DETAIL STRUCTURAL (SUPPORT)

SCALE : 3/4" = 1"

NOTES:

1. Add 1" to the overall width or height of cabinet depending on which direction the lamps will be placed. (vertical or horizontal)
2. Corner angles can be secured by mechanically fastening or by using adhesive. NOTE: If corner angles are attached with adhesive it is recommended that one or both of the vertical frames are made to be removable for servicing. The corner angles that are to be attached with adhesive need to be located in the vertical frame and the opposite adjacent corner are mechanically fastened.
3. 2Part Large Outer Frame to be cut $1\frac{3}{16}$ " less than the overall width and $1\frac{3}{8}$ " less than the overall height.
4. Inner face hanging bar to be placed 3" in from edges of inner face, this will allow the hanging bar to clear the corner keys. The hanging bar is to be attached to the face side of the inner face.
5. Max Support: 3" Square Tube.

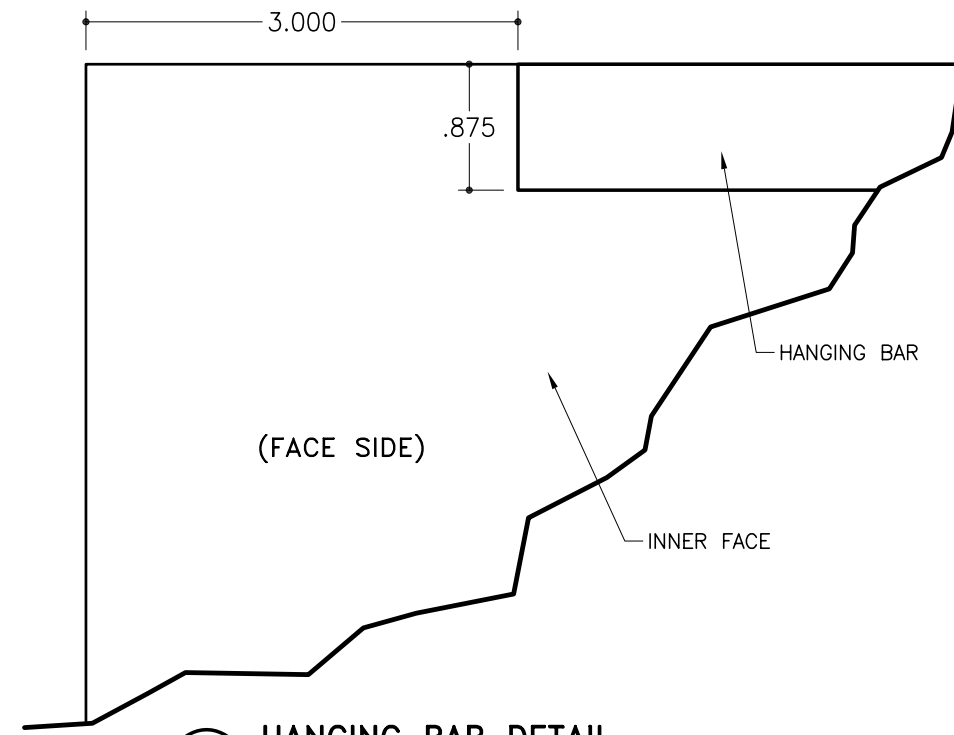

A HANGING BAR DETAIL
 SCALE : 3/4" = 1"

SC-43 for Rigid Faces - Lock

Medium Body
Part #2015

Large Inner Frame Retainer
Part #2097

2Part Large Outer Frame
Part #1941

2PART LARGE LOCK
PART #5993

CLOSURE SCREW
PART #5180

CLOSURE SCREW
PART #5180

2PART LARGE LOCK
PART #5993
CLEAR COVER

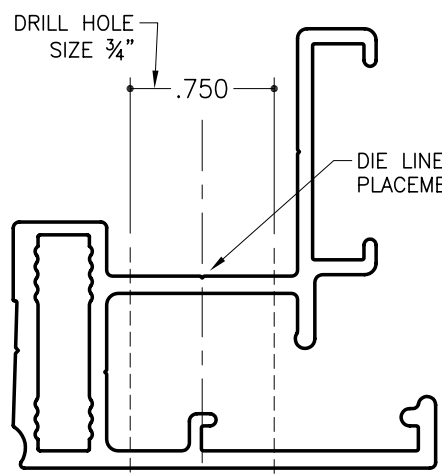

LOCK HOLE DETAIL

SCALE : 1" = 1"

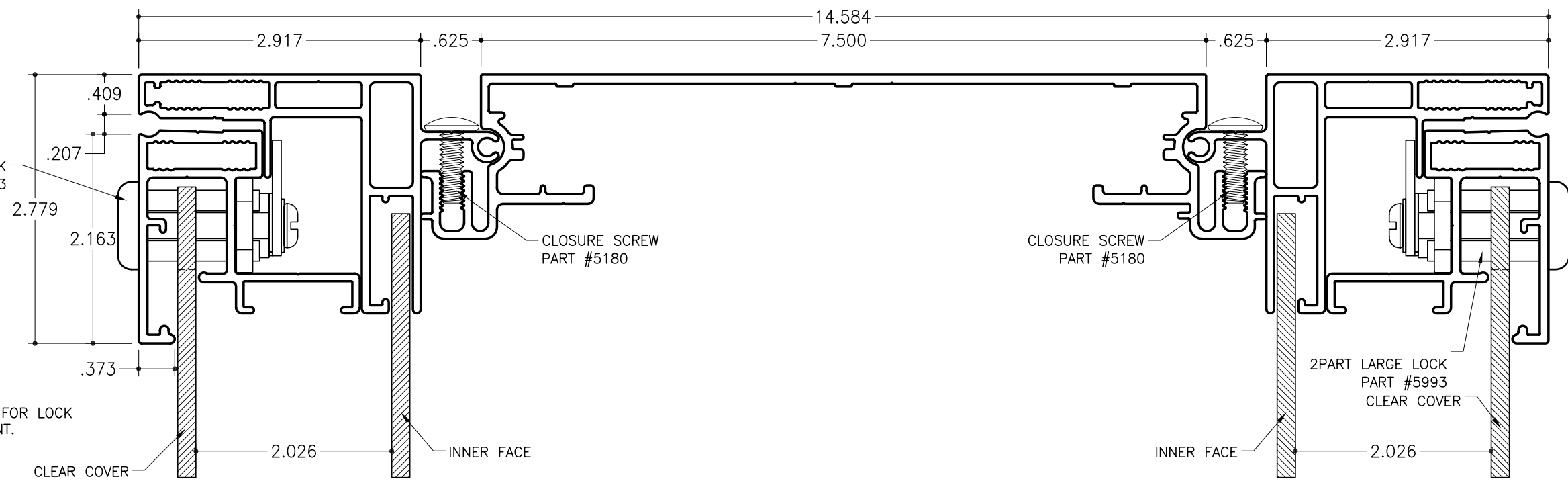

A SIDE SECTION DETAIL (LOCK)
SCALE : 3/4" = 1"

- NOTES:
1. Notch face to fit around lock leaving 1/8" of space around lock for proper expansion and contraction of face.
 2. DO NOT OVER TIGHTEN LOCK NUT. Over tightening lock nut will cause the space allowed for the face to sit too close down and the face not to slide into the channel.
 3. Apply "lock tight" to lock nut. Apply nut to lock and snug down.
 4. Locks can be placed on the side or bottom frame(s), As a guide line for placement of the locks times the height in feet or the width in feet by 3. This will give you the distance in inches where the locks can be placed on the 2Part Large Outer Frame.

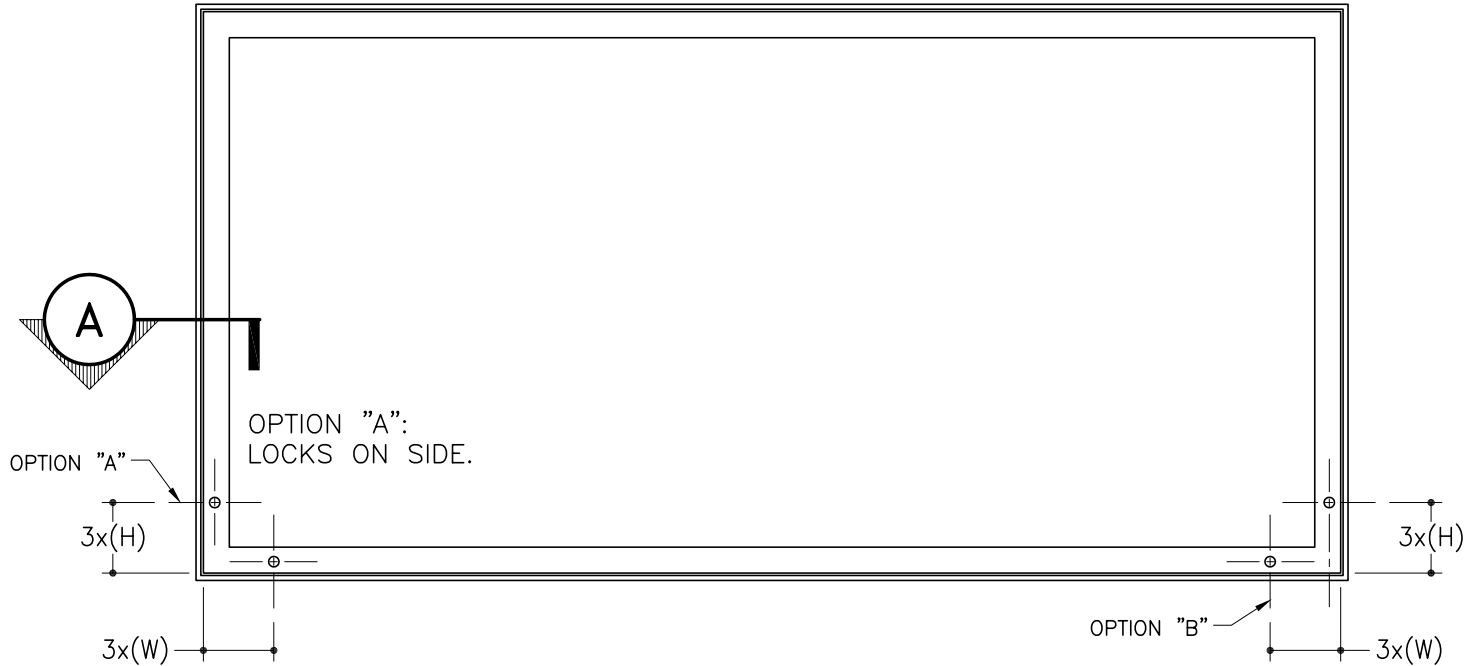

LOCK PLACEMENT

SCALE : 3/4" = 1'

SC-43 for Rigid Faces - Gas Support

Medium Body
Part #2015

Large Inner Frame Retainer
Part #2097

2Part Large Outer Frame
Part #1941

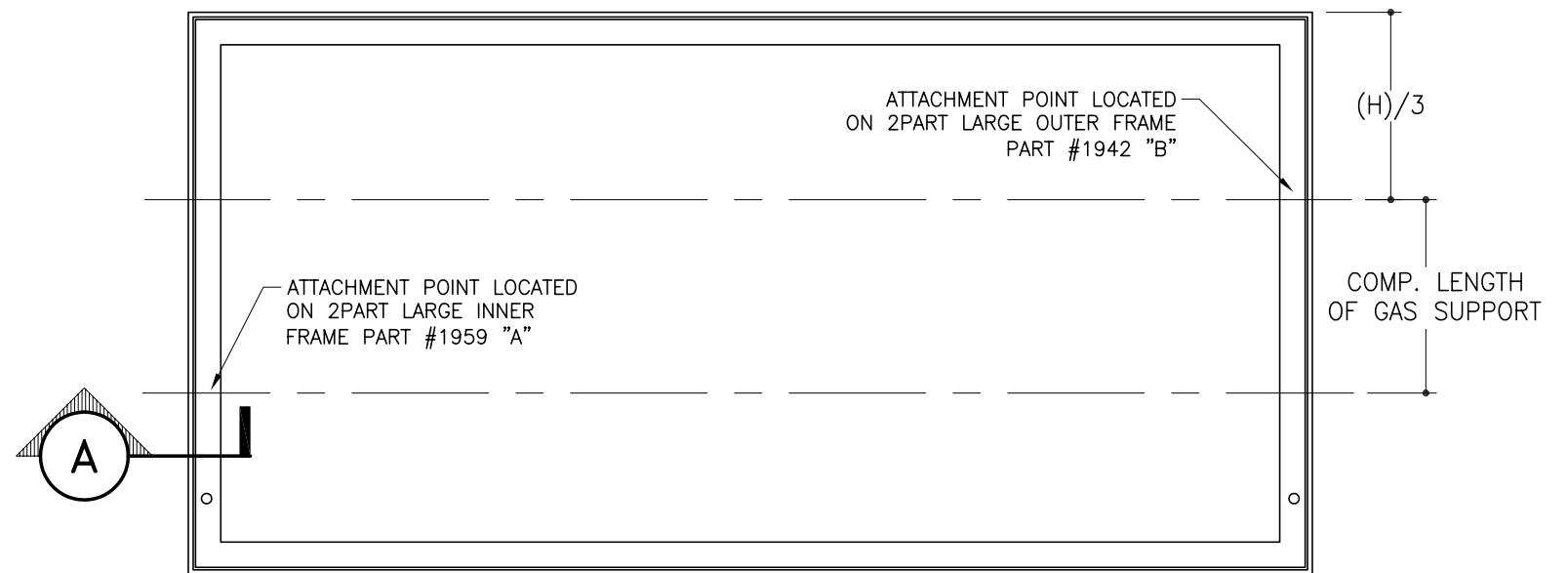
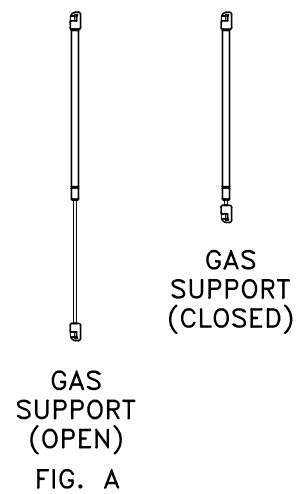
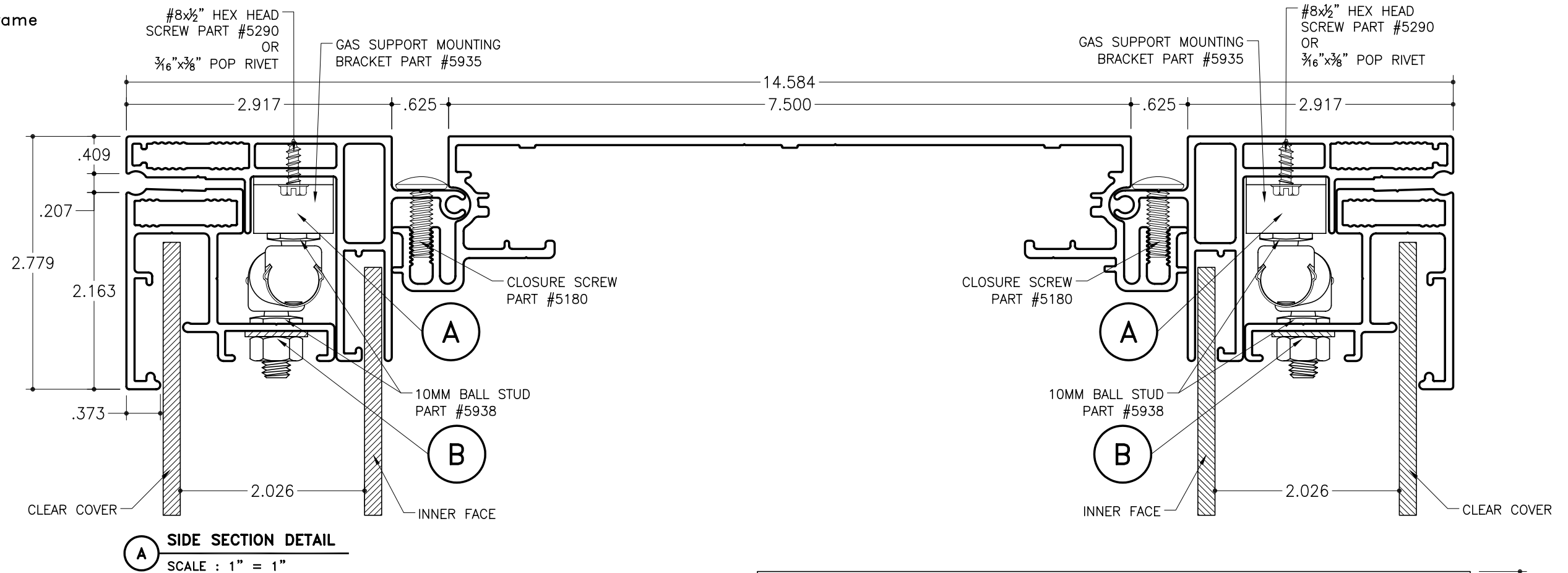

GAS SUPPORT PLACEMENT

SCALE : 3/4" = 1"

COMPRESSED LENGTH OF SUPPORTS:
 PART #5930 = 8.75"
 PART #5932 = 10.50"
 PART #5934 = 16.25"

NOTES:

1. Upper attachment point is located on Large Inner Frame Retainer. To find the location of the attachment point divide the overall height by 3.
2. Lower attachment point is located on 2Part Large Outer Frame. To find the location use the compressed length of the gas support.
3. Install on ball studs as shown right (Gas Support Open). Fig. A

SC-43 for Rigid Faces - Gas Supports

Medium Body
Part #2015

Large Inner Frame Retainer
Part #2097

2Part Large Outer Frame
Part #1941

SEE ATTACHMENT POINT "B"
ON SHEET 6 OF 7

SEE ATTACHMENT POINT "A"
ON SHEET 6 OF 7

(H)/3

COMP. LENGTH
OF GAS SUPPORT

A SECTION VIEW (INSIDE SIDE)
SCALE : 3/4" = 1"

B

A

B SECTION VIEW (FACE)
SCALE : 3/4" = 1"

