

SC-47 for Rigid Faces - Electrical

Single Face Body
Part #2025

Inner Frame Retainer
Part #2099

2Part Outer Frame
Part #1942

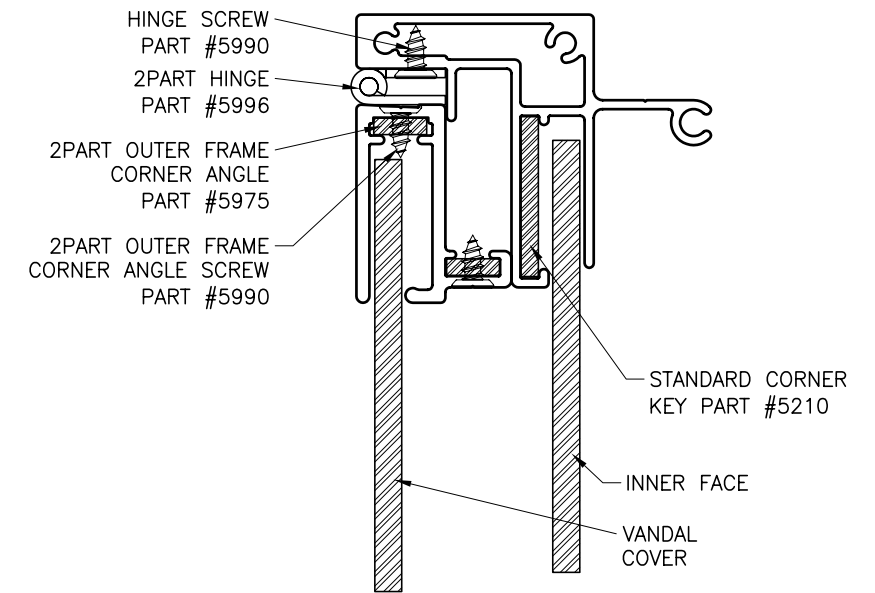
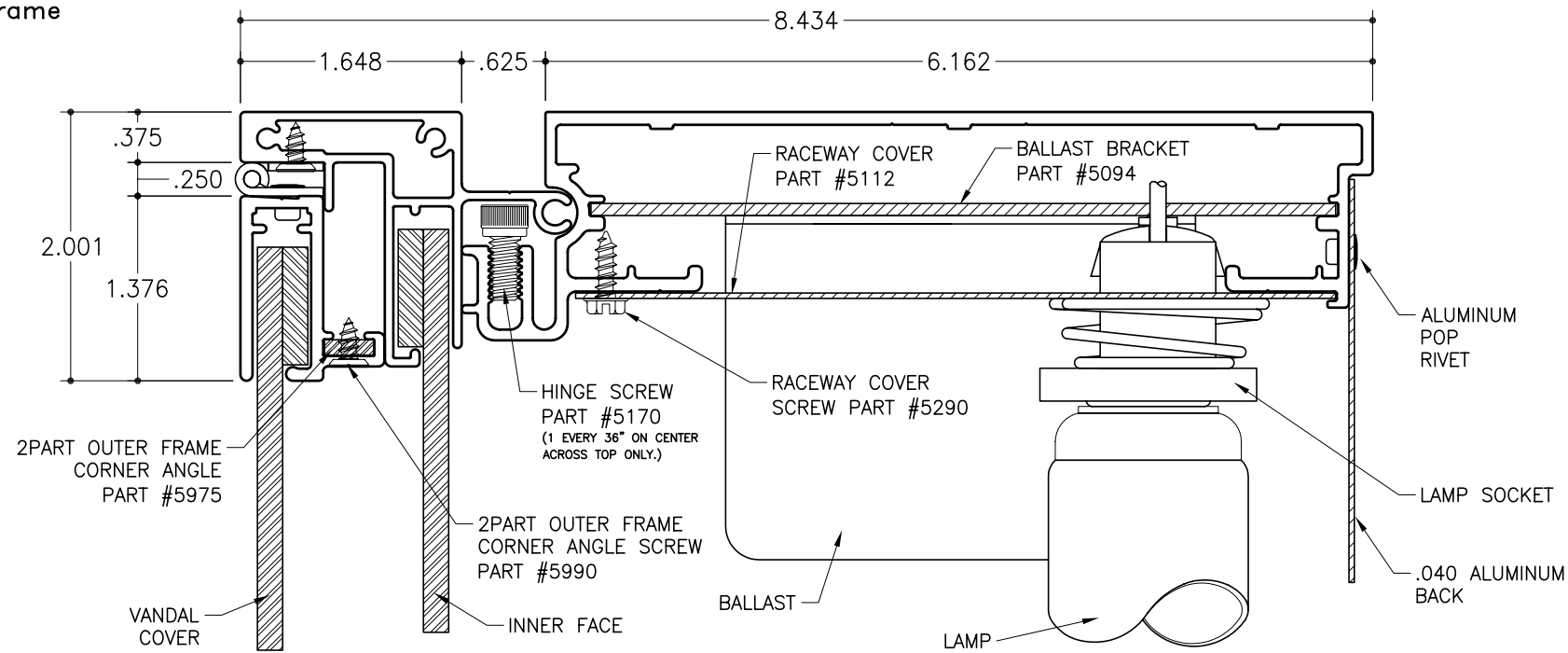

SECTION DETAIL

SCALE : 3/4"=1"

NOTES:

1. Add 1" to size of cabinet (vertical or horizontal) when the size of the cabinet is the same as the nominal lamp length.
2. SignComp does not supply the ballast's, lamps, or lamp sockets.
3. The 2Part Outer Frame to be cut 7/8" less than the overall width and 1-1/8" less than the overall height when it is hinged at the top. If hinging from the side is required then the 2Part Outer Frame is to be cut 1-1/8" less than the overall width and 7/8" less than the overall height.
4. Inner Face hanging bar is to be places 3" in from edges of cut to size face, this will allow the hanging bar to clear the corner keys. The hanging bar is to be attached to the face side of the face.
5. Hinge screws are to be 2"-3" on center the first 16" in from each end the remainder is to be placed 4"-6" apart.

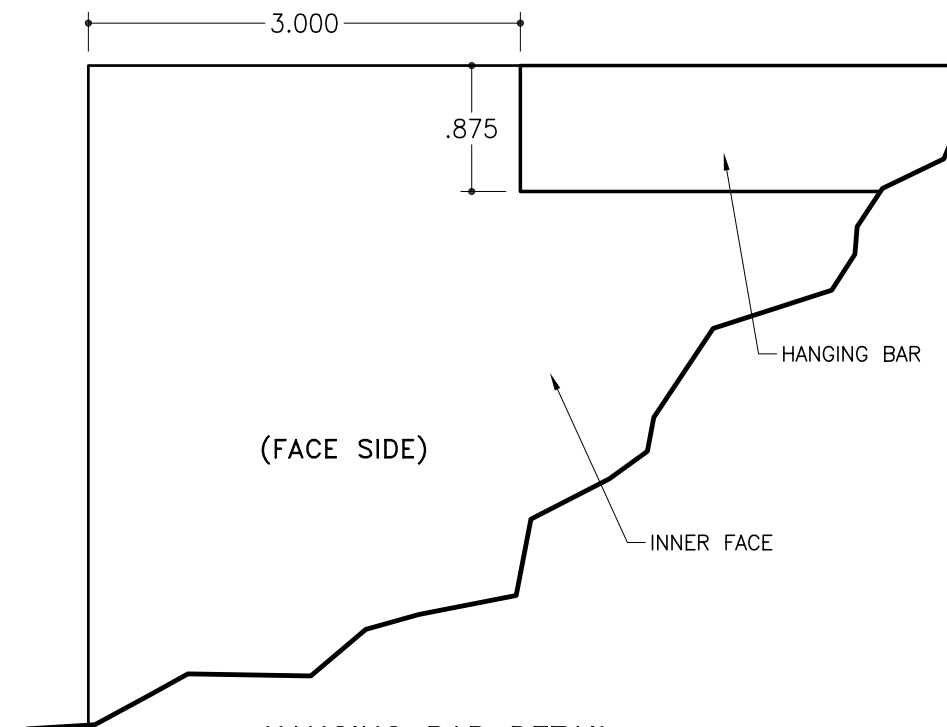

A HANGING BAR DETAIL

SCALE : 3/4" = 1"

SC-47 for Rigid Faces - Corner Assembly

- Single Face Body
Part #2025
- Inner Frame Retainer
Part #2099
- 2Part Outer Frame
Part #1942

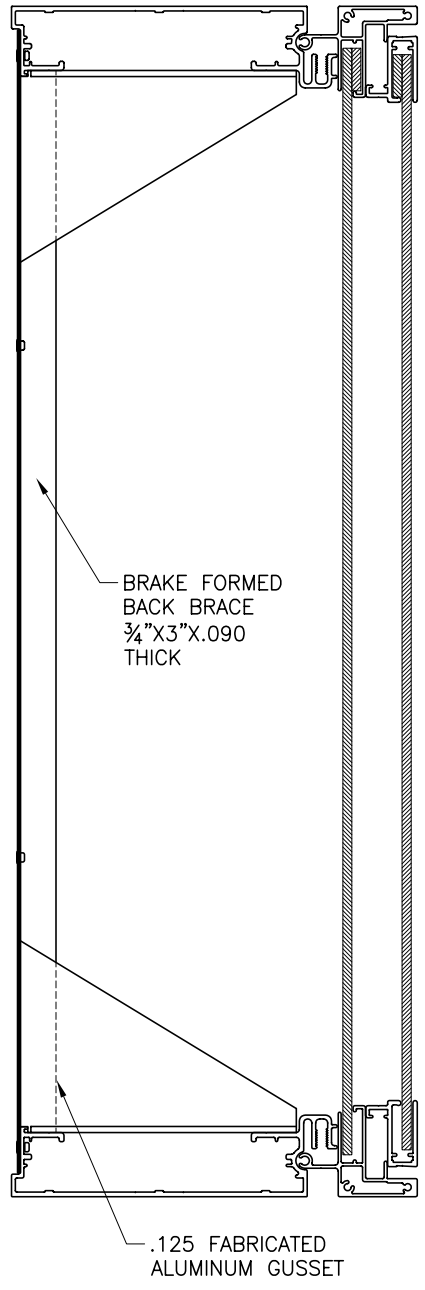

FULL SECTION
SCALE : 3" = 1"

NOTE:
SignComp does not supply the gussets or back braces.

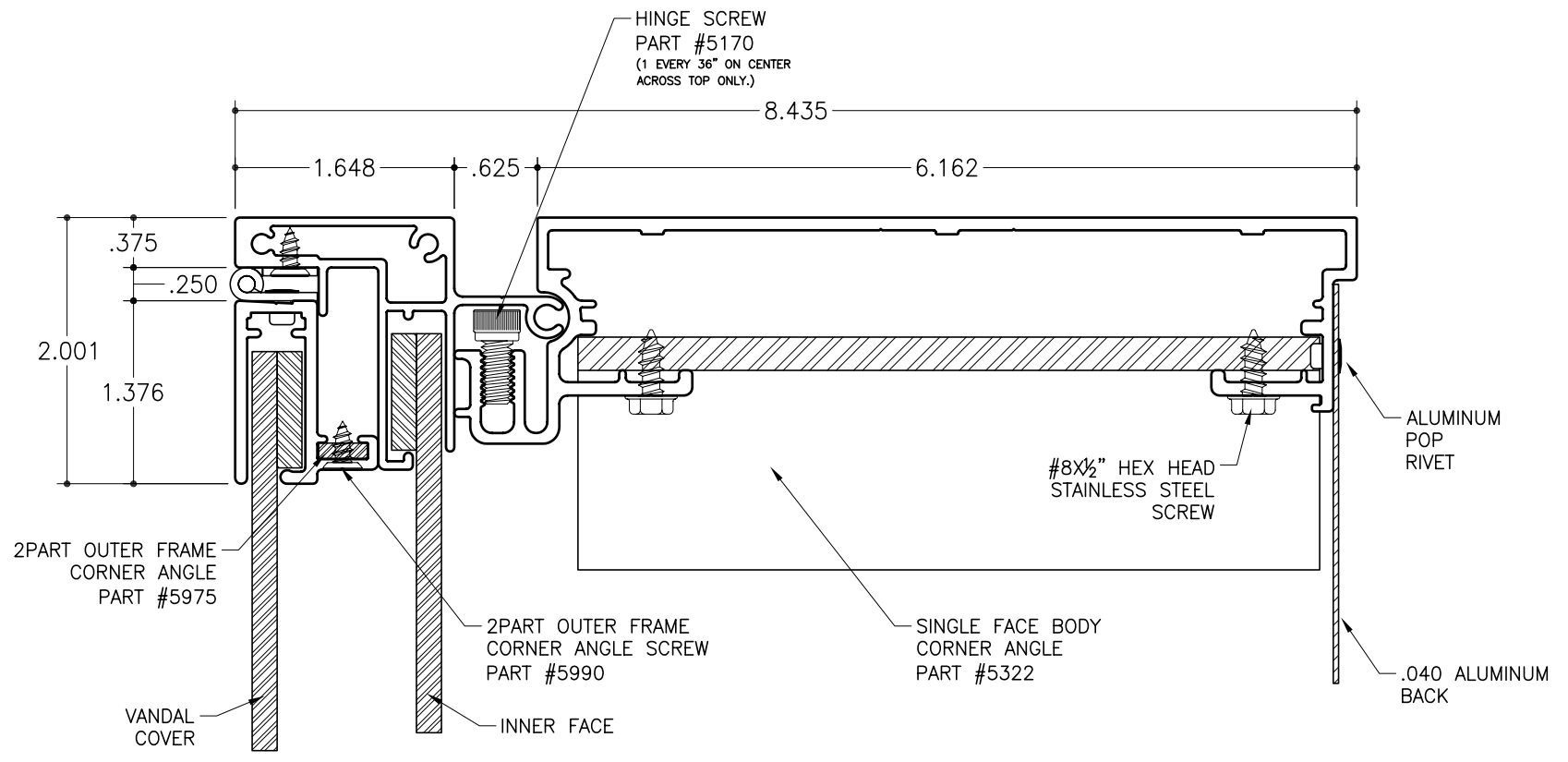

SECTION DETAIL
SCALE : 3/4" = 1"

- NOTES:
1. Add 1" to size of cabinet (vertical or horizontal) when the size of the cabinet is the same as the nominal lamp length.
 2. SignComp does not supply the ballast's, lamps, or lamp sockets.
 3. The 2Part Outer Frame to be cut 7/8" less than the overall width and 1-1/8" less than the overall height when it is hinged at the top. If hinging from the side is required then the 2Part Outer Frame is to be cut 1-1/8" less than the overall with and 7/8" less than the overall height.
 4. Inner Face hanging bar is to be places 3" in from edges of cut to size face, this will allow the hanging bar to clear the corner keys. The hanging bar is to be attached to the face side of the face.
 5. Hinge screws are to be 2"-3" on center the first 16" in from each end the remainder is to be placed 4"-6" apart.

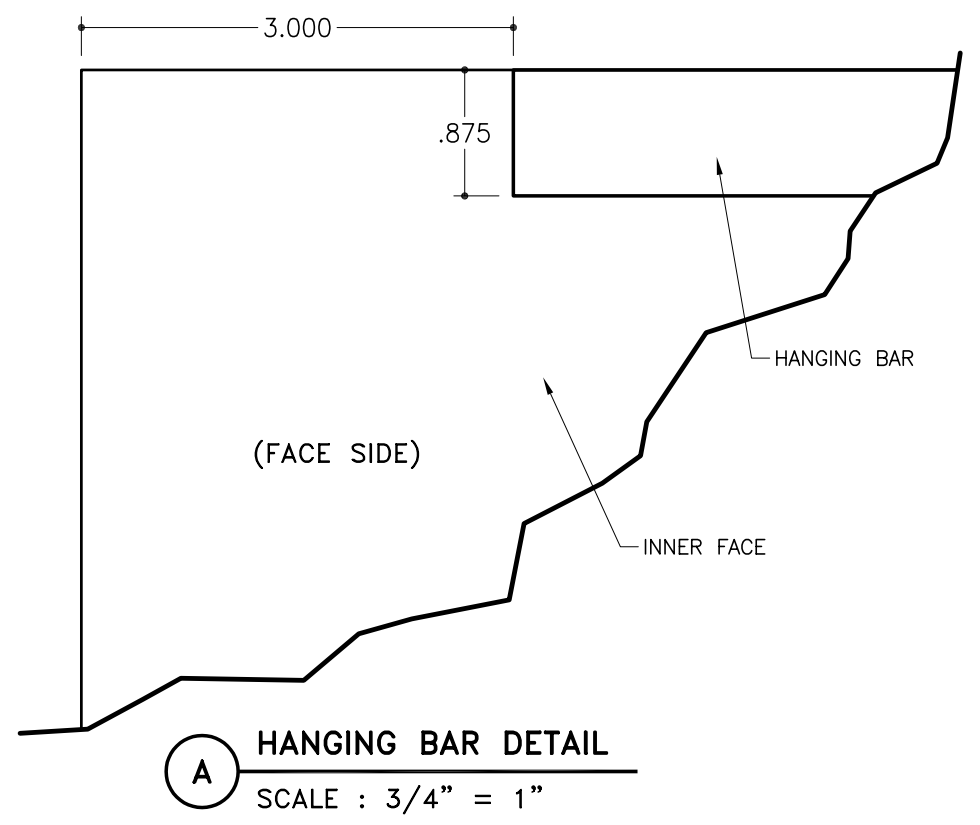

SC-47 for Rigid Faces – Lock Placement

Single Face Body
Part #2025

Inner Frame Retainer
Part #2099

2Part Outer Frame
Part #1942

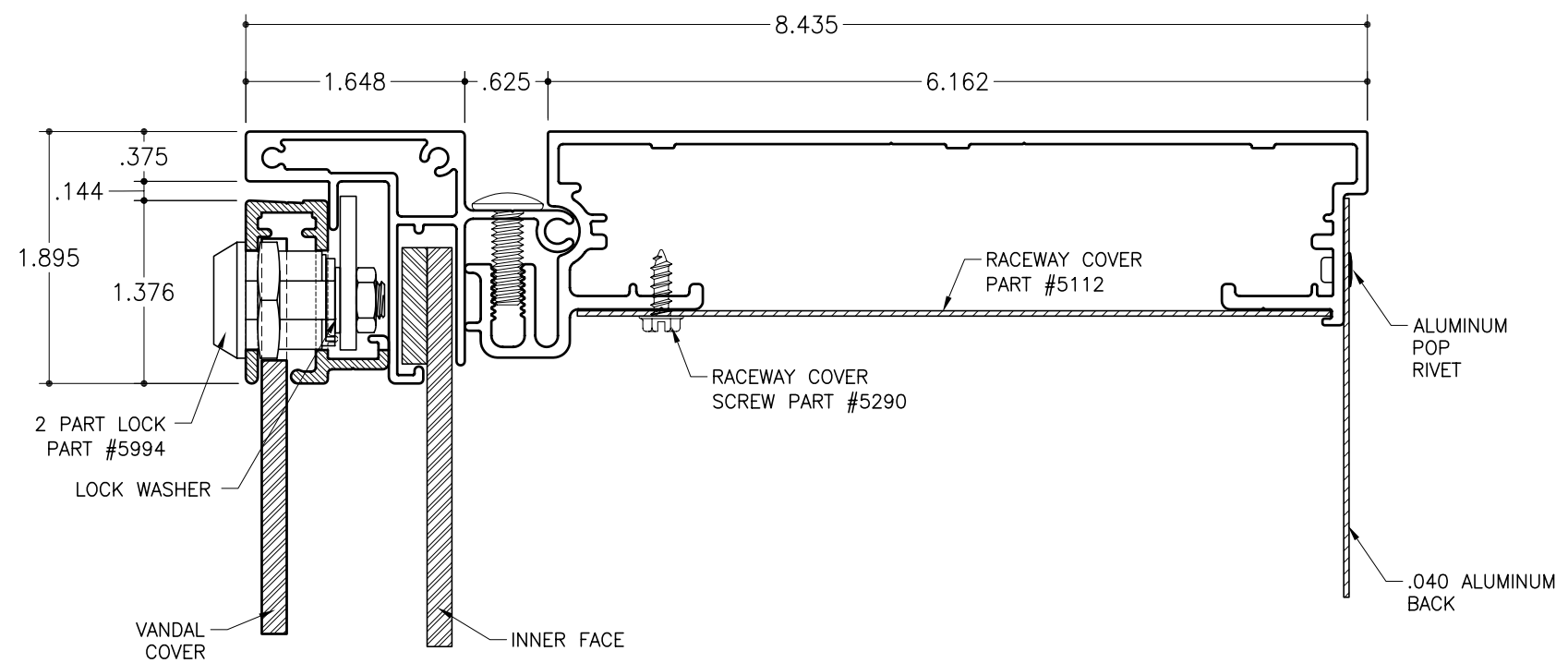

A SIDE SECTION DETAIL
SCALE : 3/4"=1"

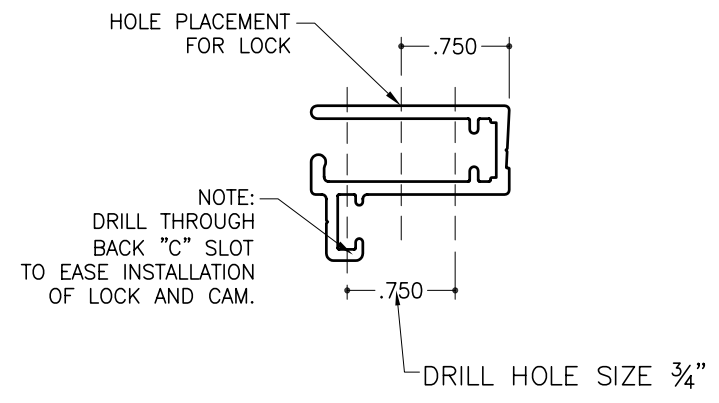

LOCK HOLE PLACEMENT
SCALE : 3/4"=1"

NOTES:

- Locks can be placed on the side or bottom frame(s), as a guide line for placement of the locks times the height/width in feet by 3 this will give you the distance in inches for the lock placement on the 2 Part Outer Frame.

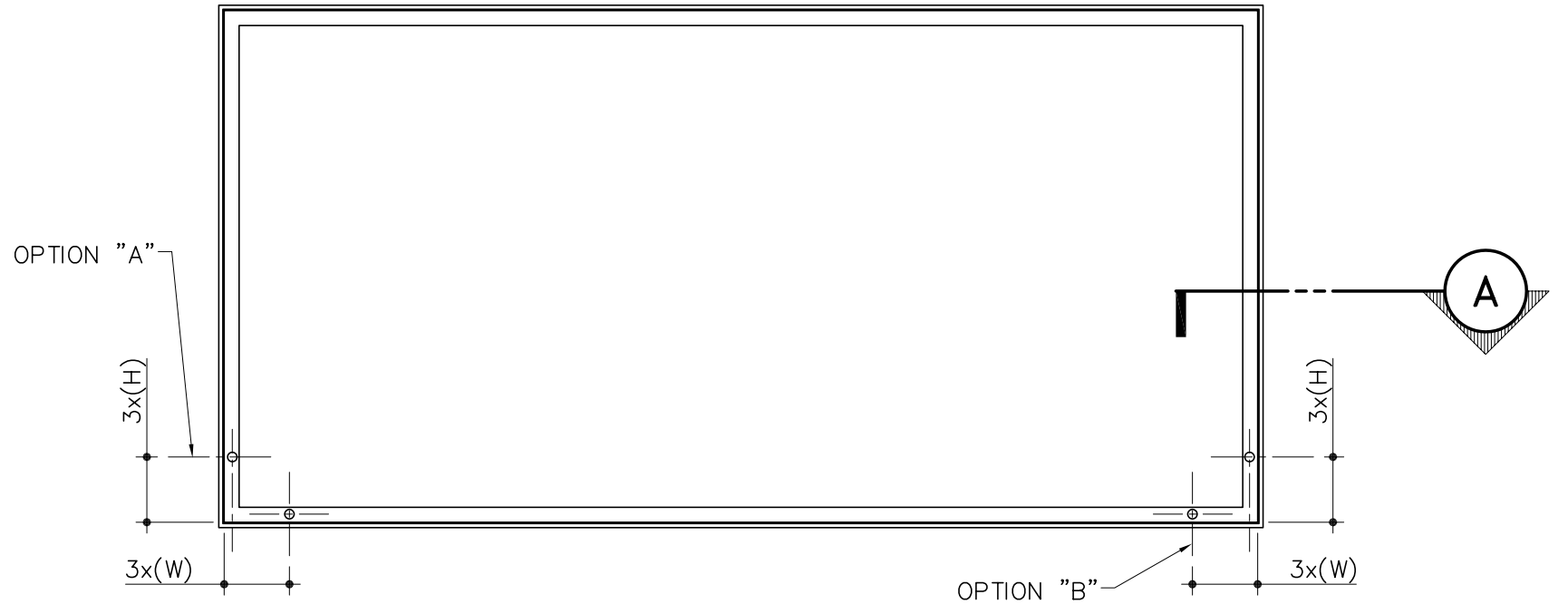

LOCK PLACEMENT
SCALE : 3/4"=1"

OPTION "A":
LOCKS ON SIDE.

OPTION "B":
LOCKS ON BOTTOM

SC-47 for Rigid Faces – Outer Frame Corner Assembly

Single Face Body
Part #2025

Inner Frame Retainer
Part #2099

2Part Outer Frame
Part #1942

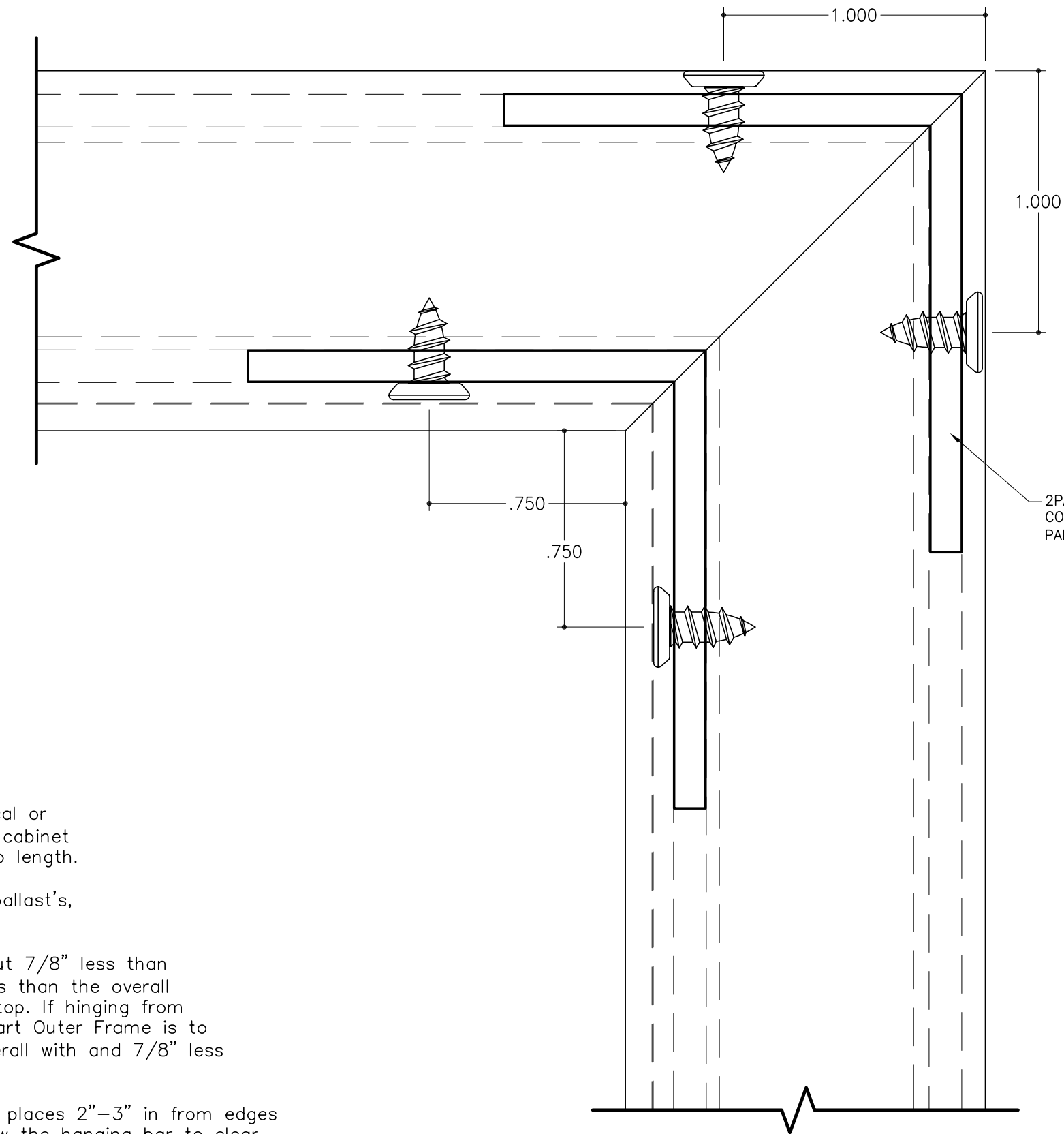

2PART OUTER FRAME CORNER SECTION

SCALE : 2"=1"

2 PART OUTER FRAME
CORNER ANGLE SCREW
#8x3/8" PHILLIPS HEAD (SS)
PART #5990

2PART OUTER FRAME
CORNER ANGLE
PART #5975

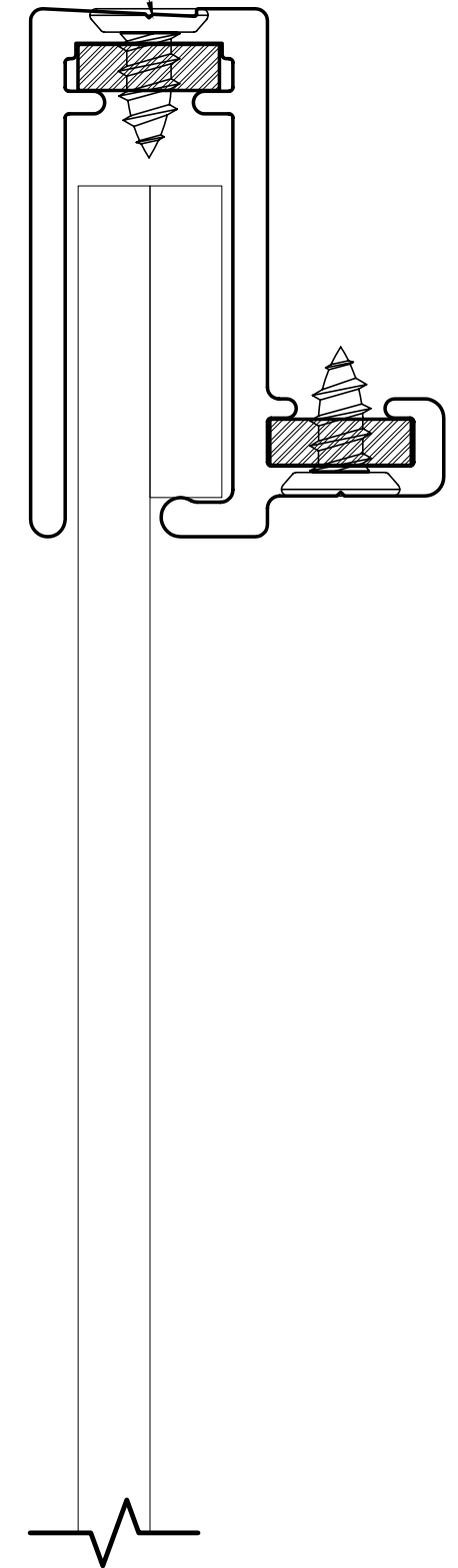

CORNER SECTION

SCALE : 2"=1"

NOTES:

1. Add 1" to size of cabinet (vertical or horizontal) when the size of the cabinet is the same as the nominal lamp length.
2. SignComp does not supply the ballast's, lamps, or lamp sockets.
3. The 2Part Outer Frame to be cut 7/8" less than the overall width and 1-1/8" less than the overall height when it is hinged at the top. If hinging from the side is required then the 2Part Outer Frame is to be cut 1-1/8" less than the overall width and 7/8" less than the overall height.
4. Inner Face hanging bar is to be placed 2"-3" in from edges of cut to size face, this will allow the hanging bar to clear the corner keys. The hanging bar is to be attached to the face side of the face.
5. Hinge screws are to be 3" on center the first 16" in from each end the remainder is to be placed 4"-6" apart.