

STD-3 for Rigid Faces - Electrical

1 Part 12" Body
 Part #1924

2 Part 12" Body
 Part #1929

2 Part Retainer
 Part #1944

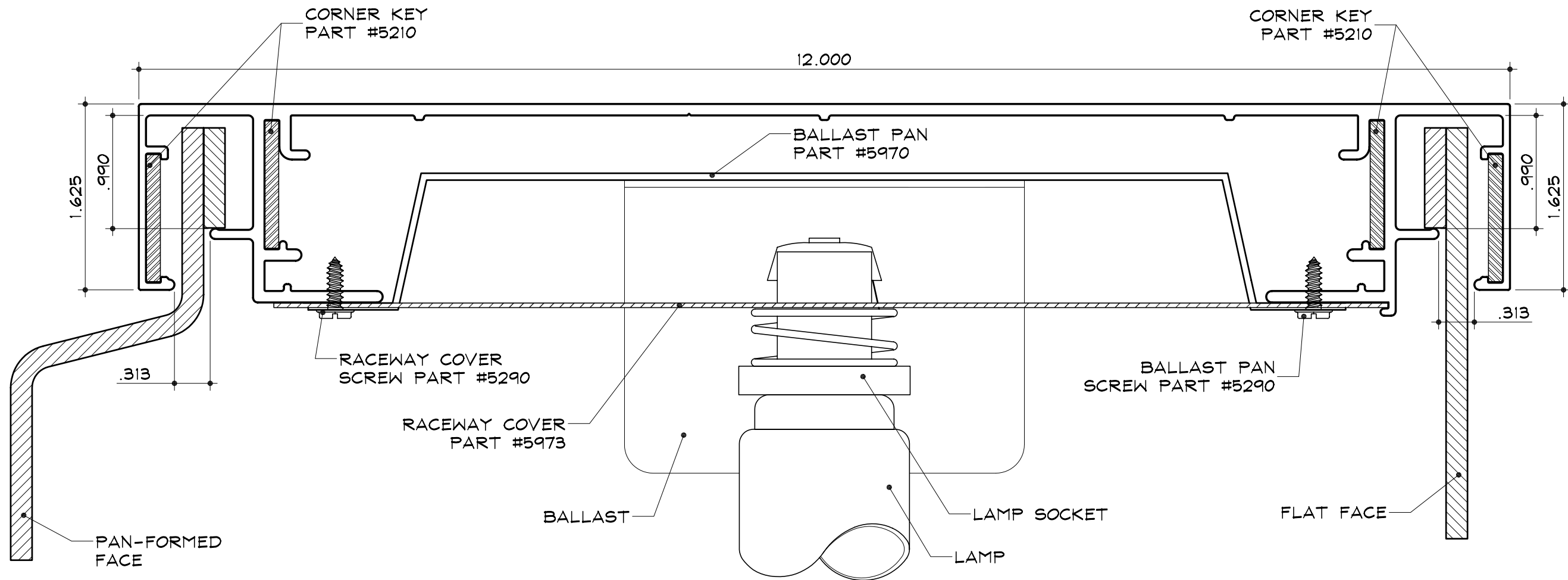

SECTION DETAIL (ELECTRICAL)

SCALE : 1" = 1"

NOTES:

1. Add 1/2" to 3/4" to size of cabinet (vertical or horizontal) when the size of the cabinet is the same as the nominal lamp length.
2. SignComp does not supply the Ballast(s), Lamps, Lamp Sockets.

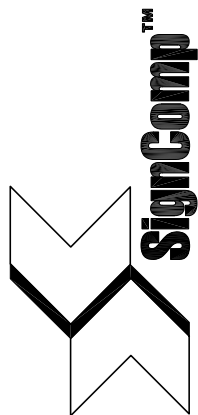

STD-3 for Rigid Faces - Structural (Corner)

1 Part 12" Body
 Part #1924

2 Part 12" Body
 Part #1929

2 Part Retainer
 Part #1944

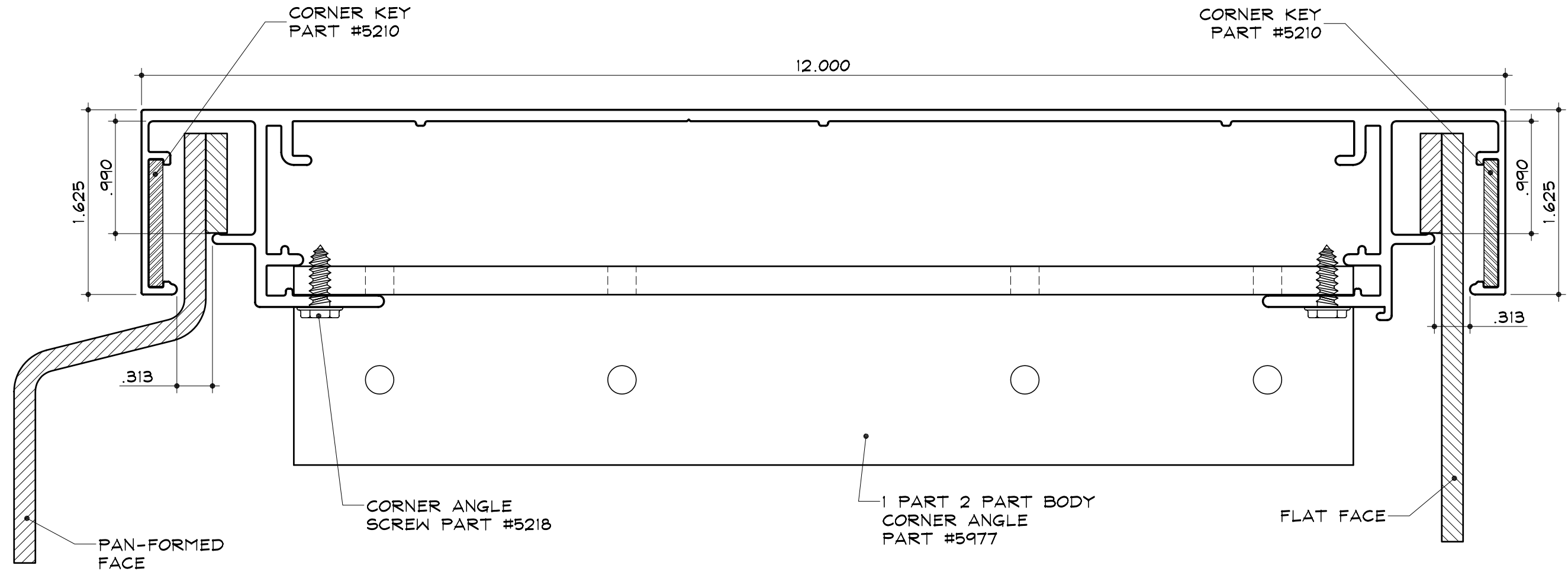

CORNER SECTION DETAIL (MECHANICALLY FASTENED CORNER ANGLE)

SCALE : 1" = 1"

NOTES:

1. Add $\frac{1}{2}$ " to $1\frac{3}{4}$ " to size of cabinet (vertical or horizontal) when the size of the cabinet is the same as the nominal lamp length.

STD-3 for Rigid Faces - Structural (Corner)

1 Part 12" Body
 Part #1924

2 Part 12" Body
 Part #1929

2 Part Retainer
 Part #1944

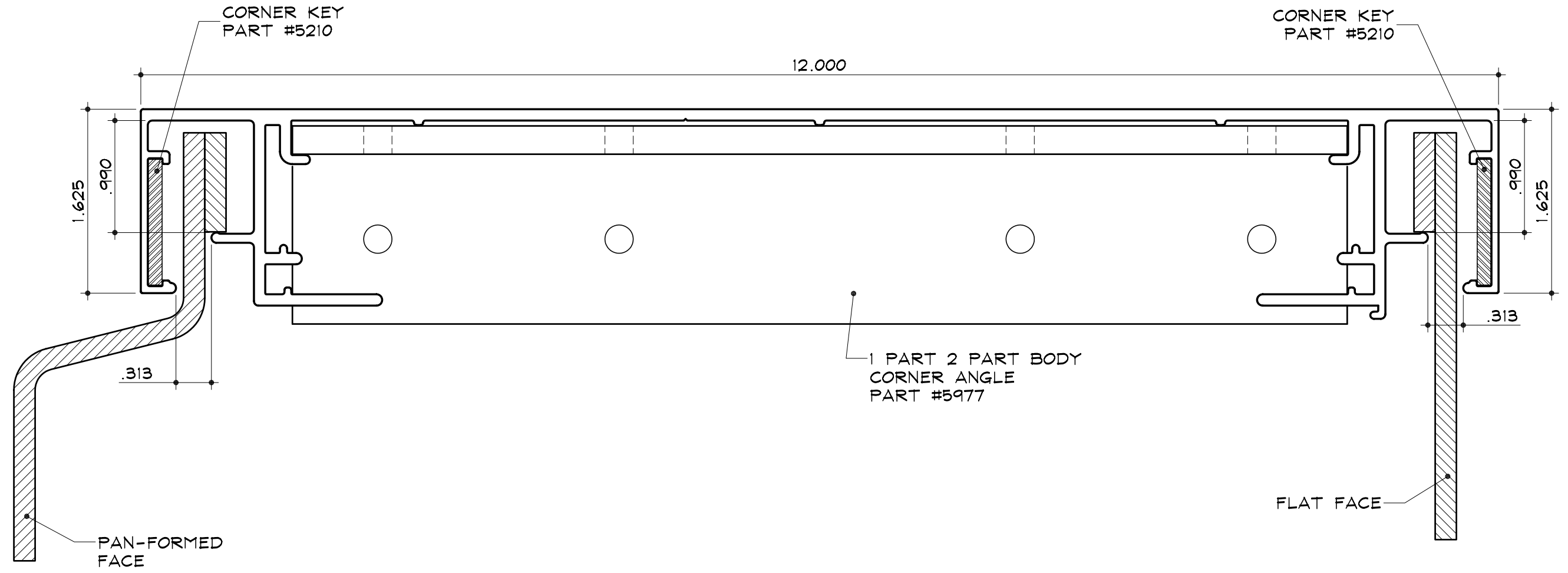

CORNER SECTION DETAIL (GLUED CORNER ANGLE)

SCALE : 1" = 1"

NOTES:

1. Add 1/2" to 3/4" to size of cabinet (vertical or horizontal) when the size of the cabinet is the same as the nominal lamp length.

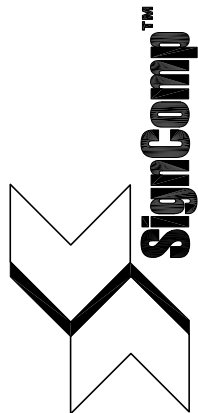

STD-3 for Rigid Faces - Structural (Corner)

1 Part 12" Body
 Part #1924

2 Part 12" Body
 Part #1929

2 Part Retainer
 Part #1944

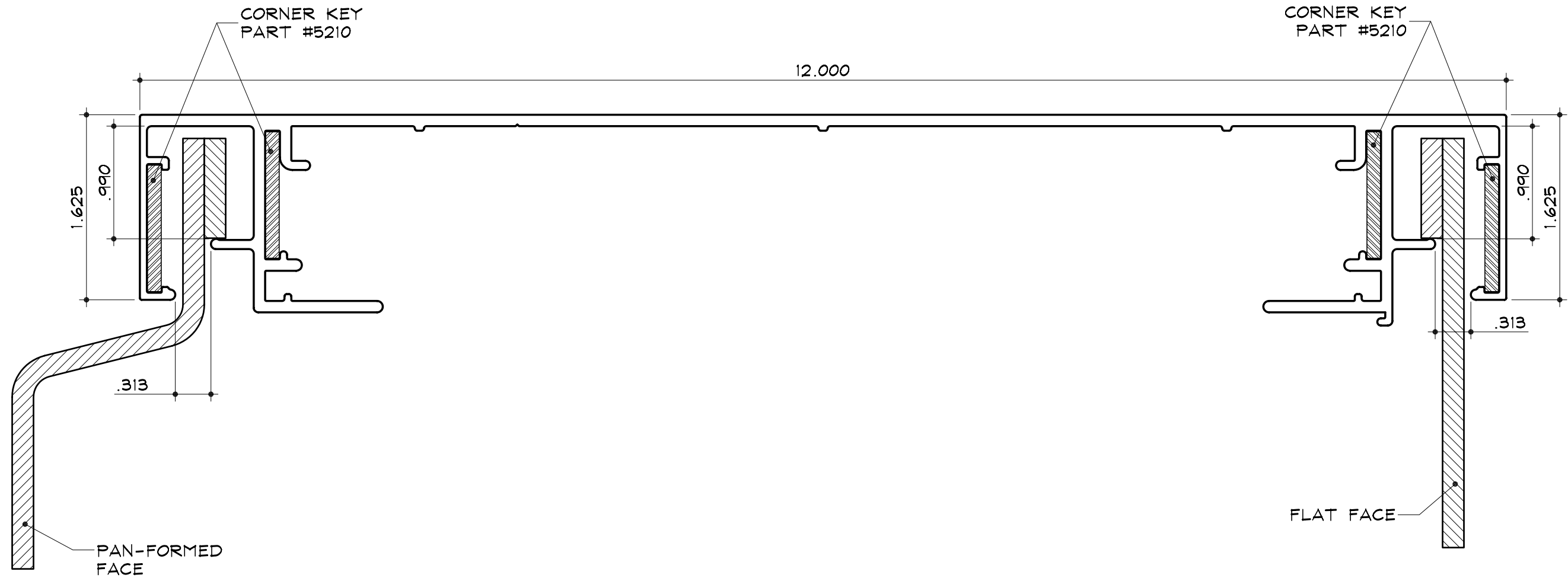

CORNER SECTION DETAIL (WELDED/CORNER KEYS)

SCALE : 1" = 1"

NOTES:

1. Add 1/2" to 1 3/4" to size of cabinet (vertical or horizontal) when the size of the cabinet is the same as the nominal lamp length.

STD-3 for Rigid Faces - Structural (Support)

1 Part 12" Body
 Part #1924

2 Part 12" Body
 Part #1929

2 Part Retainer
 Part #1944

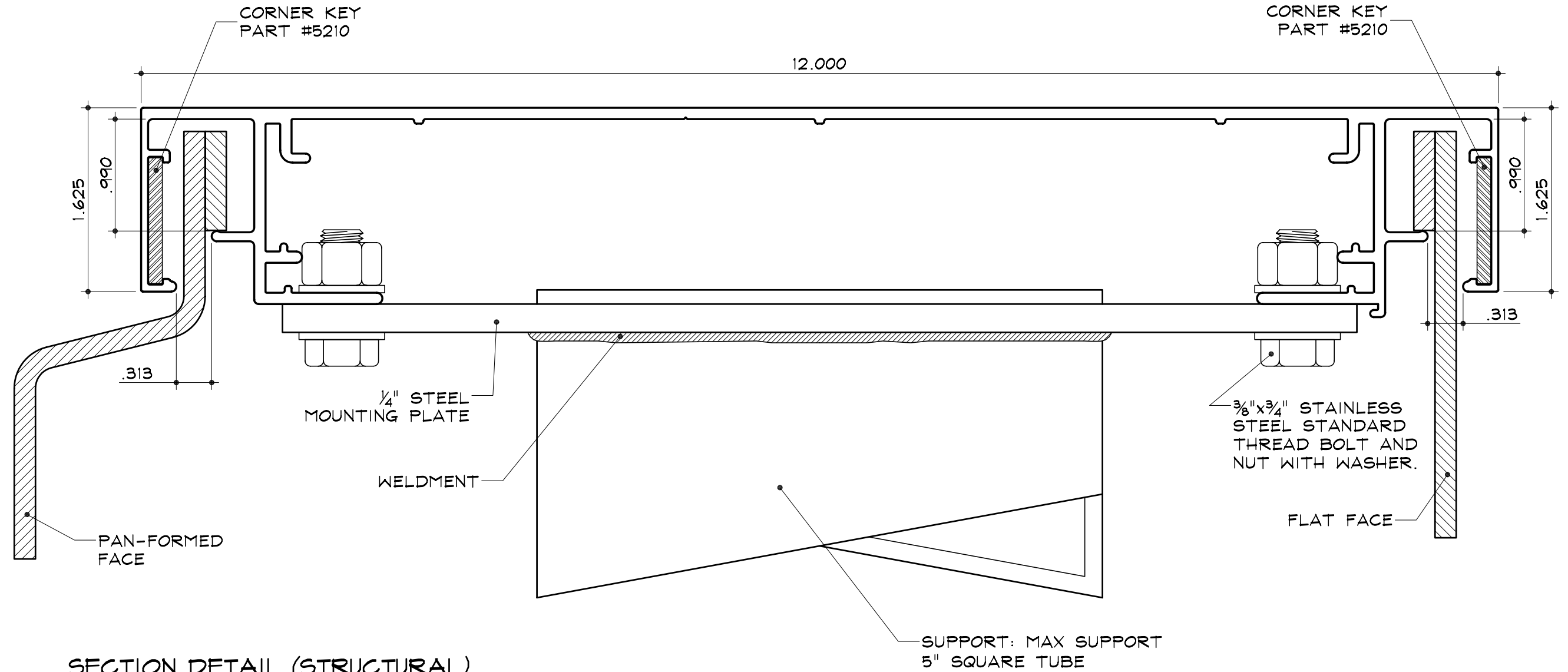

SECTION DETAIL (STRUCTURAL)

SCALE : 1" = 1"

NOTES:

1. Add 1/2" to 1 3/4" to size of cabinet (vertical or horizontal) when the size of the cabinet is the same as the nominal lamp length.
2. SignComp does not supply the 1/4" Mounting Plates, Mounting Hardware or Support.

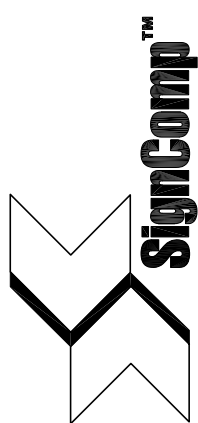

STD-3 for Rigid Faces - Side

1 Part 12" Body
 Part #1924

2 Part 12" Body
 Part #1929

2 Part Retainer
 Part #1944

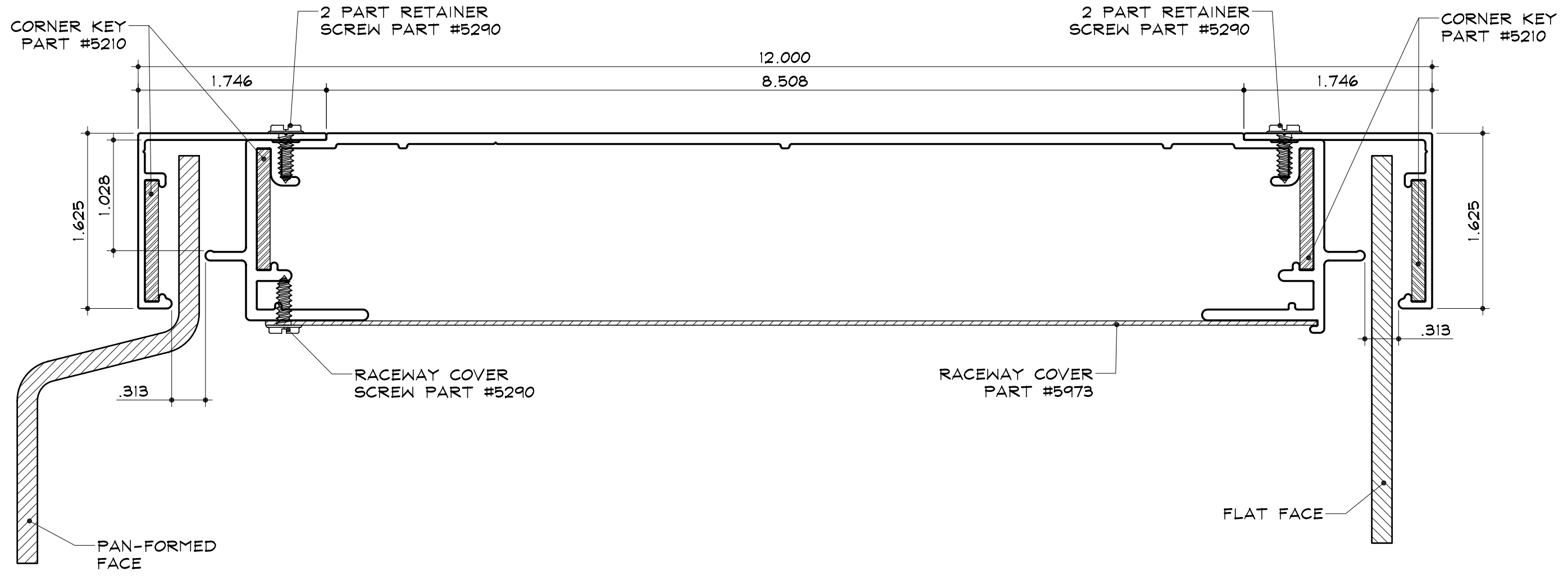

SIDE SECTION DETAIL

SCALE : 1" = 1"

NOTES:

1. Add 1/2" to 3/4" to size of cabinet (vertical or horizontal) when the size of the cabinet is the same as the nominal lamp length.

