

SC-2 for Rigid Faces - Electrical

Single Face Body  
 Part #2025

2 1/4" Retainer  
 Part #2045

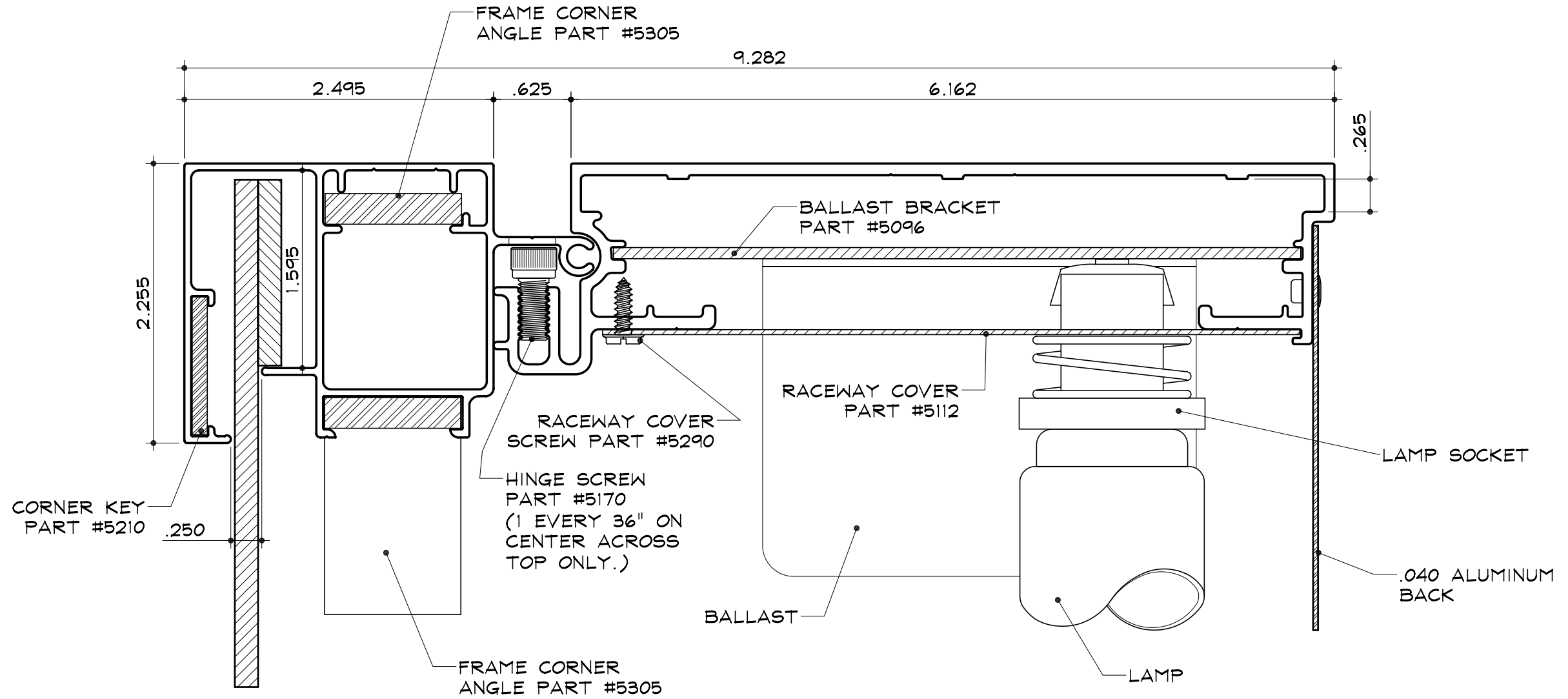

**SECTION DETAIL**

SCALE : 1" = 1"

**NOTES:**

1. Add 1" to size of cabinet (vertical or horizontal) when the size of the cabinet is the same as the nominal lamp length.
2. SignComp does not supply the Ballast(s), Lamps, Lamp Sockets or the .040 Aluminum Back.

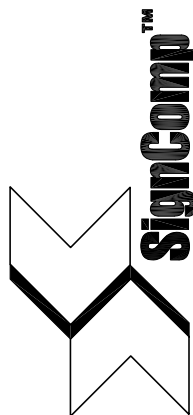

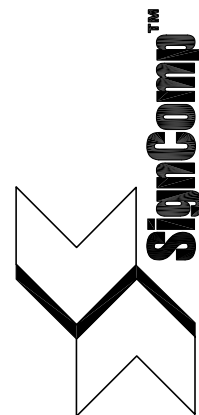

SC-2 for Rigid Faces - Side View

Single Face Body  
Part #2025

Dual Frame  
Part #2065

2 1/4" Dual Frame Cover  
Part #2075

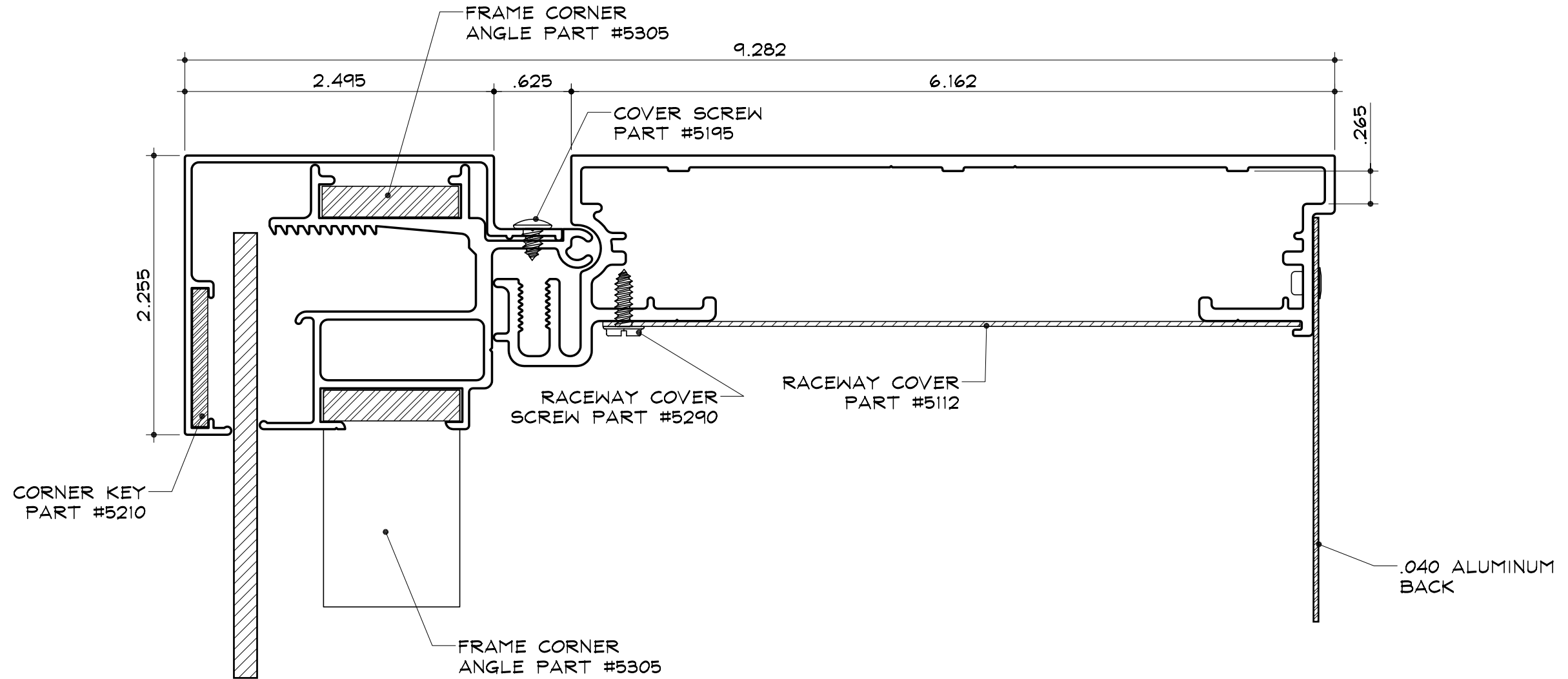

**SECTION DETAIL**

SCALE : 1" = 1"

NOTES:

1. Add 1" to size of cabinet (vertical or horizontal) when the size of the cabinet is the same as the nominal lamp length.
2. SignComp does not supply the .040 Aluminum Back.

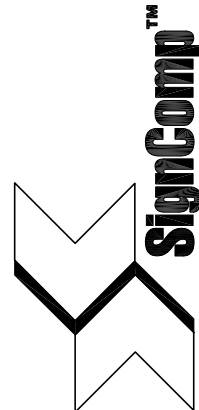

SC-2 for Rigid Faces - Structural

Single Face Body  
Part #2025

2 1/4" Retainer  
Part #2045

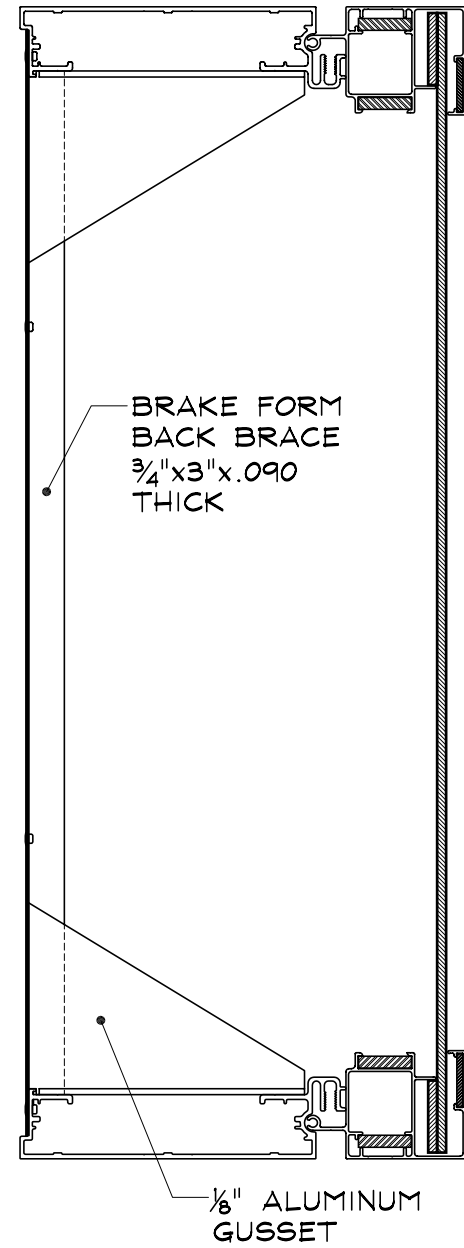

**FULL SECTION**

SCALE : 3" = 1"

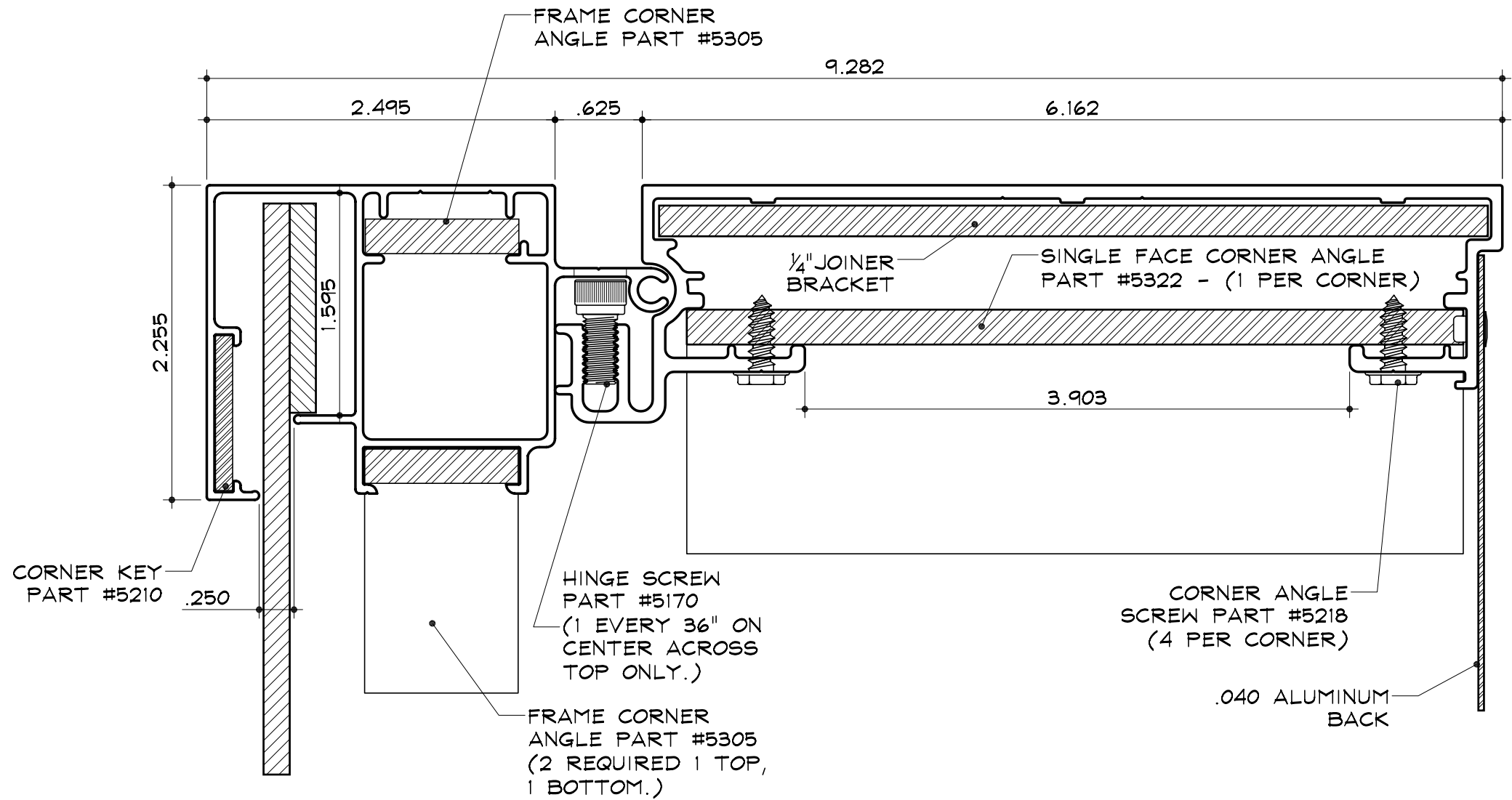

**SECTION DETAIL**

SCALE : 1" = 1"

NOTES:

1. Add 1" to size of cabinet (vertical or horizontal) when the size of the cabinet is the same as the nominal lamp length.
2. SignComp does not supply the Material for Gussets, 1/4" Joiner Bracket, or .040 Aluminum Back.