

2



1

PARTS LIST

ITEM	PART #	DESCRIPTION	NOTES
1	2008	Flat Double Face Body	Assembly
2	2047	Flat 2" Retainer	Assembly
79	5178	Hinge Screw - #10 x 5/8" pancake head	Pre-drill 5/32" pilot hole every 36" - Top only
80	5178	Closure Screw - #10 x 5/8" pancake head	Pre-drill 5/32" pilot hole every 48" - Sides & Bottom

NOTE: PRE-CUT KITS ARE NOT PRE-DRILLED.

(Holes shown in this drawing are for reference only.
Drilling of pilot holes are to be done by fabricator.)

B

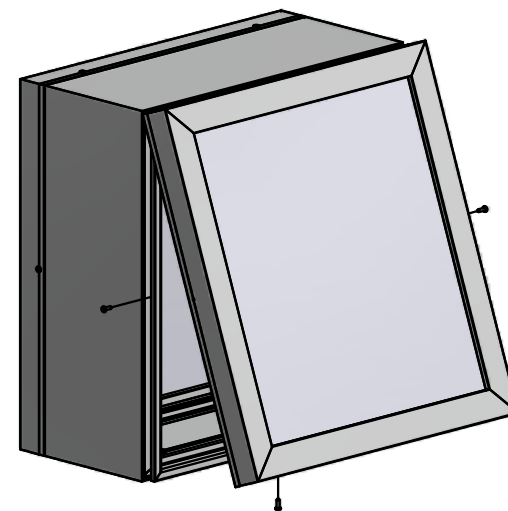
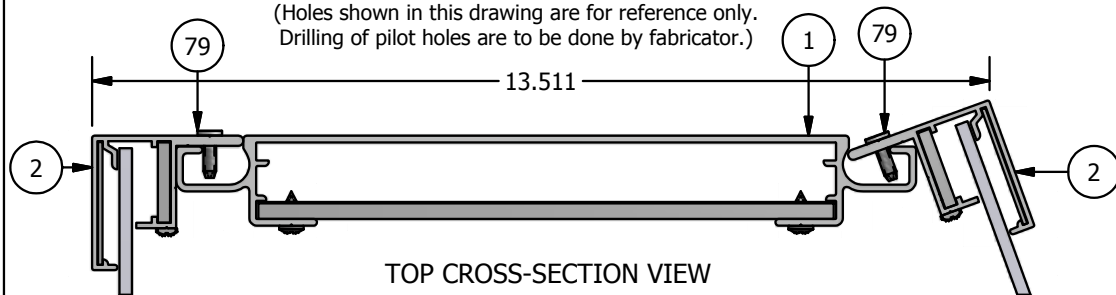

A

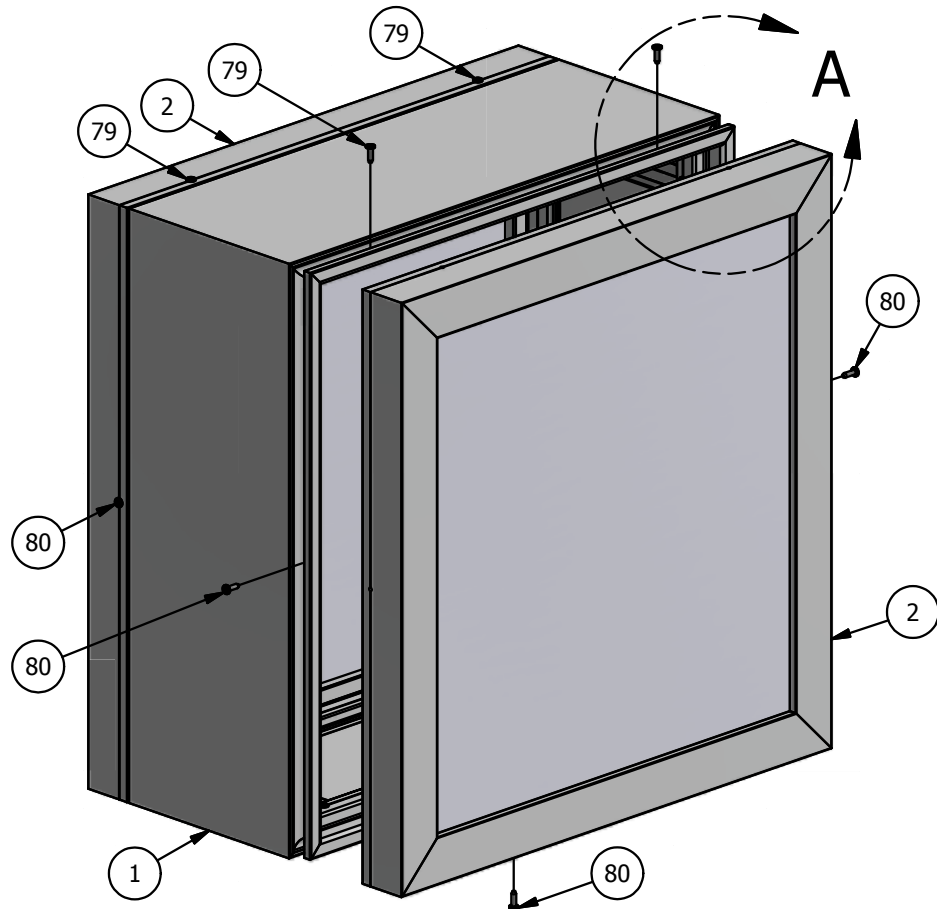

A

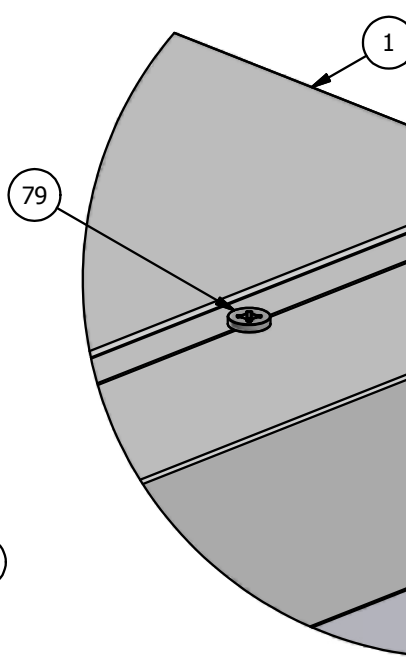

DETAIL A

Ship To:
Sales Order #

2



1

THIS DRAWING WAS CREATED AT NO CHARGE TO ASSIST YOU IN VISUALIZING OUR PROPOSAL. THE DRAWING HEREIN IS THE PROPERTY OF SIGNCOMP. PERMISSION TO COPY OR REVISE THIS DRAWING OR TO USE THIS DRAWING FOR PRODUCTION IS STRICTLY PROHIBITED AND CAN ONLY BE COPIED, REVISED OR USED FOR PRODUCTION WITH THE EXPRESSED WRITTEN PERMISSION OF SIGNCOMP.

Part Name: Flat Double Face Body & Flat 2" Ret. - Assembly

Part Number: K2008/2047

Date: 6/2/2015

Drawing By: SBreihof

Sheet: 1 of 1

Size:

A

1

SignComp

A

B

PARTS LIST			
ITEM	PART #	DESCRIPTION	NOTES
1	2008	Flat Double Face Body	Top & Bottom
2	2008	Flat Double Face Body	Sides
3	5908	Flat Double Face Body Corner Angle	One (1) per corner
13	5218	Corner Angle Screw	Pre-drill 5/32" pilot hole

Ship To:
Sales Order#

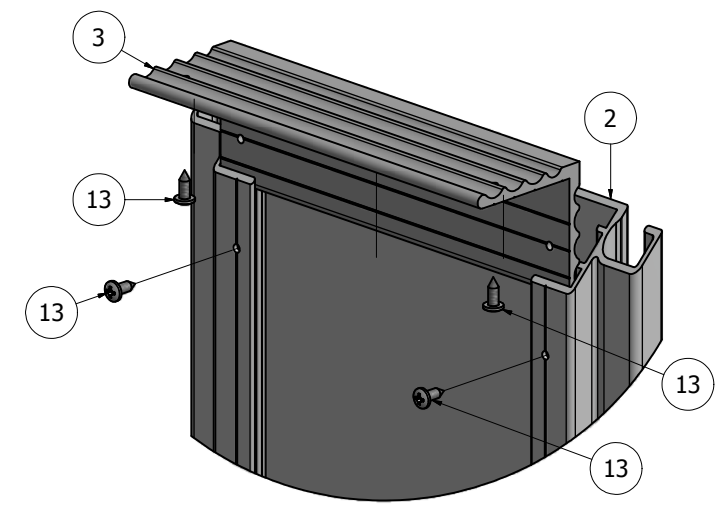
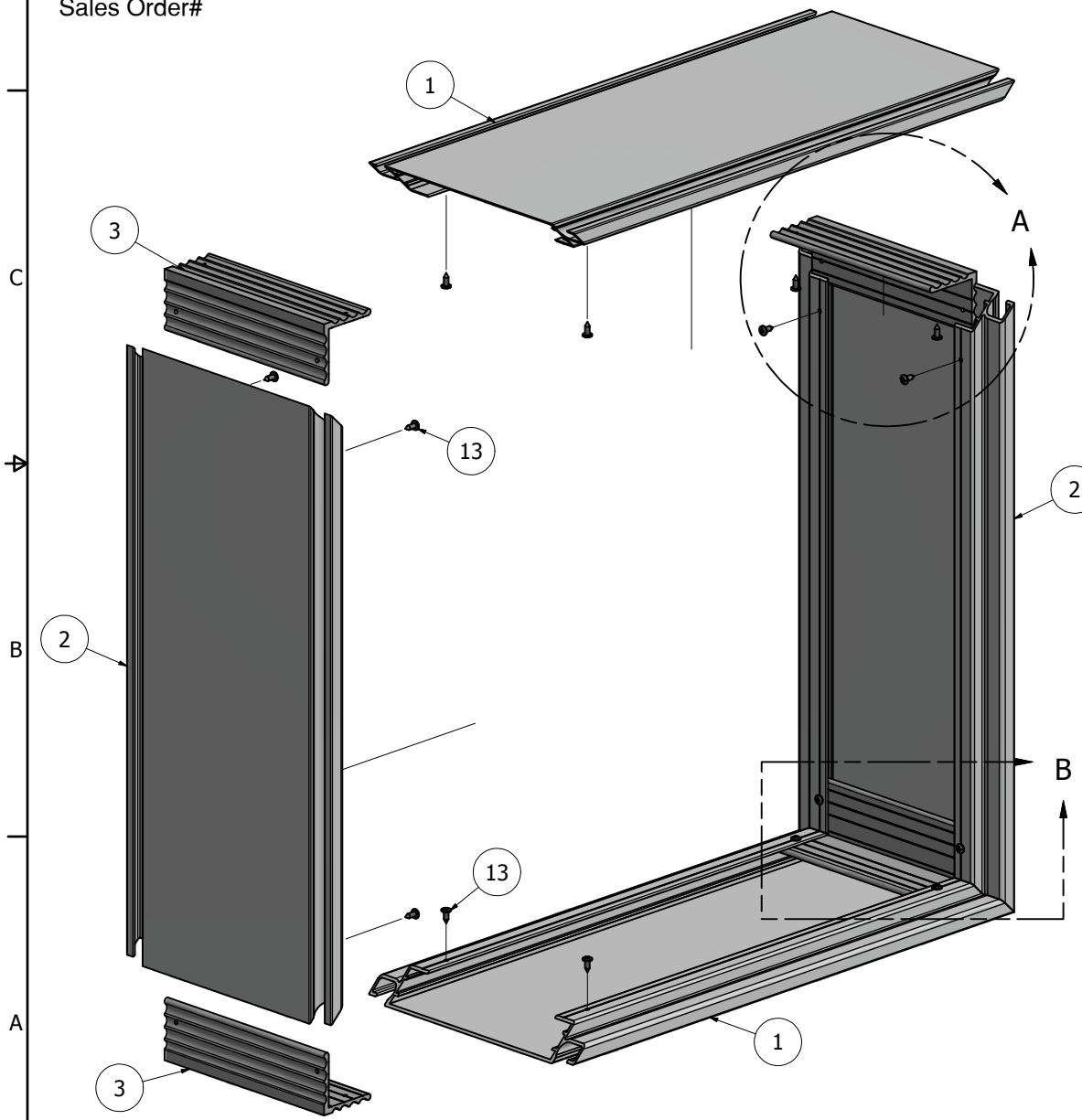

DETAIL A

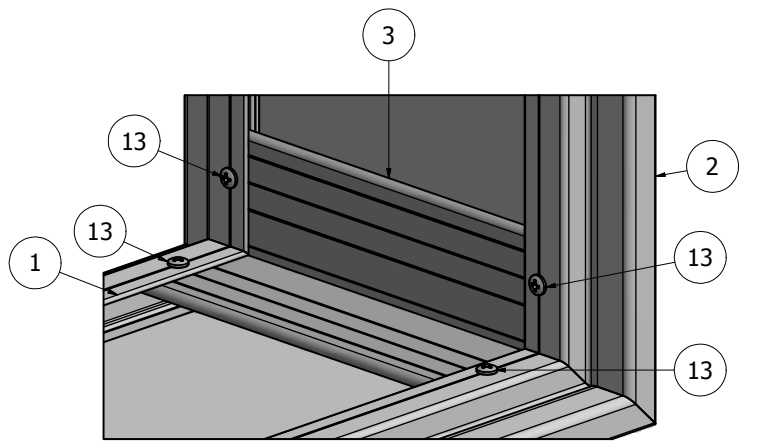

DETAIL B

NOTE: PRE-CUT KITS ARE NOT PRE-DRILLED.
(Holes shown in this drawing are for reference only.
Drilling of pilot holes are to be done by fabricator.)

DRAWING BY: SBreihof 8/14/2013		SignComp
Centroid X: 0.000 in	TITLE	
Centroid Y: 0.000 in	Flat Double Face Body - Assembly	
Principal Moments Ix: 0.000 in ⁴	PART NO	REV
Principal Moments Iy: 0.000 in ⁴	K2008	
Section Modulus Ix: 0.000 in ³	SHEET 1 OF 1	
Section Modulus Iy: 0.000 in ³		

2

PARTS LIST

ITEM	PART #	DESCRIPTION	NOTES
1	2047	Flat 2" Retainer	Top & Bottom Retainers
2	2047	Flat 2" Retainer	Sides
3	5214	Flat 2" Frame Corner Bracket	
4	5214	Flat 2" Frame Corner Key	
87	5195	Flat Frame Corner Bracket Screw	#8 x 5/16" - Pre-drill 1/8" holes Four (4) per corner

NOTE: PRE-CUT KITS ARE NOT PRE-DRILLED.

(Holes shown in this drawing are for reference only.
Drilling of pilot holes are to be done by fabricator.)

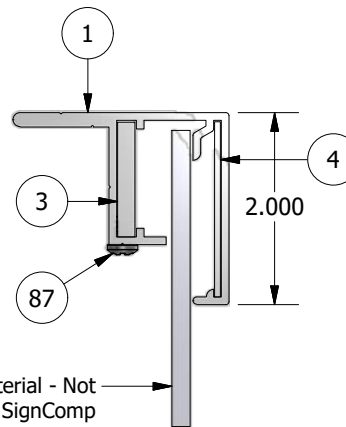

CROSS-SECTION VIEW

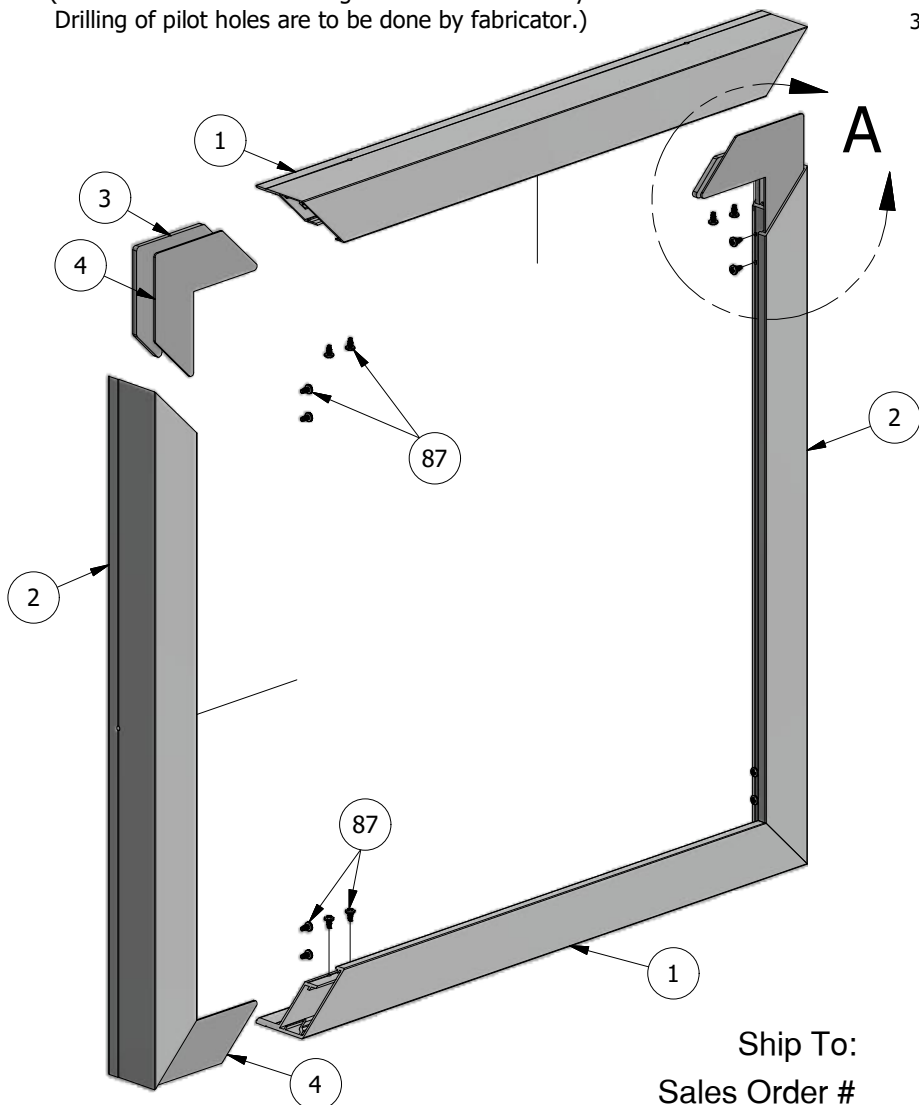
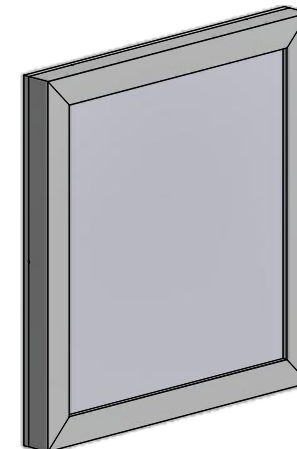

Ship To:
Sales Order #

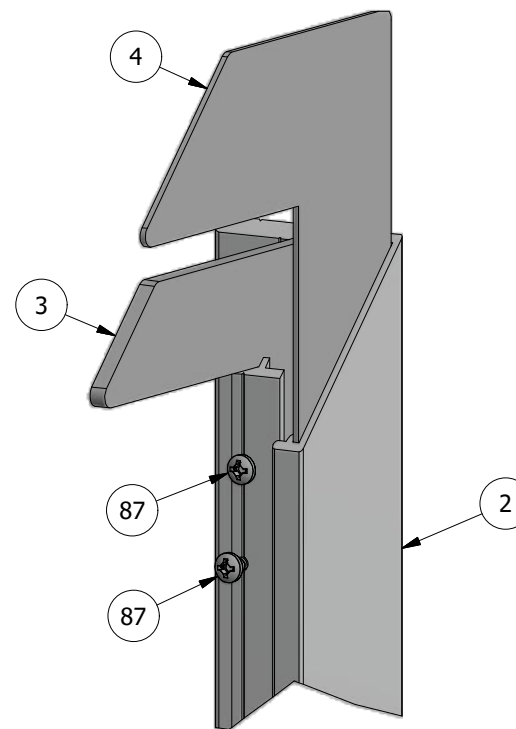

DETAIL A

THIS DRAWING WAS CREATED AT NO CHARGE TO ASSIST YOU IN VISUALIZING OUR PROPOSAL. THE DRAWING HEREIN IS THE PROPERTY OF SIGNCOMP. PERMISSION TO COPY OR REVISE THIS DRAWING OR TO USE THIS DRAWING FOR PRODUCTION IS STRICTLY PROHIBITED AND CAN ONLY BE COPIED, REVISED OR USED FOR PRODUCTION WITH THE EXPRESSED WRITTEN PERMISSION OF SIGNCOMP.

Part Name: Flat 2" Retainer

Part Number: 2047

Revision:

Date: 4/27/2015

Drawing By: SBreihof

Sheet: 1 of 1

Size: A

SignComp

A

B

2

1