

PARTS LIST			
ITEM	PART #	DESCRIPTION	NOTES
1	K2020	Slimline Single Face Body	Assembly
2	K2060/92	Commercial Access Frame/Insert Cover	Assembly
43	5170	Hinge Screw	Drill 3/8" pilot hole
44	5180	Closure Screw	Drill 5/16" pilot hole

Ship To:  
Sales Order#

DRIVE THE HINGE SCREW DOWN INTO THE BODY SO THE HEAD OF THE SCREW IS UNDER THE FRAME FLANGE AS SHOWN IN THE CROSS SECTION VIEW BELOW.

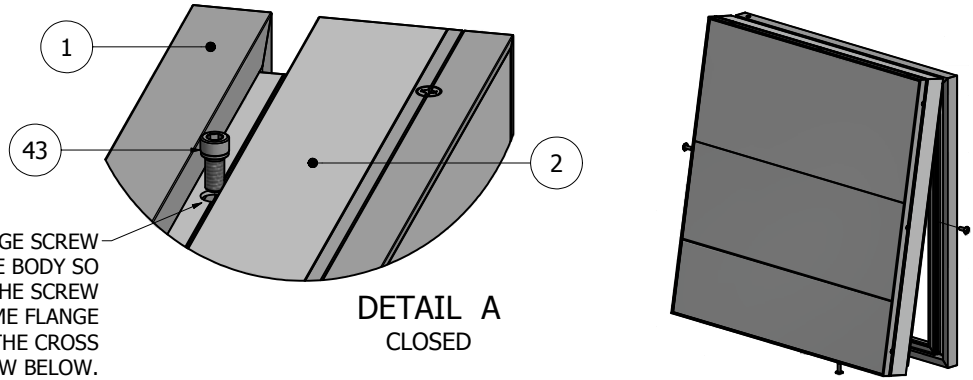

DETAIL A  
CLOSED

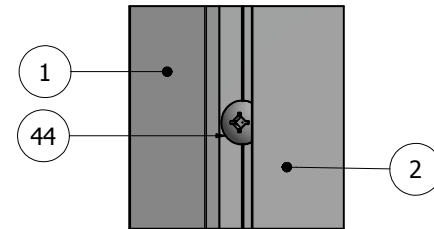
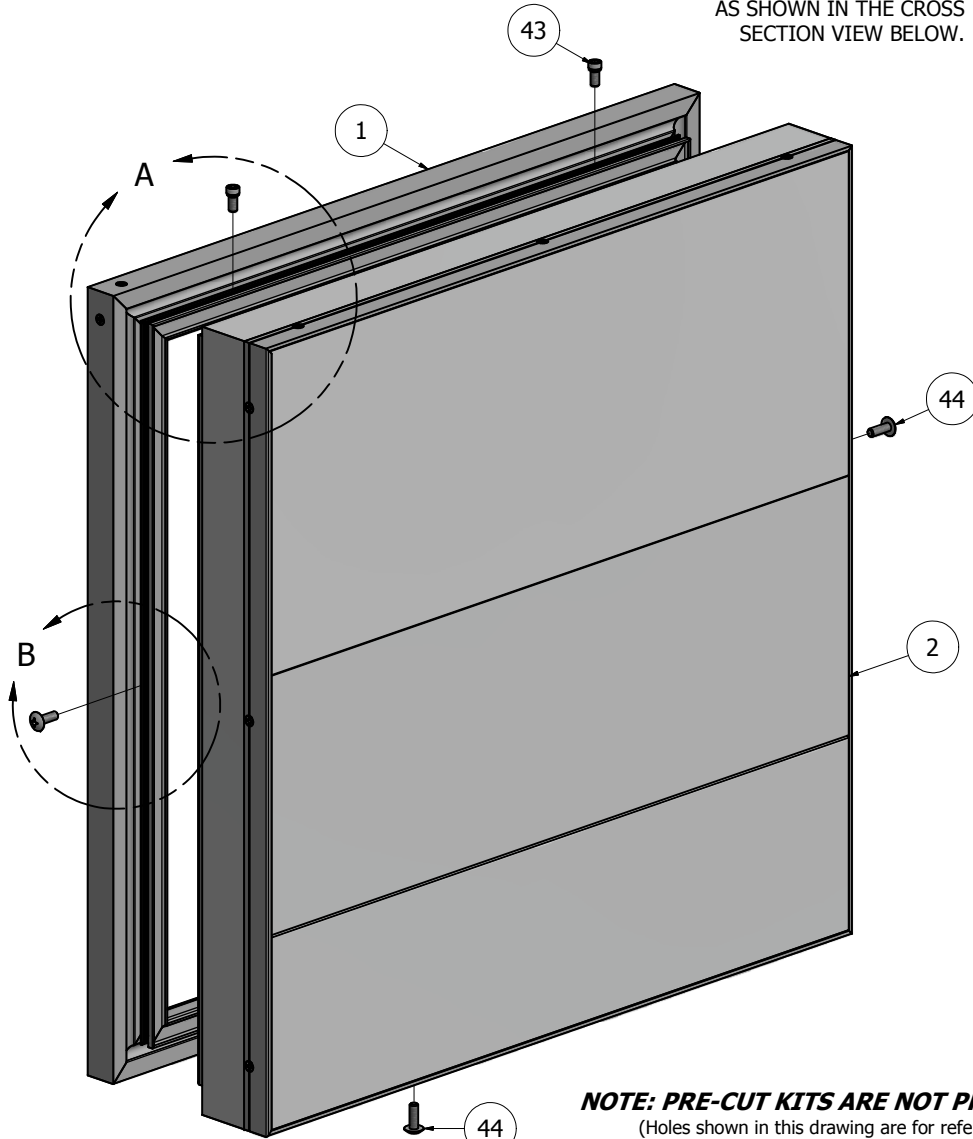

DETAIL B  
CLOSED

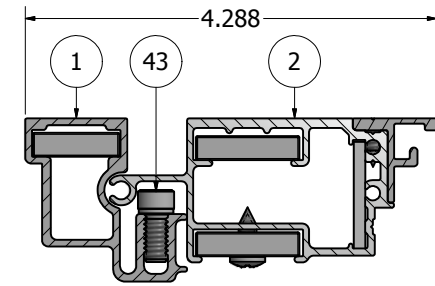

TOP CROSS-SECTION VIEW

THIS DRAWING WAS CREATED AT NO CHARGE TO ASSIST YOU IN VISUALIZING OUR PROPOSAL. THE DRAWING HEREIN IS THE PROPERTY OF SIGNCOMP. PERMISSION TO COPY OR REVISE THIS DRAWING OR TO USE THIS DRAWING FOR PRODUCTION IS STRICTLY PROHIBITED AND CAN ONLY BE COPIED, REVISED OR USED FOR PRODUCTION WITH THE EXPRESSED WRITTEN PERMISSION OF SIGNCOMP.

DRAWING BY:	SBreihof	6/11/2013
Centroid X:	0.000 in	
Centroid Y:	0.000 in	
Principal Moments Ix:	0.000 in^4	
Principal Moments Iy:	0.000 in^4	
Section Modulus Ix:	0.000 in^3	
Section Modulus Iy:	0.000 in^3	

<b>SignComp</b>		TITLE
		Slimline Single Face Body w/ Commercial Access Frame and Insert Cover - Assembly
PART NO	<b>K2020-60-92</b>	REV

**NOTE: PRE-CUT KITS ARE NOT PRE-DRILLED.**  
(Holes shown in this drawing are for reference only. Drilling of pilot holes are to be done by fabricator.)

Parts List			
ITEM	PART#	DESCRIPTION	NOTES
1	2020	Slimline Single Face Body	Top & Bottom
2	2020	Slimline Single Face Body	Sides
3	5320	Slimline Body Corner Angle	
4	By Other	Frame Angle Fastener - Optional	NOT PROVIDED BY SIGNCOMP

THIS AREA ALLOWS FOR ADHESIVE OR BONDING AGENT. ADHESIVE MUST BE APPLIED BEFORE THE ANGLE IS INSERTED.

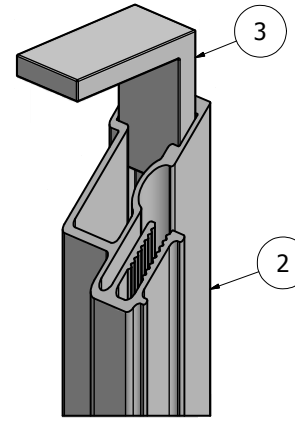
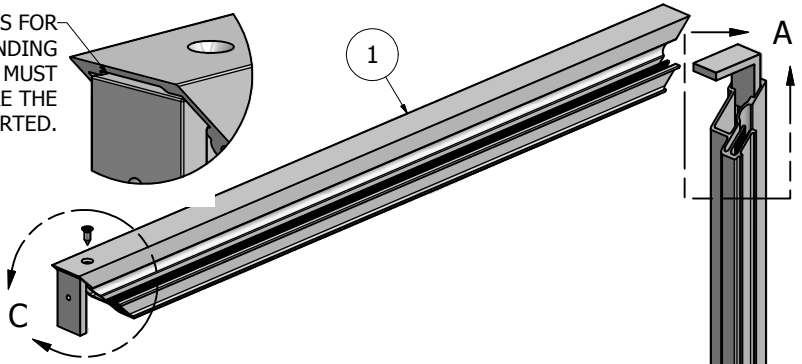
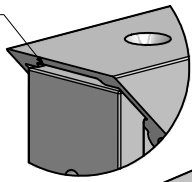

DETAIL A

Ship To:  
Order Number:

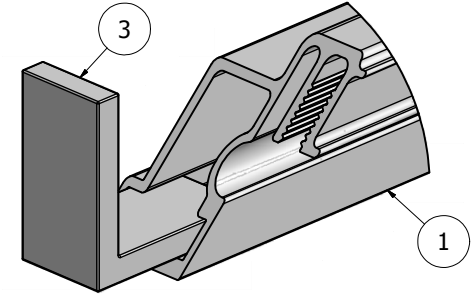

DETAIL B

\*OPTIONAL FASTENER-ASSEMBLY - FRAME IS DESIGNED TO BE BONDED OR WELDED.

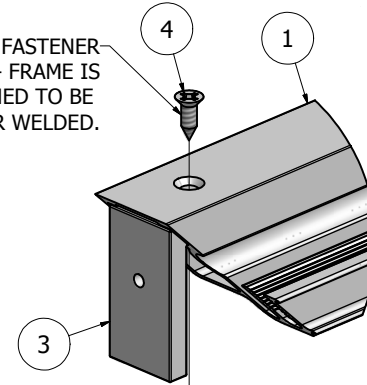

DETAIL C

**NOTE: PRE-CUT KITS ARE NOT PRE-DRILLED.**

(Holes shown in this drawing are for reference only. Drilling of pilot holes are to be done by fabricator.)

THIS DRAWING WAS CREATED AT NO CHARGE TO ASSIST YOU IN VISUALIZING OUR PROPOSAL. THE DRAWING HEREIN IS THE PROPERTY OF SIGNCOMP. PERMISSION TO COPY OR REVISE THIS DRAWING OR TO USE THIS DRAWING FOR PRODUCTION IS STRICTLY PROHIBITED AND CAN ONLY BE COPIED, REVISED OR USED FOR PRODUCTION WITH THE EXPRESSED WRITTEN PERMISSION OF SIGNCOMP.

DRAWN	Sarah	4/30/2012
Centroid X:	0.000 in	
Centroid Y:	0.000 in	
Principal Moments Ix:	0.000 in <sup>4</sup>	
Principal Moments Iy:	0.000 in <sup>4</sup>	
Section Modulus Ix:	0.000 in <sup>3</sup>	
Section Modulus Iy:	0.000 in <sup>3</sup>	

# SignComp

TITLE  
Slimline Single Face Body - Assembly

DWG NO

**K2020**

REV

PARTS LIST			
ITEM	PART #	DESCRIPTION	NOTES
1	2060	Commercial Access Frame	Top & Bottom Sides
2	2060	Commercial Access Frame	Sides
3	5210	Corner Key	
4	5305	Frame Corner Angle	
18	5218	Frame Corner Angle Screw	Pre-drill 5/32" hole
77	5241	Comm. Access Frame Corner Screw	See Detail C

Ship To:  
Sales Order#

D  
C  
B  
A

4 3 2 1

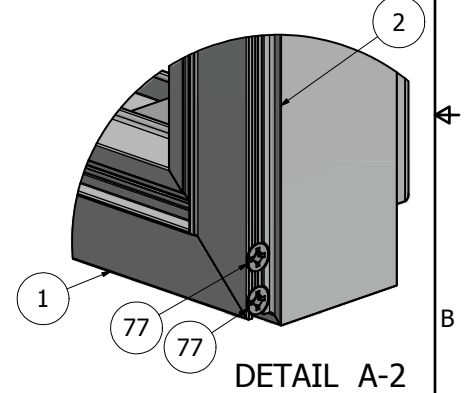
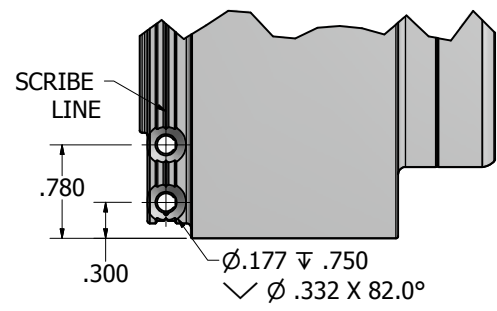
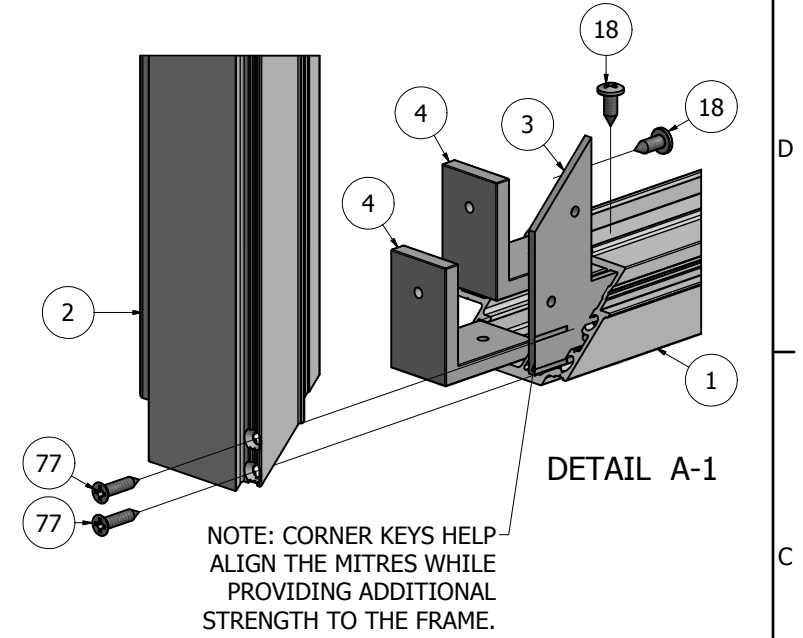
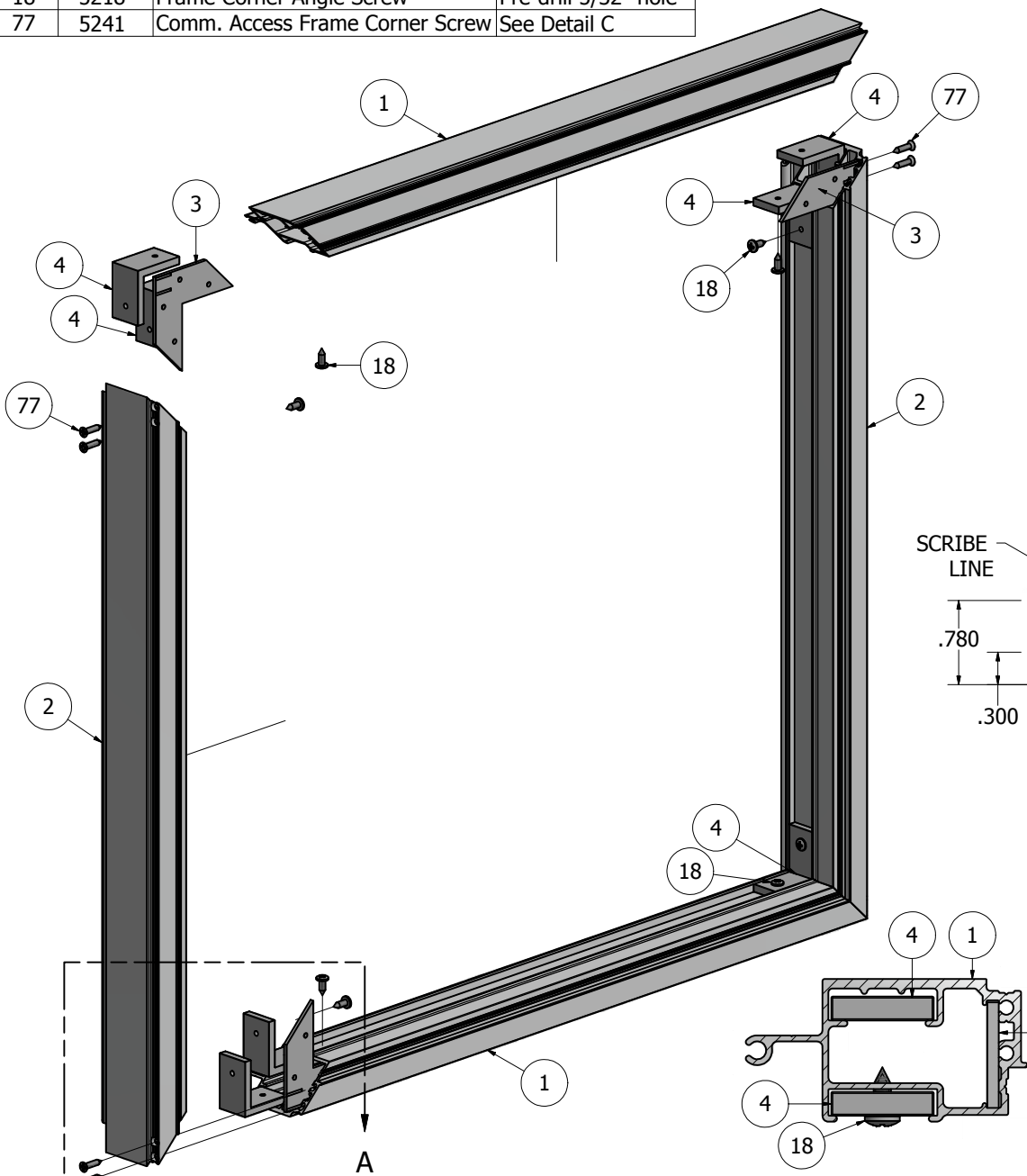

**NOTE: PRE-CUT KITS ARE NOT PRE-DRILLED.**  
(Holes shown in this drawing are for reference only.  
Drilling of pilot holes are to be done by fabricator.)

THIS DRAWING WAS CREATED AT NO CHARGE TO ASSIST YOU IN VISUALIZING OUR PROPOSAL. THE DRAWING HEREIN IS THE PROPERTY OF SIGNCOMP. PERMISSION TO COPY OR REVISE THIS DRAWING OR TO USE THIS DRAWING FOR PRODUCTION IS STRICTLY PROHIBITED AND CAN ONLY BE COPIED, REVISED OR USED FOR PRODUCTION WITH THE EXPRESSED WRITTEN PERMISSION OF SIGNCOMP.

DRAWING BY:	SBreihof	6/6/2013
Centroid X:	0.000 in	
Centroid Y:	0.000 in	
Principal Moments Ix:	0.000 in <sup>4</sup>	
Principal Moments Iy:	0.000 in <sup>4</sup>	
Section Modulus Ix:	0.000 in <sup>3</sup>	
Section Modulus Iy:	0.000 in <sup>3</sup>	

<b>SignComp</b>	
TITLE Commercial Access Frame - Assembly	
PART NO	<b>K2060</b>
REV	
SHEET 1 OF 1	

CROSS-SECTION VIEW

4 3 2 1

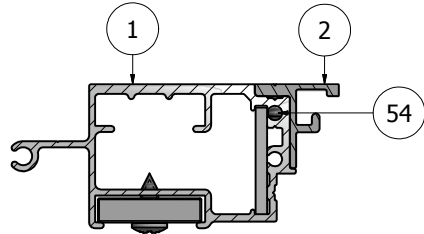

CROSS-SECTION VIEW  
TOP & BOTTOM

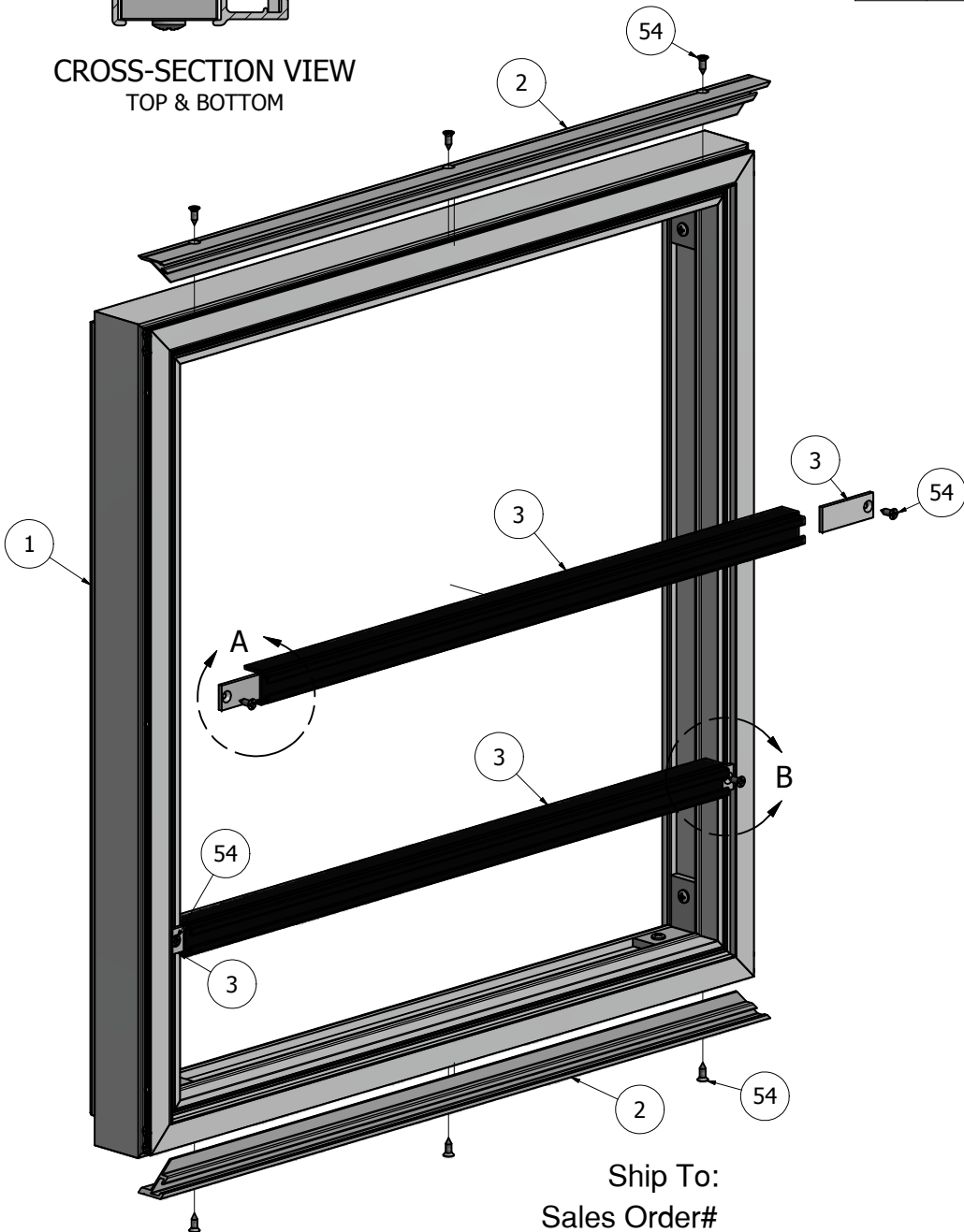

Ship To:  
Sales Order#

PARTS LIST			
ITEM	PART #	DESCRIPTION	NOTES
1	K2060	Commercial Access Frame	Assembly
2	1292	Insert Top/Bottom Cover	Attaches to the top and bottom of the Frame
3	1668	Insert Divider	
3	5306	Insert Divider Tab	Two per Divider
54	5168	Insert Divider Screw	#8 countersink -Drill 1/8" pilot hole - One per Tab

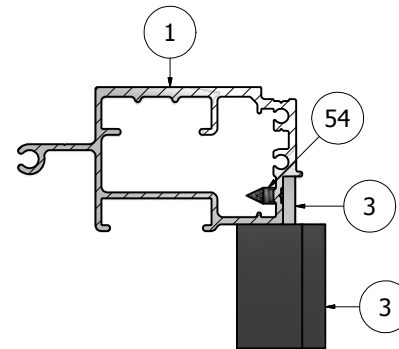

CROSS-SECTION VIEW  
SIDE

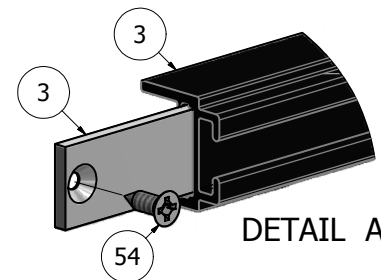

DETAIL A

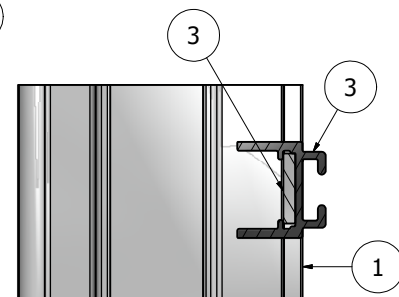

CROSS-SECTION VIEW  
THROUGH DIVIDER

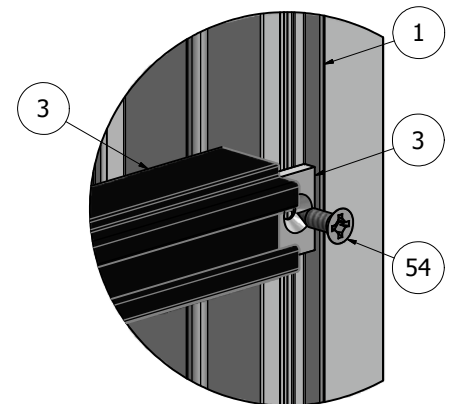

DETAIL B

**NOTE: PRE-CUT KITS ARE NOT PRE-DRILLED.**

(Holes shown in this drawing are for reference only.  
Drilling of pilot holes are to be done by fabricator.)

THIS DRAWING WAS CREATED AT NO CHARGE TO ASSIST YOU IN VISUALIZING OUR PROPOSAL. THE DRAWING HEREIN IS THE PROPERTY OF SIGNCOMP. PERMISSION TO COPY OR REVISE THIS DRAWING OR TO USE THIS DRAWING FOR PRODUCTION IS STRICTLY PROHIBITED AND CAN ONLY BE COPIED, REVISED OR USED FOR PRODUCTION WITH THE EXPRESSED WRITTEN PERMISSION OF SIGNCOMP.

DRAWING BY:	SBreihof	6/6/2013
Centroid X:	0.000 in	
Centroid Y:	0.000 in	
Principal Moments Ix:	0.000 in <sup>4</sup>	
Principal Moments Iy:	0.000 in <sup>4</sup>	
Section Modulus Ix:	0.000 in <sup>3</sup>	
Section Modulus Iy:	0.000 in <sup>3</sup>	

**SignComp**

TITLE  
Commercial Access Frame w/ Insert Covers  
and Divider - Assembly

PART NO  
**K2060-92-68**

SHEET 1 OF 1

### COVER OPTIONS

NOTE: WHEN USING THE #1698 EXT. INSERT END COVER, THE PANELS ARE CUT 1/8" SMALLER THAN THE O. D. OF THE FRAME. WHEN USING THE #1696 INSERT END COVER, THE PANELS ARE CUT 1/4" SMALLER.

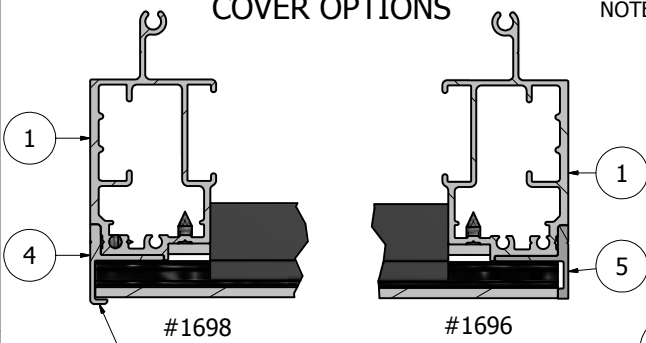

COVER WRAPS THE END OF THE PANEL. IDEAL FOR ILLUMINATED APPLICATIONS.

PARTS LIST			
ITEM	PART #	DESCRIPTION	NOTES
1	K2060/92	Commercial Access Frame / Insert Cover	Assembly
2	1292	Insert Cover	Top & Bottom
3	1668	Insert Divider	
4	1698	Extended Insert End Cover	Option for Sides
5	1696	Insert End Cover	Option for Sides
6	1689	Plastic Insert Adaptor	
7	1679	Aluminum Insert Adaptor	
8	1674/76/78	4", 6", or 8" Aluminum Insert Panel	
54	5168	Insert End Cover Screw	Drill #8 countersink

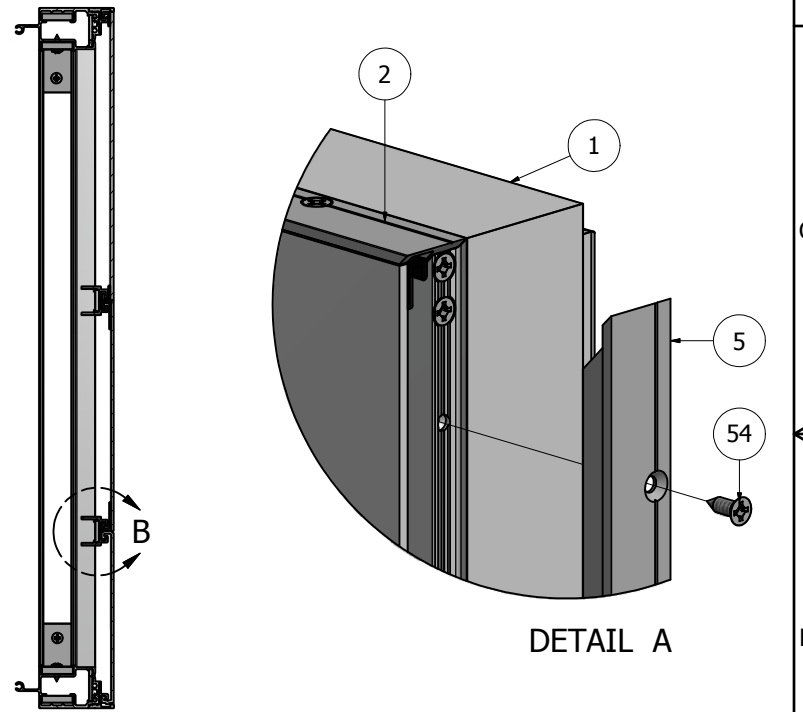
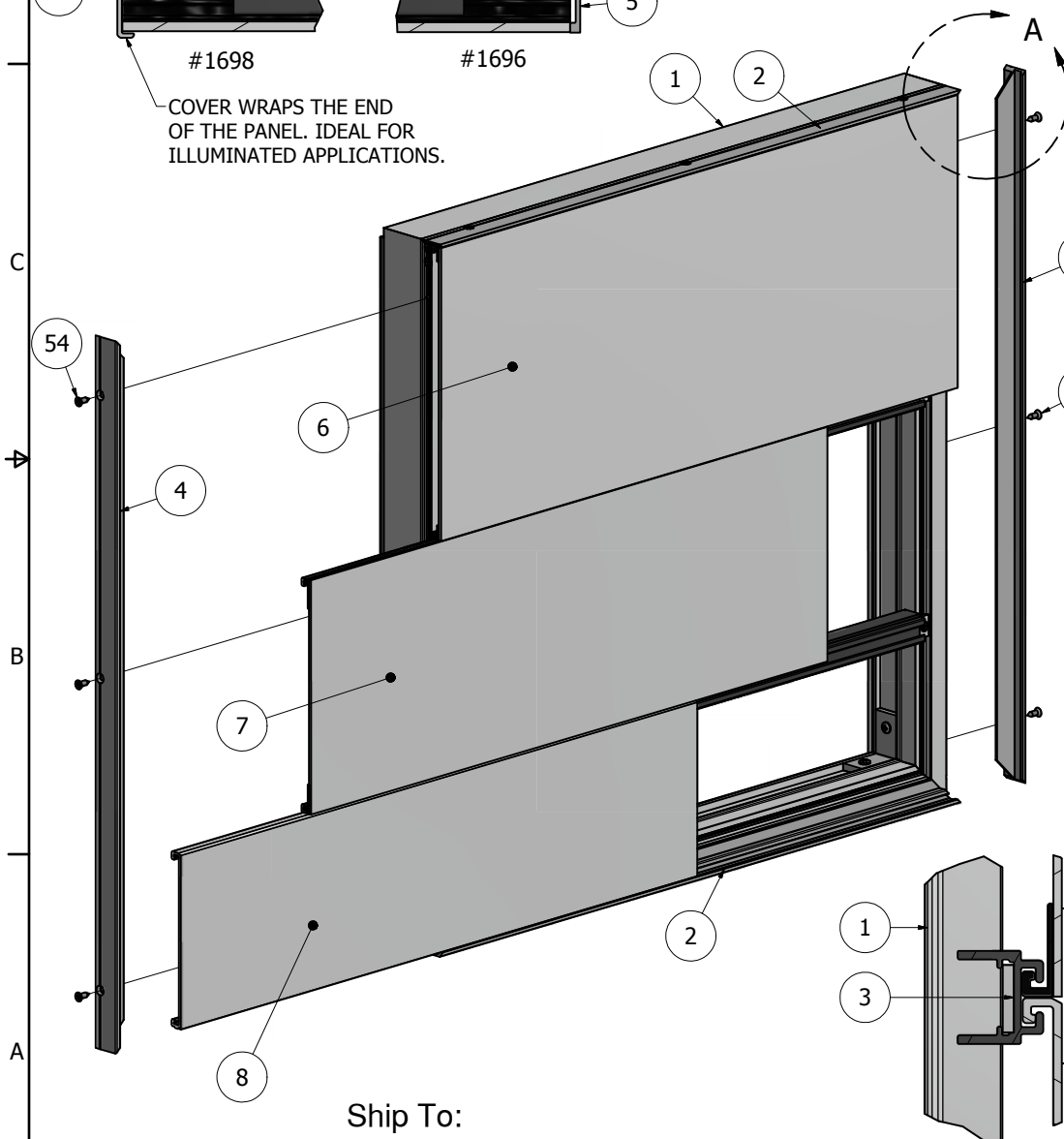

CROSS-SECTION VIEW

DETAIL A

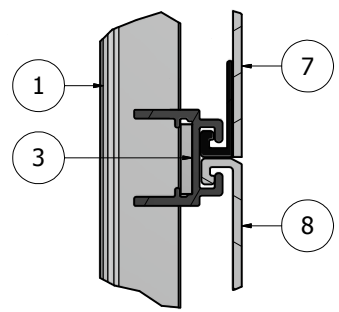

DETAIL B

**NOTE: PRE-CUT KITS ARE NOT PRE-DRILLED.**

(Holes shown in this drawing are for reference only. Drilling of pilot holes are to be done by fabricator.)

THIS DRAWING WAS CREATED AT NO CHARGE TO ASSIST YOU IN VISUALIZING OUR PROPOSAL. THE DRAWING HEREIN IS THE PROPERTY OF SIGNCOMP. PERMISSION TO COPY OR REVISE THIS DRAWING OR TO USE THIS DRAWING FOR PRODUCTION IS STRICTLY PROHIBITED AND CAN ONLY BE COPIED, REVISED OR USED FOR PRODUCTION WITH THE EXPRESSED WRITTEN PERMISSION OF SIGNCOMP.

DRAWING BY: SBreihof 6/7/2013		<b>SignComp</b>	
Centroid X: 0.000 in	Centroid Y: 0.000 in		
Principal Moments Ix: 0.000 in^4		TITLE	
Principal Moments Iy: 0.000 in^4		Commercial Access Frame w/ Panels and End Covers - Assembly	
Section Modulus Ix: 0.000 in^3		PART NO	REV
Section Modulus Iy: 0.000 in^3		<b>K2060-92-COVERS</b>	

Ship To:  
Sales Order#

PARTS LIST			
ITEM	PART #	DESCRIPTION	NOTES
1	Plastic Stock	.120 Acrylic Sheet	By Fabricator
2	Adhesive	Adhesive Tape (for Plastic) or Liquid Bonding Agent	By Fabricator
3	1689	Plastic Insert Adaptor	Attaches along the Top & Bottom on back side of panel

Ship To:  
Sales Order#

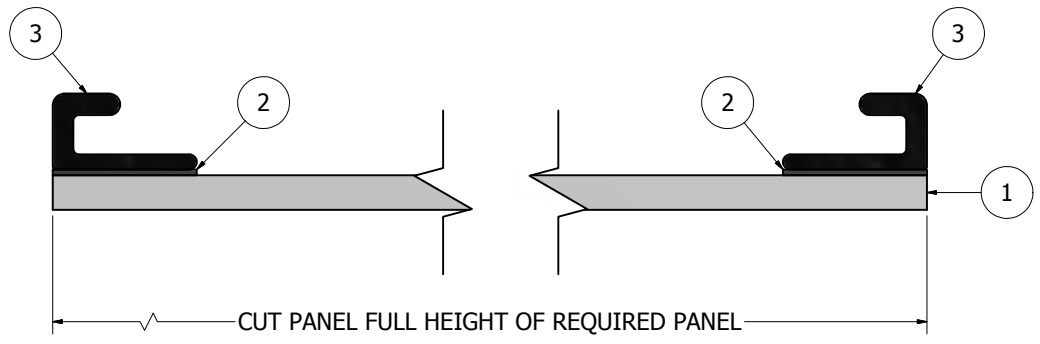
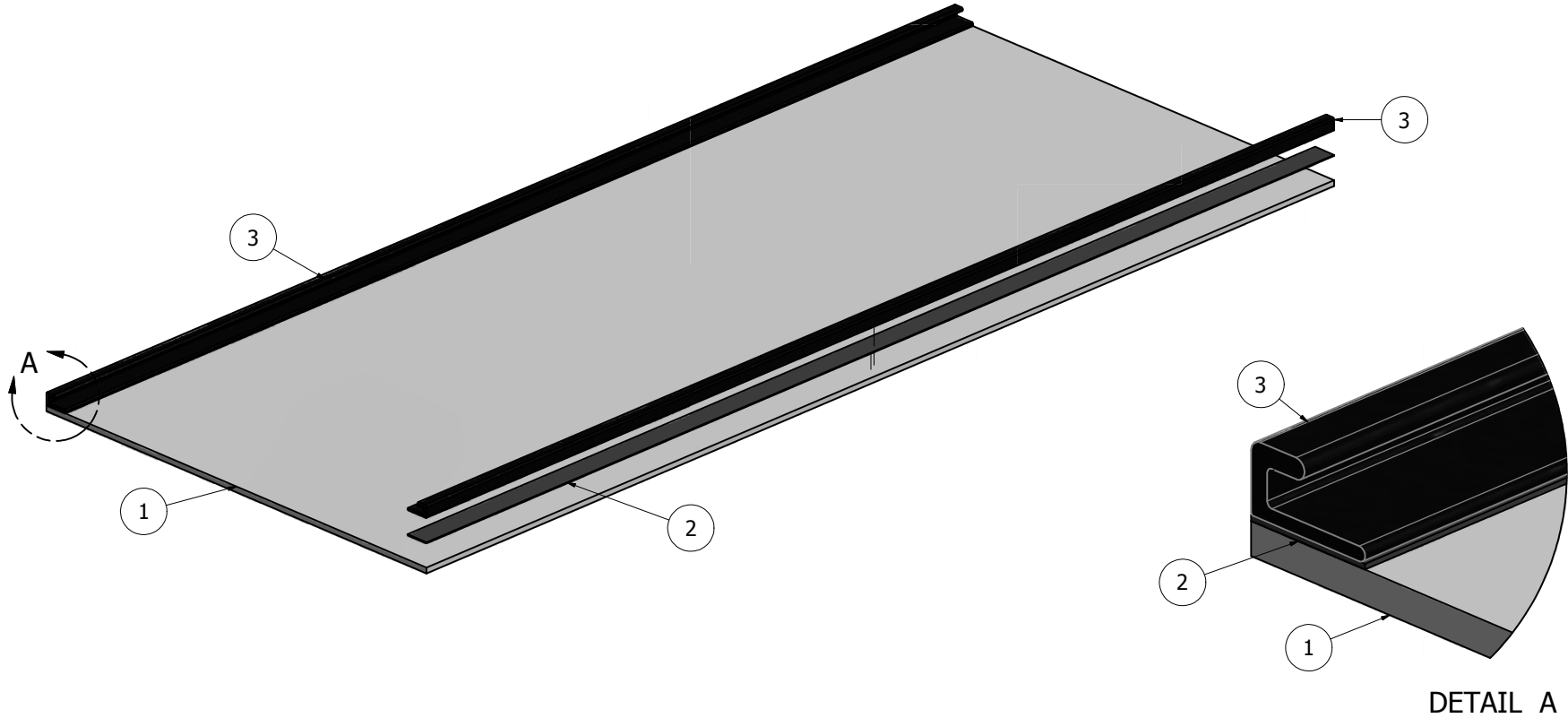

**NOTE: PRE-CUT KITS ARE NOT PRE-DRILLED.**  
(Holes shown in this drawing are for reference only.  
Drilling of pilot holes are to be done by fabricator.)

THIS DRAWING WAS CREATED AT NO CHARGE TO ASSIST YOU IN VISUALIZING OUR PROPOSAL. THE DRAWING HEREIN IS THE PROPERTY OF SIGNCOMP. PERMISSION TO COPY OR REVISE THIS DRAWING OR TO USE THIS DRAWING FOR PRODUCTION IS STRICTLY PROHIBITED AND CAN ONLY BE COPIED, REVISED OR USED FOR PRODUCTION WITH THE EXPRESSED WRITTEN PERMISSION OF SIGNCOMP.			
DRAWING BY:	SBreihof	6/7/2013	<b>SignComp</b>
Centroid X:	0.000 in	0.000 in	
Centroid Y:	0.000 in	0.000 in	TITLE
Principal Moments Ix:	0.000 in <sup>4</sup>	0.000 in <sup>4</sup>	Plastic Insert Adaptor
Principal Moments Iy:	0.000 in <sup>4</sup>	0.000 in <sup>4</sup>	
Section Modulus Ix:	0.000 in <sup>3</sup>	0.000 in <sup>3</sup>	PART NO
Section Modulus Iy:	0.000 in <sup>3</sup>	0.000 in <sup>3</sup>	<b>1689</b>
			REV
			SHEET 1 OF 1

PARTS LIST			
ITEM	PART #	DESCRIPTION	NOTES
1	Aluminum Stock	.090 Flat Aluminum Sheet	By Fabricator
2	Tape/Adhesive	Bonding Tape or Bonding Adhesive (for Aluminum)	By Fabricator
3	1679	Aluminum Insert Adaptor	Attaches along the Top & Bottom on back side of panel

Ship To:  
Sales Order#

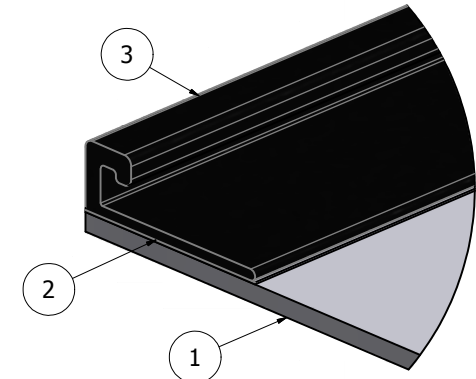
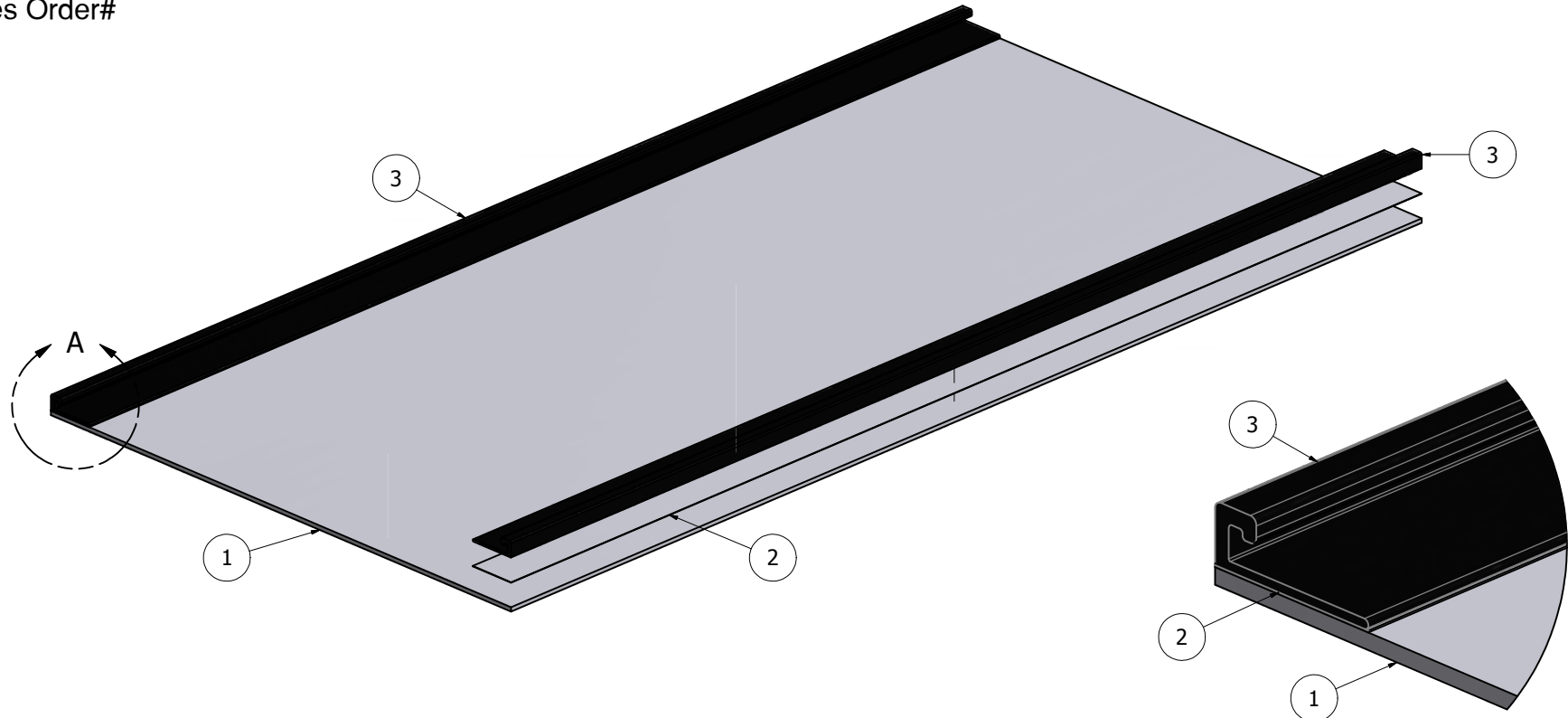

DETAIL A

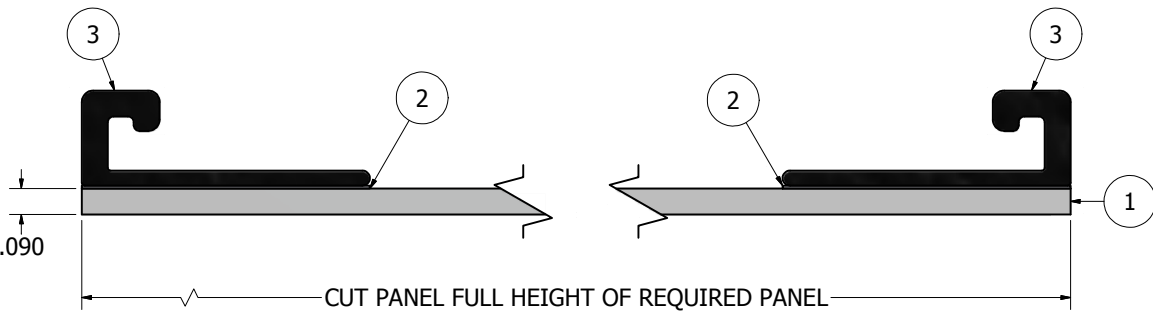

**NOTE: PRE-CUT KITS ARE NOT PRE-DRILLED.**  
(Holes shown in this drawing are for reference only.  
Drilling of pilot holes are to be done by fabricator.)

THIS DRAWING WAS CREATED AT NO CHARGE TO ASSIST YOU IN VISUALIZING OUR PROPOSAL. THE DRAWING HEREIN IS THE PROPERTY OF SIGNCOMP. PERMISSION TO COPY OR REVISE THIS DRAWING OR TO USE THIS DRAWING FOR PRODUCTION IS STRICTLY PROHIBITED AND CAN ONLY BE COPIED, REVISED OR USED FOR PRODUCTION WITH THE EXPRESSED WRITTEN PERMISSION OF SIGNCOMP.			
DRAWING BY:	SBreihof	6/7/2013	<div style="text-align: center;"> <h1>SignComp</h1> </div>
Centroid X:	0.000 in	TITLE	
Centroid Y:	0.000 in	Aluminum Insert Adaptor	
Principal Moments Ix:	0.000 in <sup>4</sup>	PART NO	REV
Principal Moments Iy:	0.000 in <sup>4</sup>	1679	
Section Modulus Ix:	0.000 in <sup>3</sup>	SHEET 1 OF 1	
Section Modulus Iy:	0.000 in <sup>3</sup>		