

| PARTS LIST |        |                                     |                                          |
|------------|--------|-------------------------------------|------------------------------------------|
| ITEM       | PART # | DESCRIPTION                         | NOTES                                    |
| 1          | K2027  | Flat Single Face Body               | Assembly                                 |
| 2          | K2204  | Flat Bleed Rigid Retainer           | Assembly                                 |
| 79         | 5175   | Hinge Screw - #10 x 5/8" Pan Head   | Pre-drill 5/32" pilot hole every 36" o/c |
| 80         | 5175   | Closure Screw - #10 x 5/8" Pan Head | Pre-drill 5/32" pilot hole every 48" o/c |

Ship To:  
Sales Order#

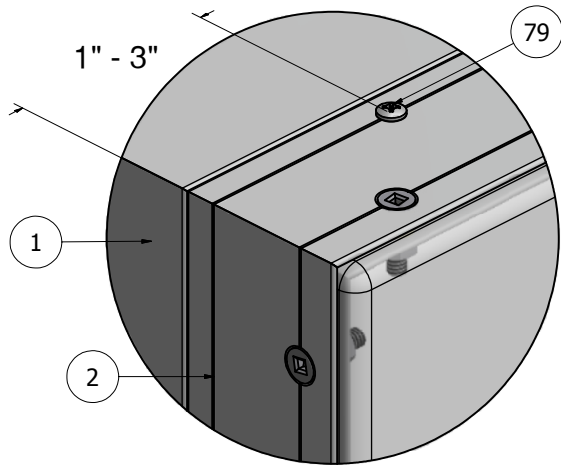

DETAIL A  
FRAME CLOSED

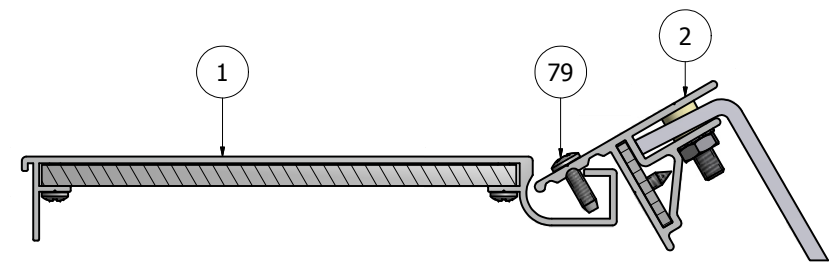
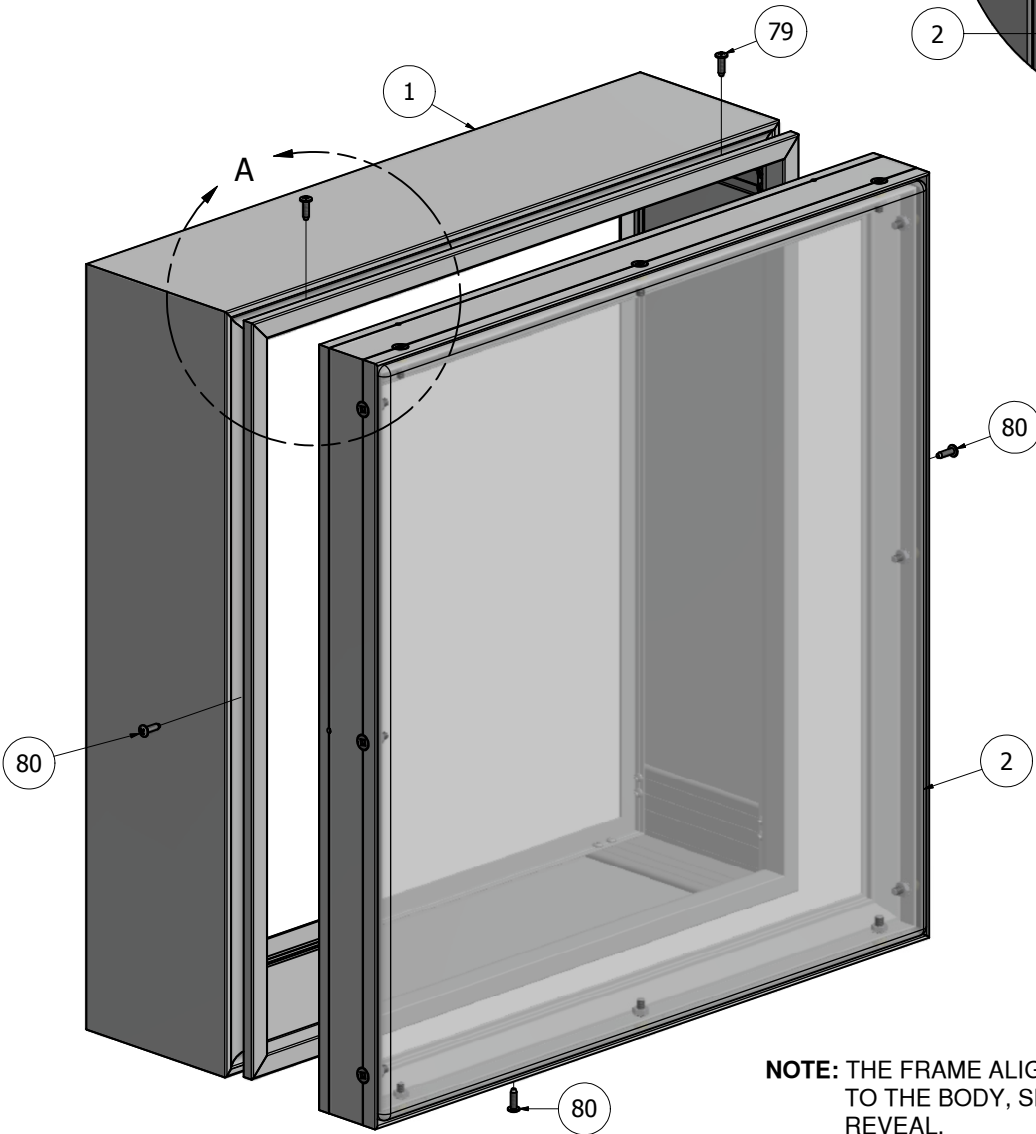
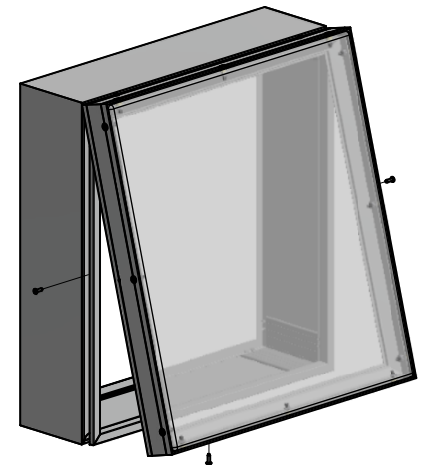

TOP CROSS-SECTION VIEW

**NOTE: PRE-CUT KITS ARE NOT PRE-DRILLED.**  
(Holes shown in this drawing are for reference only.  
Drilling of pilot holes are to be done by fabricator.)

THIS DRAWING WAS CREATED AT NO CHARGE TO ASSIST YOU IN VISUALIZING OUR PROPOSAL. THE DRAWING HEREIN IS THE PROPERTY OF SIGNCOMP. PERMISSION TO COPY OR REVISE THIS DRAWING OR TO USE THIS DRAWING FOR PRODUCTION IS STRICTLY PROHIBITED AND CAN ONLY BE COPIED, REVISED OR USED FOR PRODUCTION WITH THE EXPRESSED WRITTEN PERMISSION OF SIGNCOMP.

|                       |                       |           |
|-----------------------|-----------------------|-----------|
| DRAWING BY:           | SBreihof              | 9/11/2013 |
| Centroid X:           | 0.000 in              |           |
| Centroid Y:           | 0.000 in              |           |
| Principal Moments Ix: | 0.000 in <sup>4</sup> |           |
| Principal Moments Iy: | 0.000 in <sup>4</sup> |           |
| Section Modulus Ix:   | 0.000 in <sup>3</sup> |           |
| Section Modulus Iy:   | 0.000 in <sup>3</sup> |           |

|                 |                   |                                                               |
|-----------------|-------------------|---------------------------------------------------------------|
| <b>SignComp</b> |                   | TITLE                                                         |
|                 |                   | Flat Single Face Body w/ Flat Bleed Rigid Retainer - Assembly |
| PART NO         | <b>K2027-2204</b> | REV                                                           |
|                 |                   | SHEET 1 OF 1                                                  |

**NOTE: THE FRAME ALIGNS TIGHT TO THE BODY, SHOWING NO REVEAL.**

| PARTS LIST |        |                                     |                           |
|------------|--------|-------------------------------------|---------------------------|
| ITEM       | PART # | DESCRIPTION                         | NOTES                     |
| 1          | 2027   | Flat Single Face Body               | Top & Bottom              |
| 2          | 2027   | Flat Single Face Body               | Sides                     |
| 3          | 5327   | Flat Single Face Body Corner Angle  | One (1) per corner        |
| 81         | 5199   | Flat Single Face Corner Angle Screw | Pre-drill 1/8" pilot hole |

Ship To:  
Sales Order#

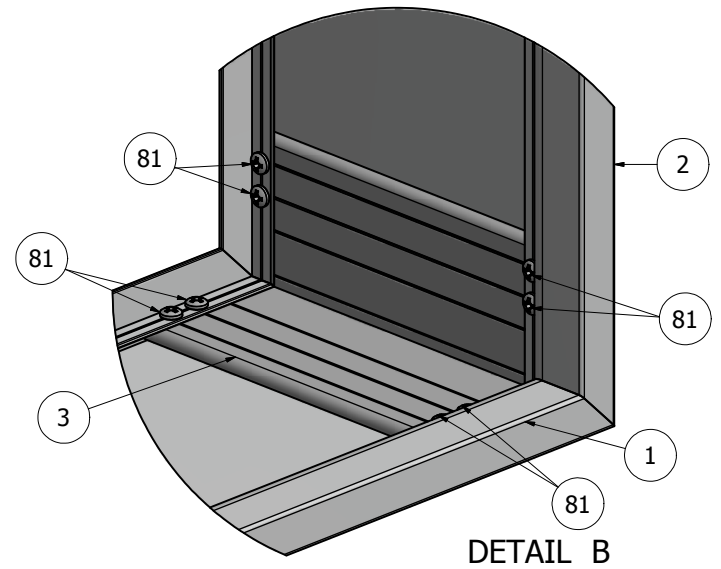
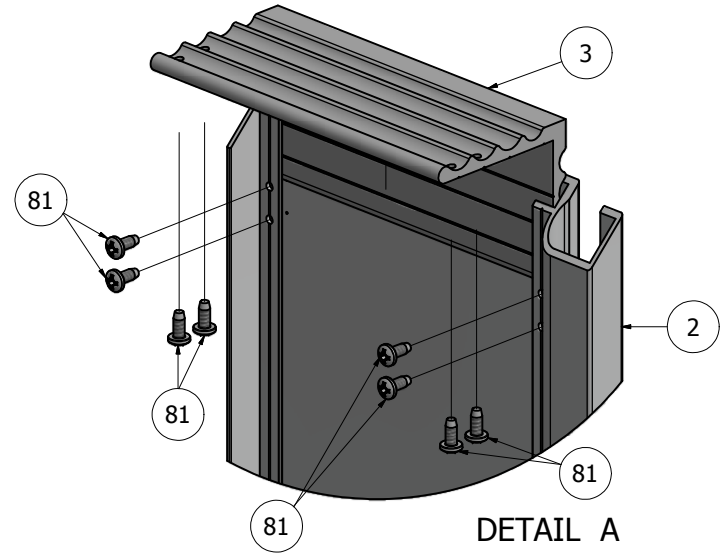
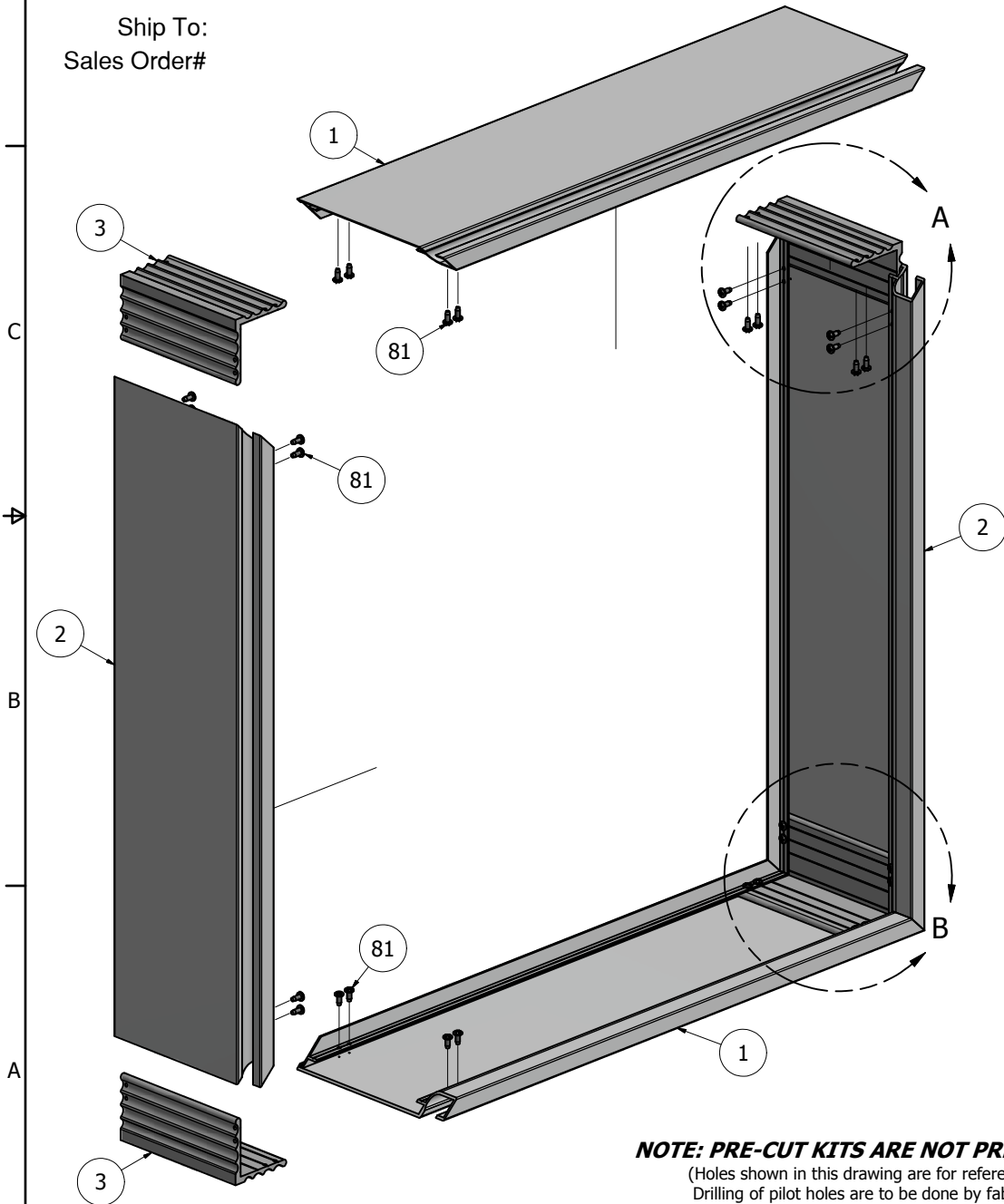

**NOTE: PRE-CUT KITS ARE NOT PRE-DRILLED.**  
(Holes shown in this drawing are for reference only.  
Drilling of pilot holes are to be done by fabricator.)

THIS DRAWING WAS CREATED AT NO CHARGE TO ASSIST YOU IN VISUALIZING OUR PROPOSAL. THE DRAWING HEREIN IS THE PROPERTY OF SIGNCOMP. PERMISSION TO COPY OR REVISE THIS DRAWING OR TO USE THIS DRAWING FOR PRODUCTION IS STRICTLY PROHIBITED AND CAN ONLY BE COPIED, REVISED OR USED FOR PRODUCTION WITH THE EXPRESSED WRITTEN PERMISSION OF SIGNCOMP.

|                       |                       |           |
|-----------------------|-----------------------|-----------|
| DRAWING BY:           | SBreihof              | 8/14/2013 |
| Centroid X:           | 0.000 in              |           |
| Centroid Y:           | 0.000 in              |           |
| Principal Moments Ix: | 0.000 in <sup>4</sup> |           |
| Principal Moments Iy: | 0.000 in <sup>4</sup> |           |
| Section Modulus Ix:   | 0.000 in <sup>3</sup> |           |
| Section Modulus Iy:   | 0.000 in <sup>3</sup> |           |

|                   |       |       |                                  |
|-------------------|-------|-------|----------------------------------|
| <h1>SignComp</h1> |       |       |                                  |
|                   |       | TITLE | Flat Single Face Body - Assembly |
| PART NO           | K2027 | REV   |                                  |
| SHEET 1 OF 1      |       |       |                                  |

|      |       | PARTS LIST                |                                                          |
|------|-------|---------------------------|----------------------------------------------------------|
| ITEM | PART# | DESCRIPTION               | NOTES                                                    |
| 1    | 2204  | Flat Bleed Retro Frame    | Top & Bottom                                             |
| 2    | 2204  | Flat Bleed Retro Frame    | Sides                                                    |
| 3    | 5210  | Corner Key                |                                                          |
| 82   | 5168  | Flat Bleed Retainer Screw | #8 x 1/2" Countersink - Predrill & Countersink 1/8" hole |

Ship To:  
Sales Order#

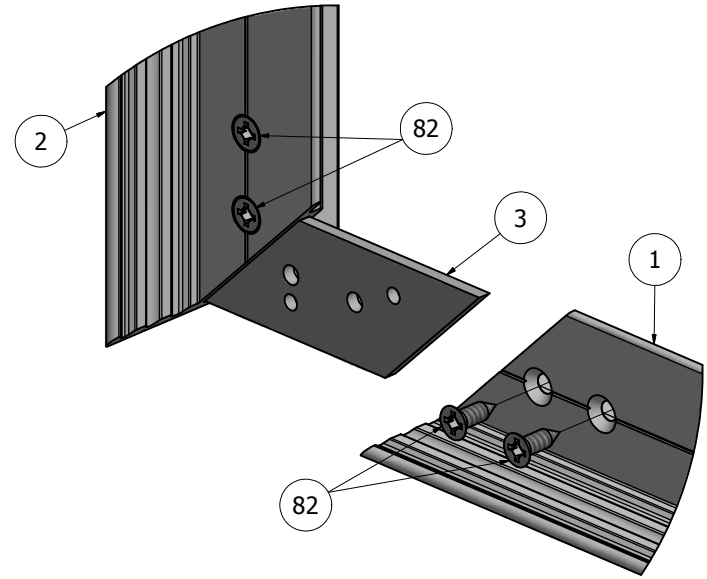
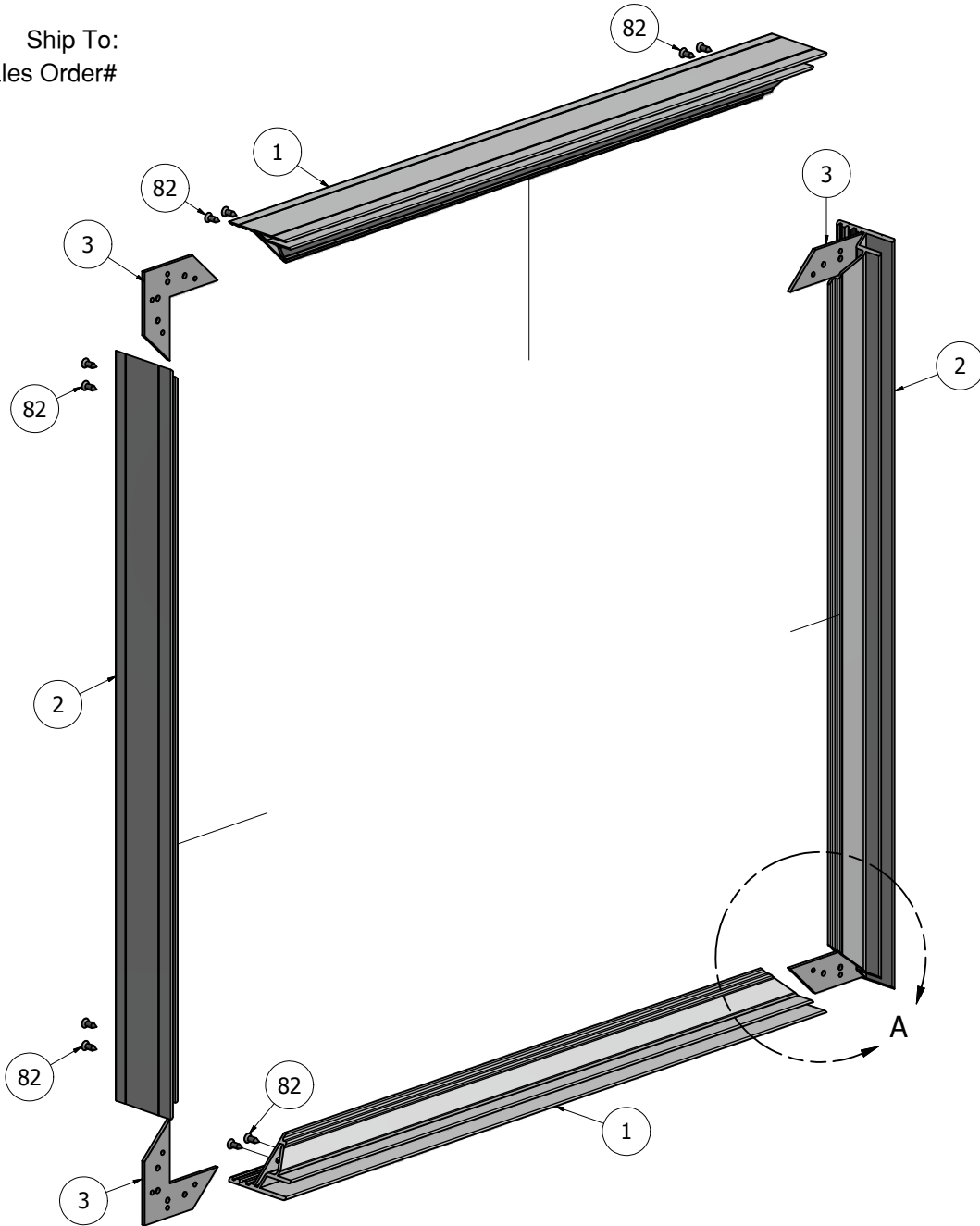

DETAIL A  
BACK SIDE

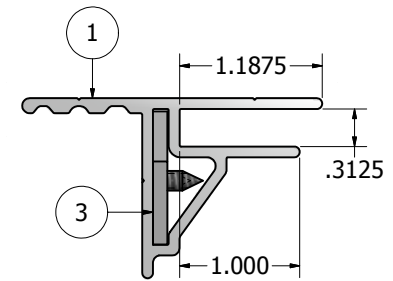

CROSS-SECTION VIEW

**NOTE: PRE-CUT KITS ARE NOT PRE-DRILLED.**  
(Holes shown in this drawing are for reference only.  
Drilling of pilot holes are to be done by fabricator.)

THIS DRAWING WAS CREATED AT NO CHARGE TO ASSIST YOU IN VISUALIZING OUR PROPOSAL. THE DRAWING HEREIN IS THE PROPERTY OF SIGNCOMP. PERMISSION TO COPY OR REVISE THIS DRAWING OR TO USE THIS DRAWING FOR PRODUCTION IS STRICTLY PROHIBITED AND CAN ONLY BE COPIED, REVISED OR USED FOR PRODUCTION WITH THE EXPRESSED WRITTEN PERMISSION OF SIGNCOMP.

|                       |                       |           |                           |
|-----------------------|-----------------------|-----------|---------------------------|
| DRAWING BY:           | SBreihof              | 8/27/2013 | <b>SignComp</b>           |
| Centroid X:           | 0.000 in              |           |                           |
| Centroid Y:           | 0.000 in              |           | TITLE                     |
| Principal Moments Ix: | 0.000 in <sup>4</sup> |           | Flat Bleed Rigid Retainer |
| Principal Moments Iy: | 0.000 in <sup>4</sup> |           | PART NO                   |
| Section Modulus Ix:   | 0.000 in <sup>3</sup> |           | <b>K2204</b>              |
| Section Modulus Iy:   | 0.000 in <sup>3</sup> |           | REV                       |

| PARTS LIST |       |                                                                                   |                            |
|------------|-------|-----------------------------------------------------------------------------------|----------------------------|
| ITEM       | PART# | DESCRIPTION                                                                       | NOTES                      |
| 1          | K2204 | Flat Bleed Rigid Retainer                                                         | Assembly                   |
| 1.3        | 5210  | Corner Key                                                                        |                            |
| 1.4        | 5168  | Flat Bleed Rigid Retainer Screw                                                   |                            |
| 2          |       | 3/16" Polycarbonate Pan Face                                                      | By Other                   |
| 3          | 5285  | Rigid Face Hardware                                                               | Assembly - Approx. 18" o/c |
| 3.1        |       | 1/4" x 20 Lock Nut                                                                |                            |
| 3.2        |       | Nylon Bushing                                                                     |                            |
| 3.3        |       | 1/4" x 20 x 1" UNC Square Recessed Flat Countersunk Head Machine Screw - Type III |                            |

Ship To:  
Sales Order#

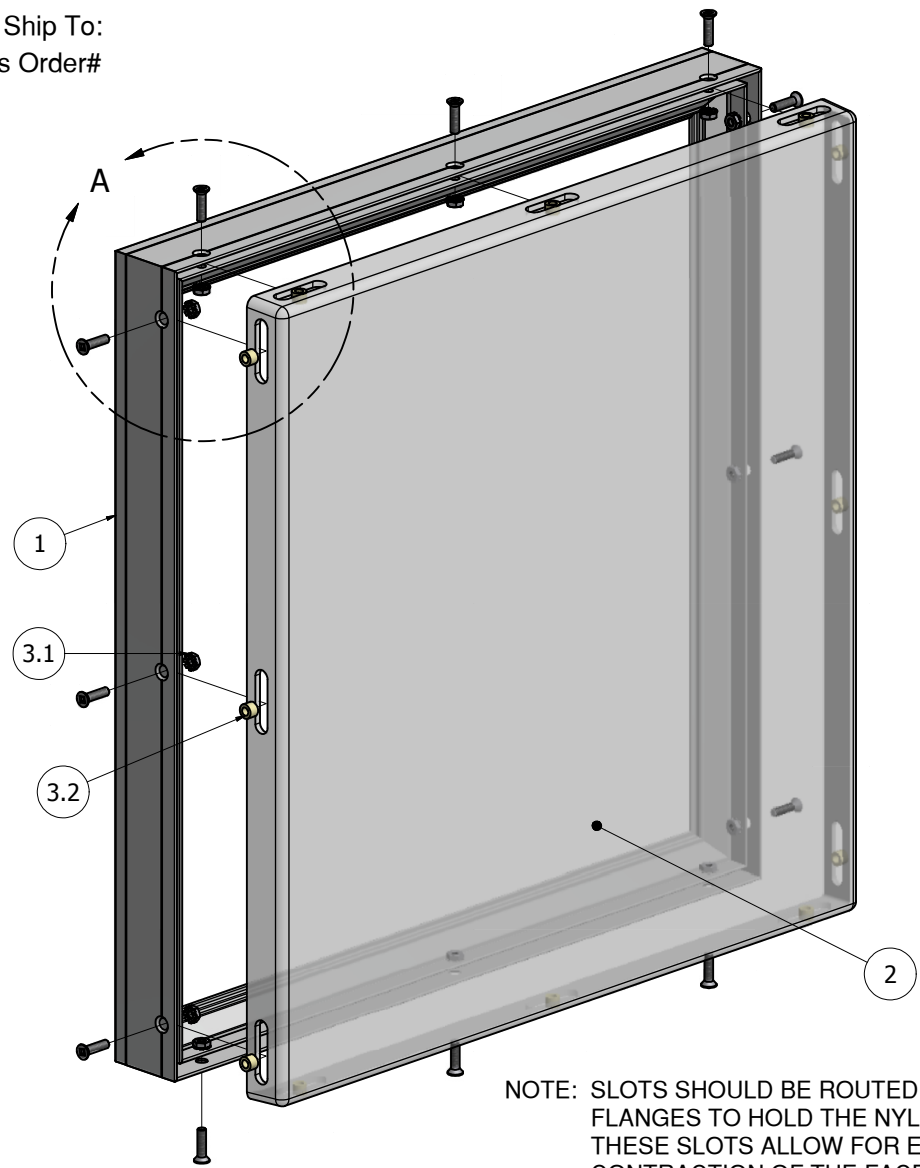

NOTE: SLOTS SHOULD BE ROUTED INTO THE FACE FLANGES TO HOLD THE NYLON BUSHINGS. THESE SLOTS ALLOW FOR EXPANSION AND CONTRACTION OF THE FACE MATERIAL.

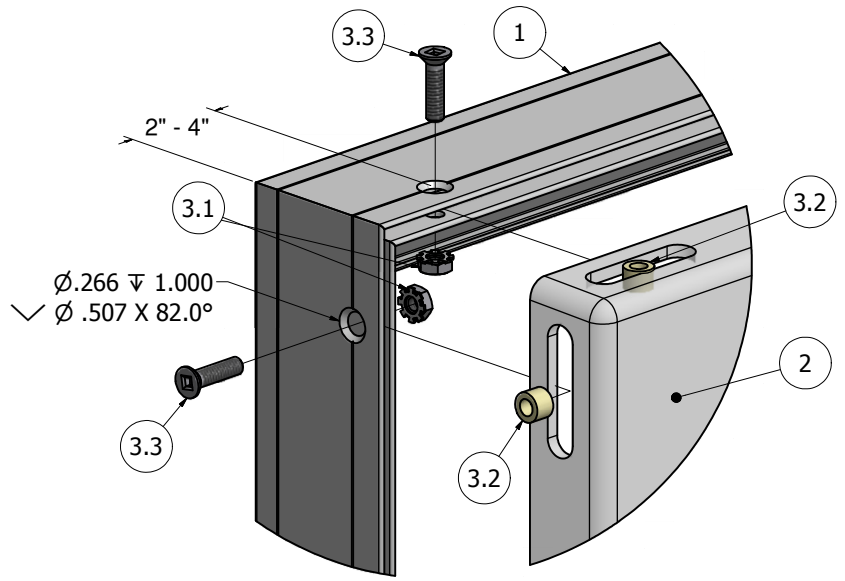

DETAIL A-1

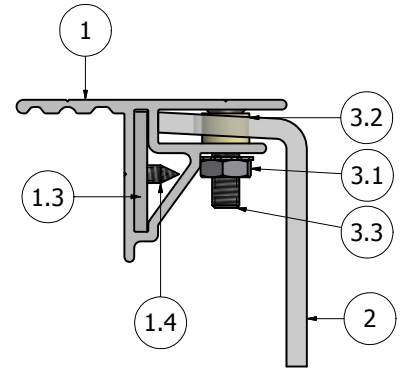

CROSS-SECTION VIEW

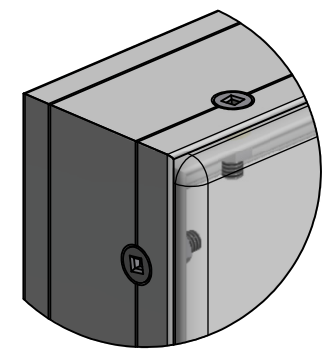

DETAIL A-2  
ASSEMBLED

**NOTE: PRE-CUT KITS ARE NOT PRE-DRILLED.**  
(Holes shown in this drawing are for reference only. Drilling of pilot holes are to be done by fabricator.)

|                                             |                      |                                           |
|---------------------------------------------|----------------------|-------------------------------------------|
| DRAWING BY: SBreihof 8/27/2013              |                      | <b>SignComp</b>                           |
| Centroid X: 0.000 in                        | Centroid Y: 0.000 in |                                           |
| Principal Moments Ix: 0.000 in <sup>4</sup> |                      | Flat Bleed Rigid Retainer Face - Assembly |
| Principal Moments Iy: 0.000 in <sup>4</sup> |                      |                                           |
| Section Modulus Ix: 0.000 in <sup>3</sup>   |                      | PART NO <b>K2204-FACE</b> REV             |
| Section Modulus Iy: 0.000 in <sup>3</sup>   |                      |                                           |
| SHEET 1 OF 1                                |                      |                                           |