

Parts List			
ITEM	PART#	DESCRIPTION	NOTES
1	K2015	Medium Body	Assembly
2	K2045-65	2-1/4" Retainer w/ Dual Frame	Assembly
10	5170	Hinge Screw	Drill 3/8" pilot hole
11	5180	Closure Screw	Drill 5/16" pilot hole

Ship To:  
Order Number:

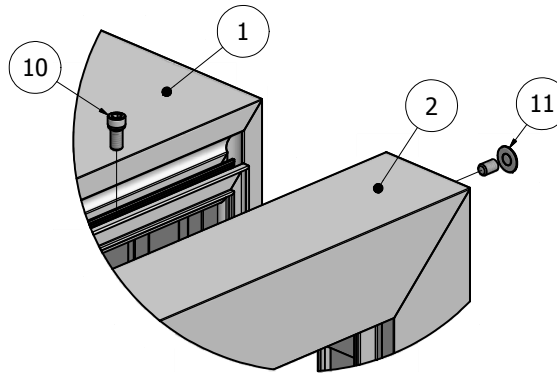

DETAIL A

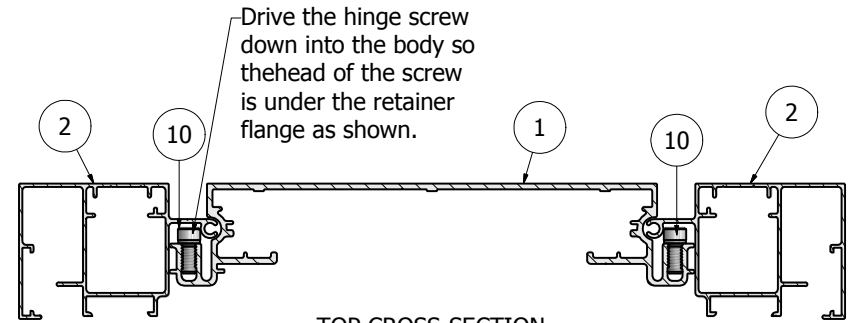
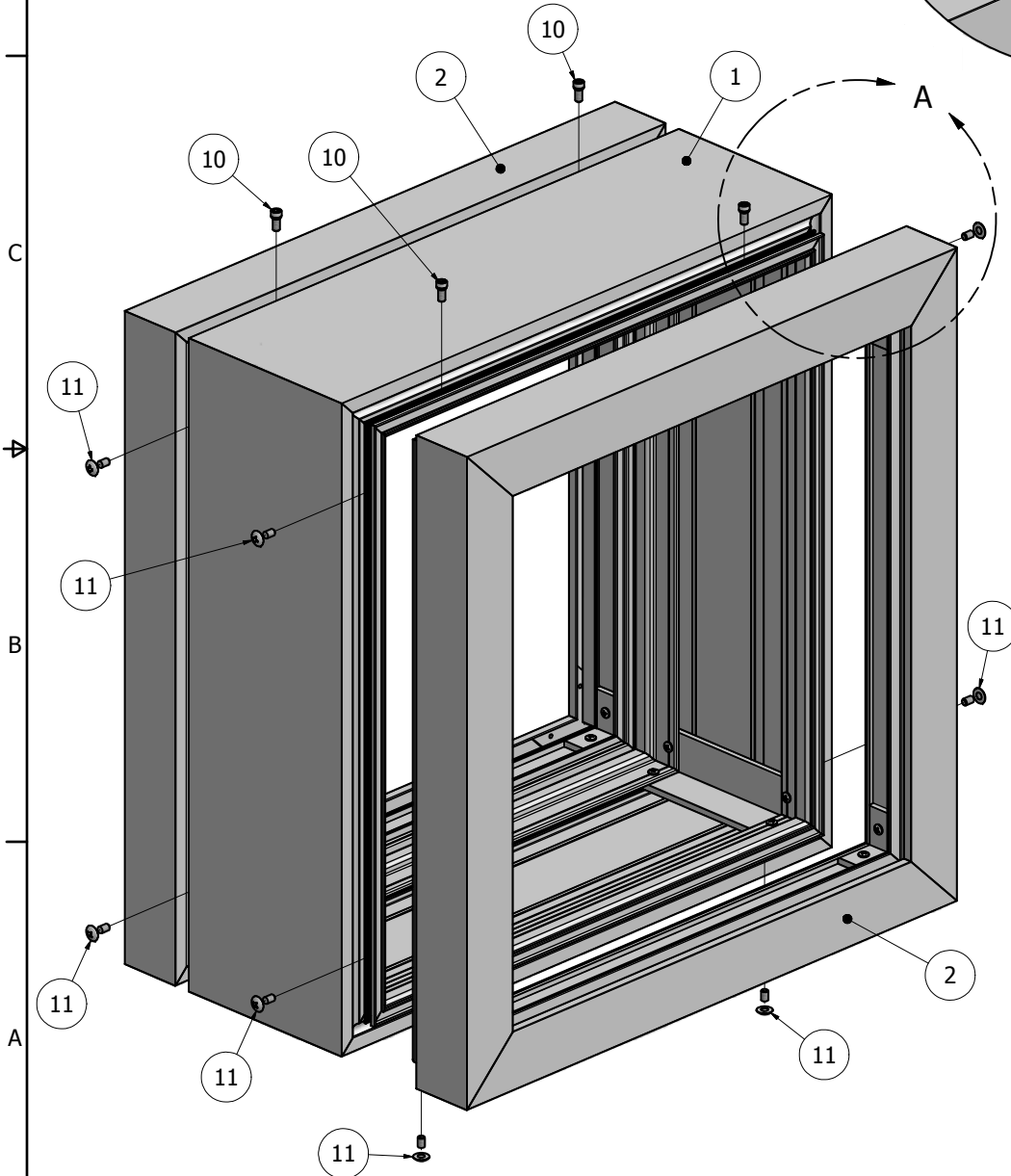
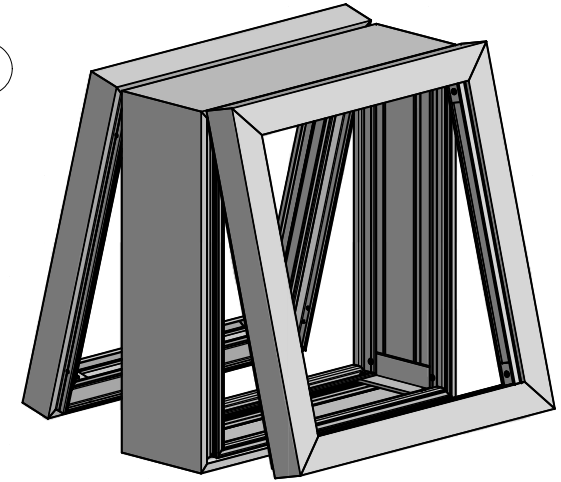

TOP CROSS-SECTION

**NOTE: PRE-CUT KITS ARE NOT PRE-DRILLED.**

(Holes shown in this drawing are for reference only. Drilling of pilot holes are to be done by fabricator.)

THIS DRAWING WAS CREATED AT NO CHARGE TO ASSIST YOU IN VISUALIZING OUR PROPOSAL. THE DRAWING HEREIN IS THE PROPERTY OF SIGNCOMP. PERMISSION TO COPY OR REVISE THIS DRAWING OR TO USE THIS DRAWING FOR PRODUCTION IS STRICTLY PROHIBITED AND CAN ONLY BE COPIED, REVISED OR USED FOR PRODUCTION WITH THE EXPRESSED WRITTEN PERMISSION OF SIGNCOMP.

DRAWN	Sarah	3/22/2012	<b>SignComp</b>
Centroid X:	0.000 in		
Centroid Y:	0.000 in		TITLE
Principal Moments Ix:	0.000 in <sup>4</sup>		Medium Body w/ 2-1/4" Retainer - Assembly
Principal Moments Iy:	0.000 in <sup>4</sup>		DWG NO
Section Modulus Ix:	0.000 in <sup>3</sup>		<b>KMB-45 with 2065</b>
Section Modulus Iy:	0.000 in <sup>3</sup>		REV

Parts List			
ITEM	PART #	DESCRIPTION	NOTES
1	2015	Medium Body	Top & Bottom
2	2015	Medium Body	Sides
3	5318	Medium Body Corner Angle	
13	5218	Corner Angle Screw	Drill 5/32" pilot hole

D

C

B

A

A

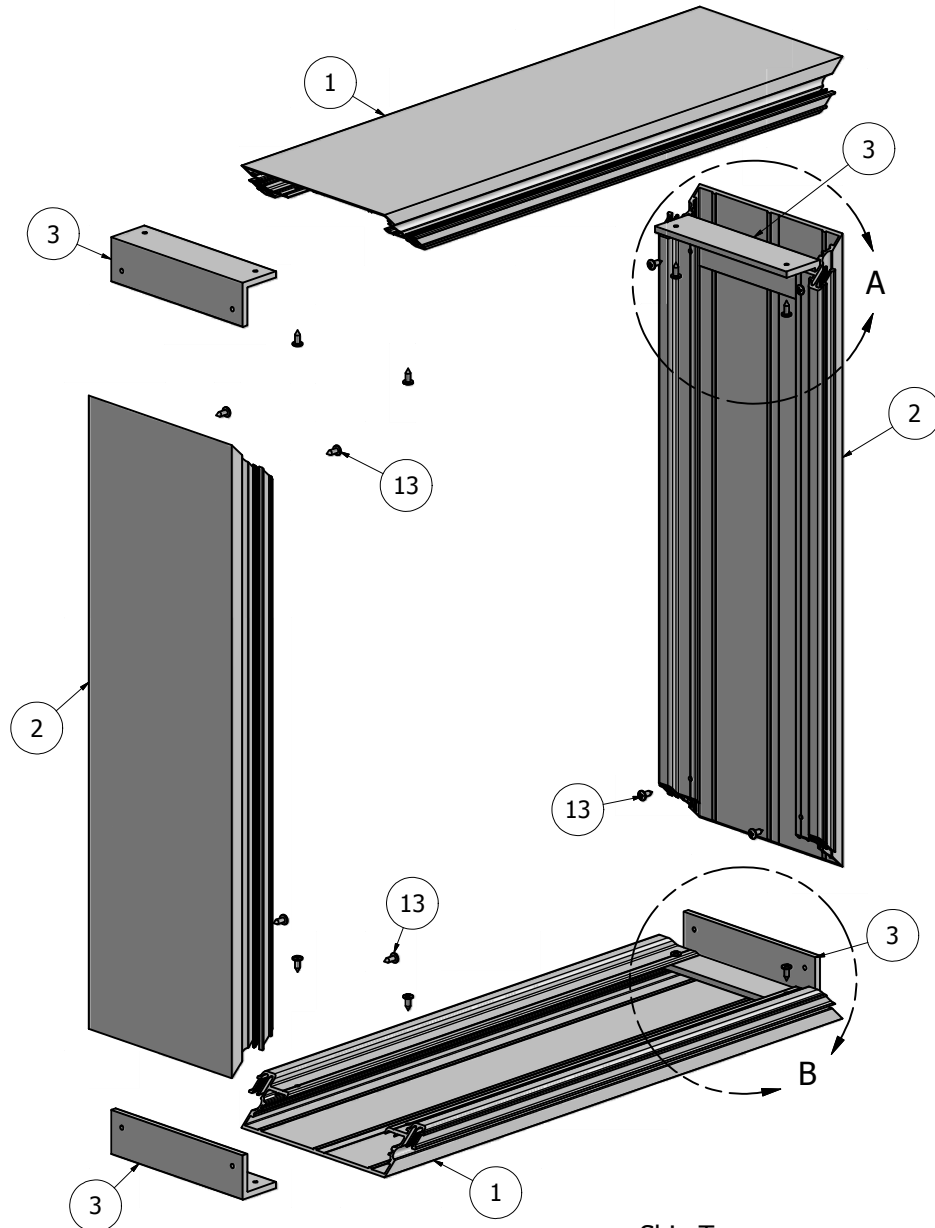

Ship To:  
Order Number:

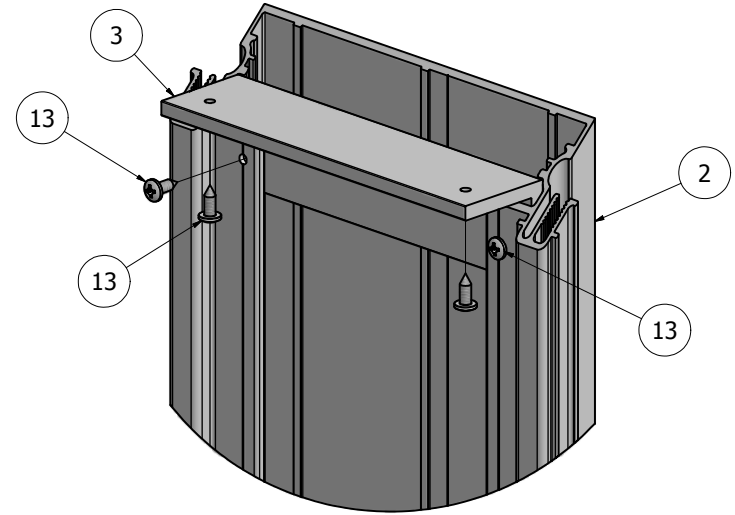

DETAIL A

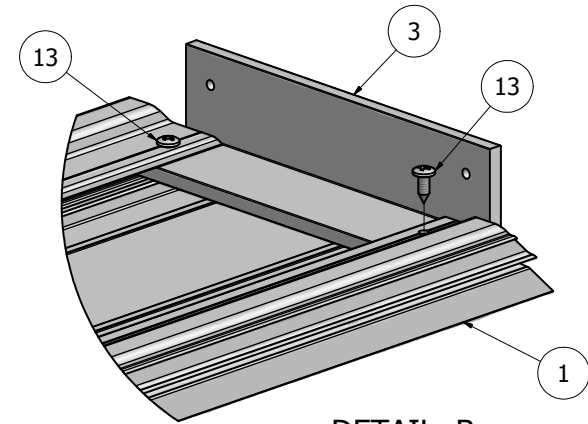

DETAIL B

**NOTE: PRE-CUT KITS ARE NOT PRE-DRILLED.**

(Holes shown in this drawing are for reference only.  
Drilling of pilot holes are to be done by fabricator.)

THIS DRAWING WAS CREATED AT NO CHARGE TO ASSIST YOU IN VISUALIZING OUR PROPOSAL. THE DRAWING HEREIN IS THE PROPERTY OF SIGNCOMP. PERMISSION TO COPY OR REVISE THIS DRAWING OR TO USE THIS DRAWING FOR PRODUCTION IS STRICTLY PROHIBITED AND CAN ONLY BE COPIED, REVISED OR USED FOR PRODUCTION WITH THE EXPRESSED WRITTEN PERMISSION OF SIGNCOMP.

DRAWN	Sarah	3/5/2012	<b>SignComp</b>	
Centroid X:	0.000 in	TITLE		
Centroid Y:	0.000 in	Medium Body - Assembly		
Principal Moments Ix:	0.000 in <sup>4</sup>	DWG NO	<b>K2015</b>	REV
Principal Moments Iy:	0.000 in <sup>4</sup>			
Section Modulus Ix:	0.000 in <sup>3</sup>			
Section Modulus Iy:	0.000 in <sup>3</sup>			

SHEET 1 OF 1

Parts List			
ITEM	PART #	DESCRIPTION	NOTES
1	2045	2-1/4" Retainer	Top & Bottom
2	2045	2-1/4" Retainer	Side
3	5210	Corner Key	
4	5305	Frame Corner Angle	
5	2065	Dual Frame	Side
6	2075	Dual Frame Cover	Side
12	5195	Cover Screw	Pre-drill 3/32" pilot hole
13	5218	Corner Angle Screw	Drill 5/32" pilot hole

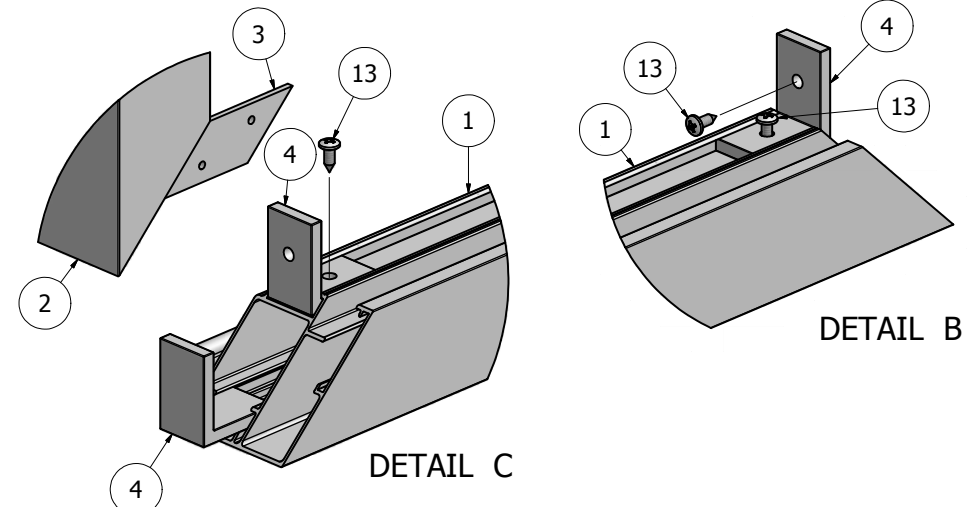
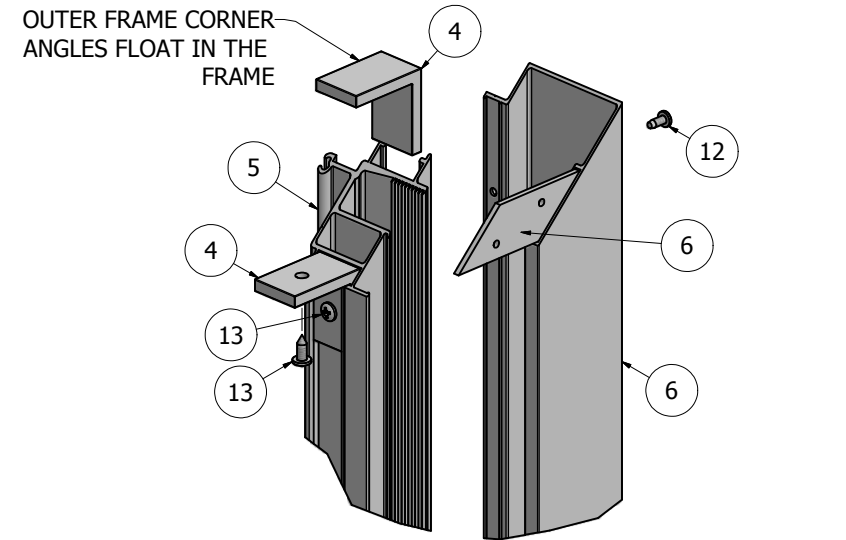
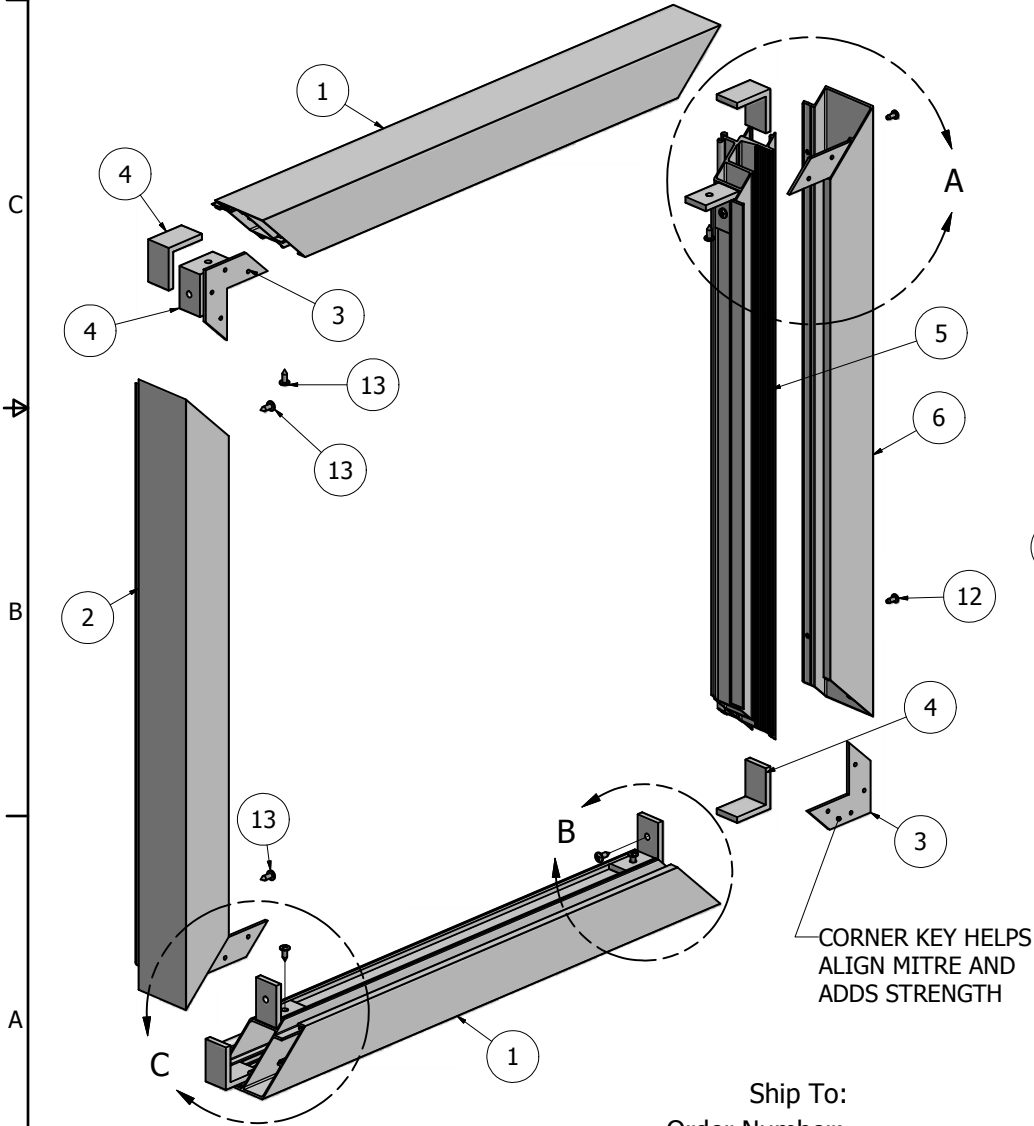

**NOTE: PRE-CUT KITS ARE NOT PRE-DRILLED.**  
 (Holes shown in this drawing are for reference only. Drilling of pilot holes are to be done by fabricator.)

THIS DRAWING WAS CREATED AT NO CHARGE TO ASSIST YOU IN VISUALIZING OUR PROPOSAL. THE DRAWING HEREIN IS THE PROPERTY OF SIGNCOMP. PERMISSION TO COPY OR REVISE THIS DRAWING OR TO USE THIS DRAWING FOR PRODUCTION IS STRICTLY PROHIBITED AND CAN ONLY BE COPIED, REVISED OR USED FOR PRODUCTION WITH THE EXPRESSED WRITTEN PERMISSION OF SIGNCOMP.		
DRAWN	Sarah	3/5/2012
Centroid X:	0.000 in	
Centroid Y:	0.000 in	
Principal Moments Ix:	0.000 in <sup>4</sup>	
Principal Moments Iy:	0.000 in <sup>4</sup>	
Section Modulus Ix:	0.000 in <sup>3</sup>	
Section Modulus Iy:	0.000 in <sup>3</sup>	
<h1 style="text-align: center;">SignComp</h1>		TITLE
		2-1/4" Retainer w/ Dual Frame and Cover - Assembly
DWG NO		REV
<b>K2045-65</b>		
SHEET 1 OF 1		

Ship To:  
Order Number: