

Parts List			
ITEM	PART#	DESCRIPTION	NOTES
1	K2025	Single Face Body	Assembly
2	K2099-42	Small Inner / Outer Frame Retainer	Assembly
10	5170	Hinge Screw	Drill 3/8" pilot hole
11	5180	Closure Screw	Drill 5/16" pilot hole

Ship To:  
Order Number:

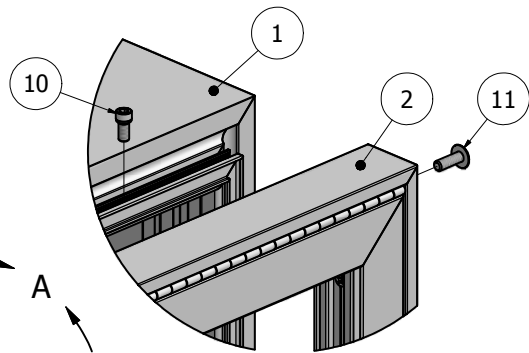

DETAIL A

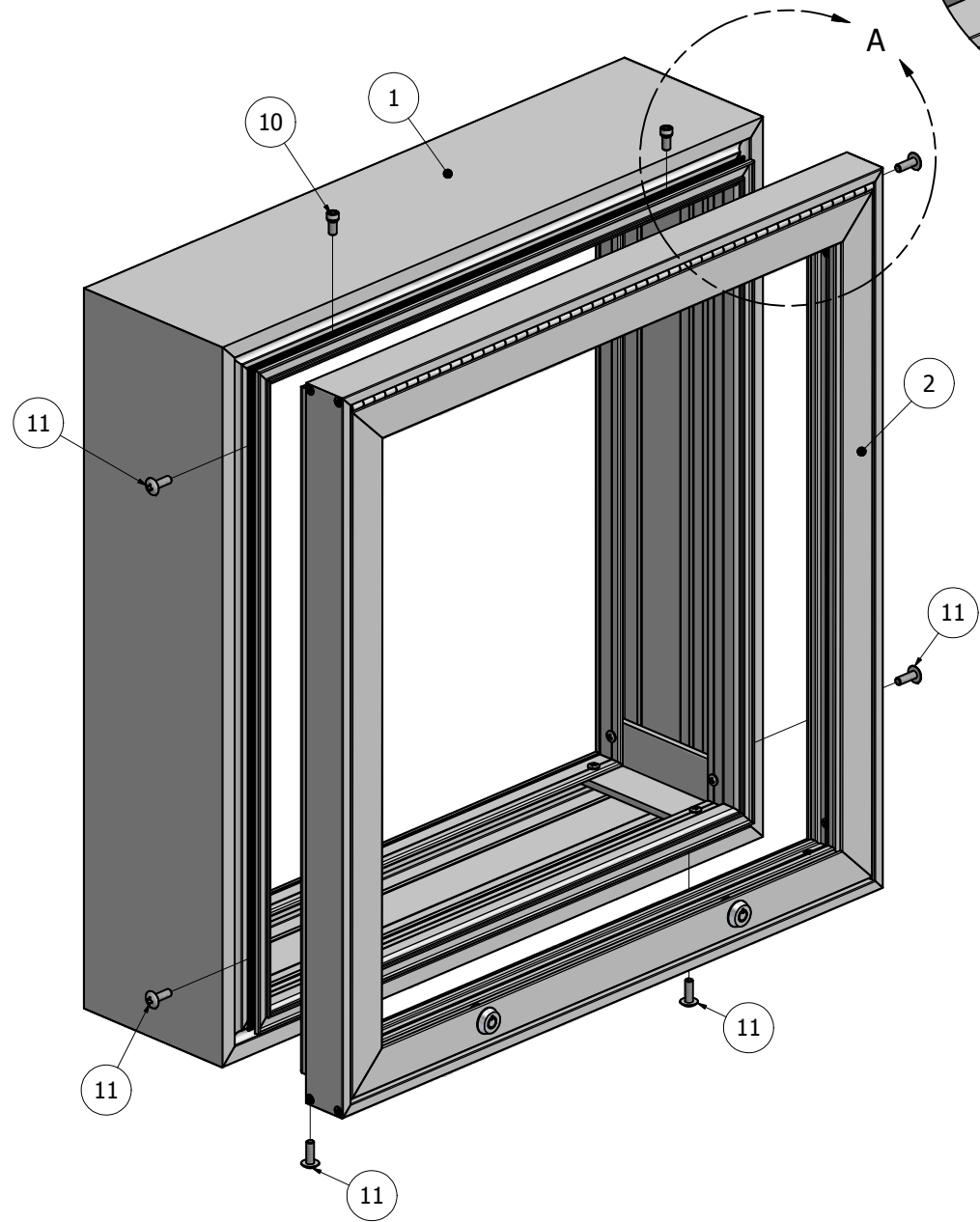
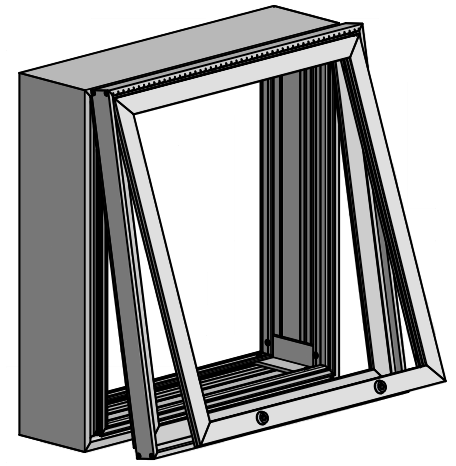

Drive the hinge screw down into the body so the head of the screw is under the retainer flange as shown.

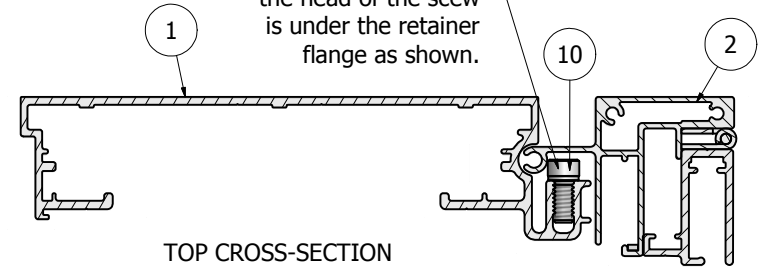

TOP CROSS-SECTION

**NOTE: PRE-CUT KITS ARE NOT PRE-DRILLED.**  
(Holes shown in this drawing are for reference only. Drilling of pilot holes are to be done by fabricator.)

THIS DRAWING WAS CREATED AT NO CHARGE TO ASSIST YOU IN VISUALIZING OUR PROPOSAL. THE DRAWING HEREIN IS THE PROPERTY OF SIGNCOMP. PERMISSION TO COPY OR REVISE THIS DRAWING OR TO USE THIS DRAWING FOR PRODUCTION IS STRICTLY PROHIBITED AND CAN ONLY BE COPIED, REVISED OR USED FOR PRODUCTION WITH THE EXPRESSED WRITTEN PERMISSION OF SIGNCOMP.			
DRAWN	Sarah	3/20/2012	
Centroid X:	0.000 in	TITLE	
Centroid Y:	0.000 in		
Principal Moments Ix:	0.000 in^4	Single Face Body w/ Small Inner and Outer Frame Retainer - Assembly	
Principal Moments Iy:	0.000 in^4		
Section Modulus Ix:	0.000 in^3	DWG NO	REV
Section Modulus Iy:	0.000 in^3	<b>KSF-99-42</b>	
SHEET 1 OF 1			

Parts List			
ITEM	PART #	DESCRIPTION	NOTES
1	2025	Single Face Body	Top & Bottom
2	2025	Single Face Body	Sides
3	5322	Single Face Body Corner Angle	
13	5218	Corner Angle Screw	Drill 5/32" Pilot Hole

Ship To:  
Order Number:

D  
C  
B  
A

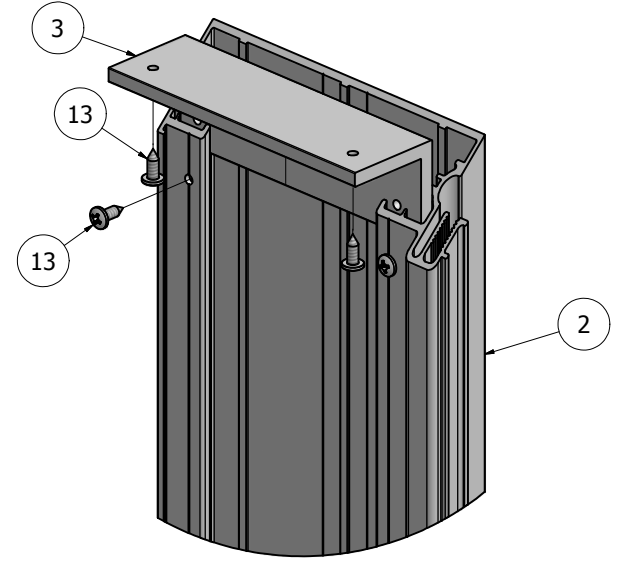
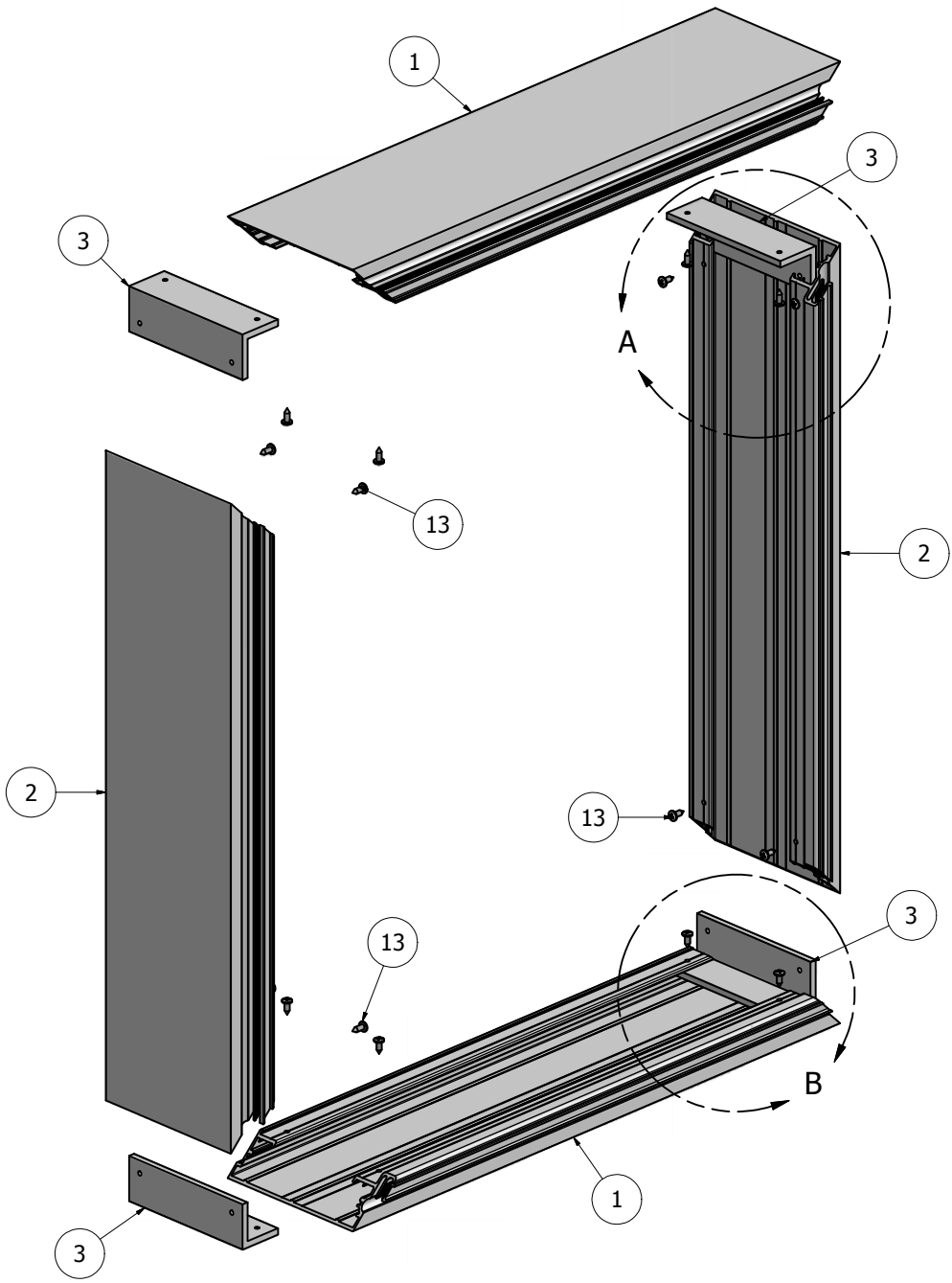

DETAIL A

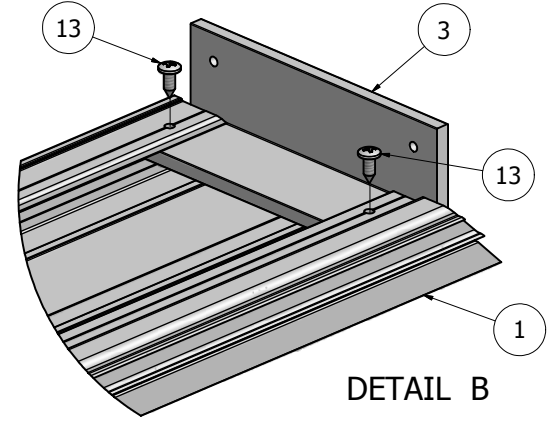

DETAIL B

**NOTE: PRE-CUT KITS ARE NOT PRE-DRILLED.**  
(Holes shown in this drawing are for reference only.  
Drilling of pilot holes are to be done by fabricator.)

THIS DRAWING WAS CREATED AT NO CHARGE TO ASSIST YOU IN VISUALIZING OUR PROPOSAL. THE DRAWING HEREIN IS THE PROPERTY OF SIGNCOMP. PERMISSION TO COPY OR REVISE THIS DRAWING OR TO USE THIS DRAWING FOR PRODUCTION IS STRICTLY PROHIBITED AND CAN ONLY BE COPIED, REVISED OR USED FOR PRODUCTION WITH THE EXPRESSED WRITTEN PERMISSION OF SIGNCOMP.		
DRAWN	Sarah	3/2/2012
Centroid X:	0.000 in	
Centroid Y:	0.000 in	
Principal Moments Ix:	0.000 in <sup>4</sup>	
Principal Moments Iy:	0.000 in <sup>4</sup>	
Section Modulus Ix:	0.000 in <sup>3</sup>	
Section Modulus Iy:	0.000 in <sup>3</sup>	
<h1 style="text-align: center;">SignComp</h1>		TITLE
		Single Face Body - Assembly
DWG NO		REV
<b>K2025</b>		
SHEET 1 OF 1		

D  
C  
B  
A

4 3 2 1

4 3 2 1

Parts List			
ITEM	PART#	DESCRIPTION	NOTES
1	2099	Inner Frame Retainer	Sides
2	2099	Inner Frame Retainer	Top & Bottom
3	5210	Corner Key	
23	5241	Inner Frame Retainer Corner Screw	Drill a #8 counter sink

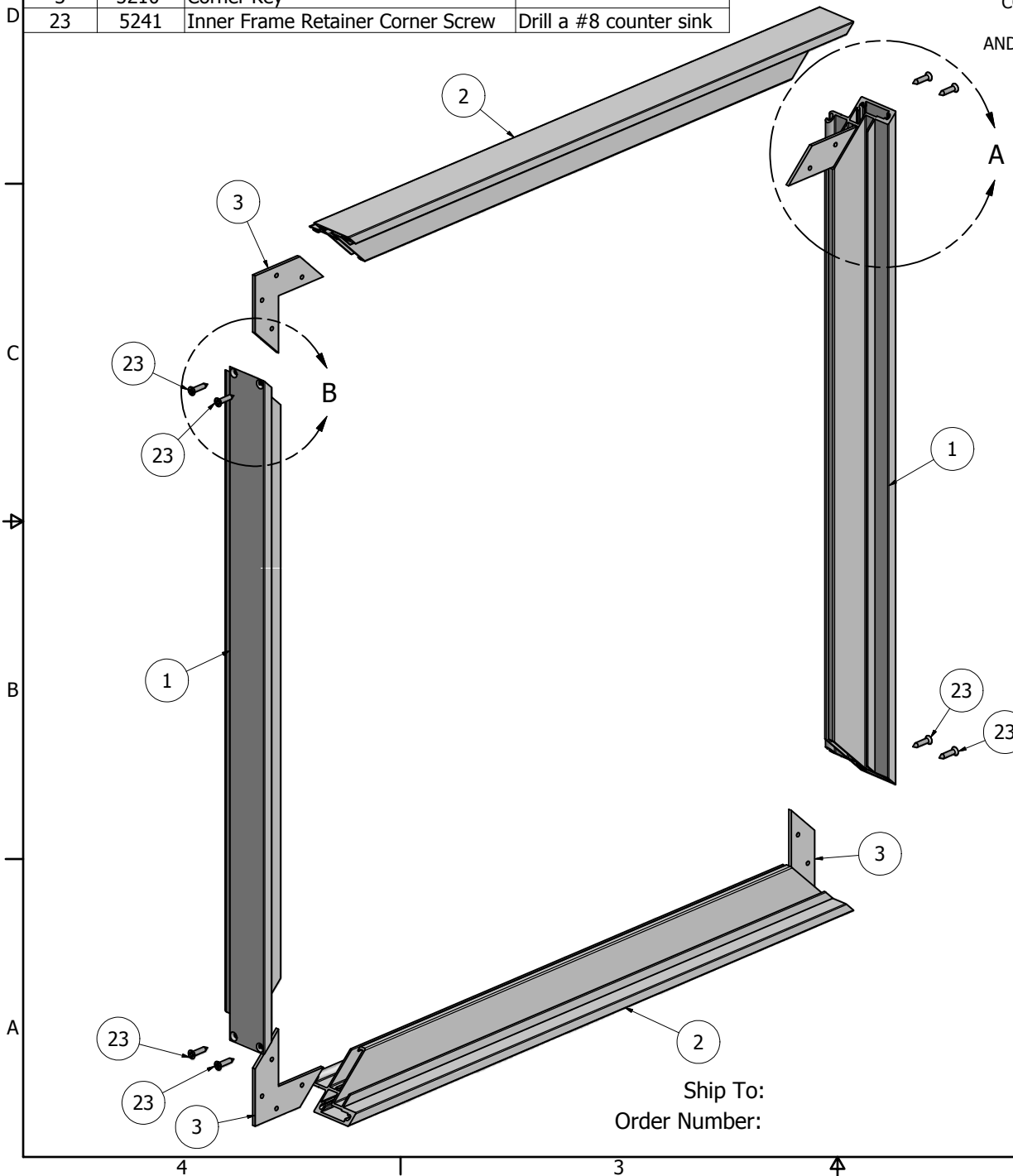

CORNER KEY HELPS  
ALIGN THE MITRE  
AND ADDS STRENGTH

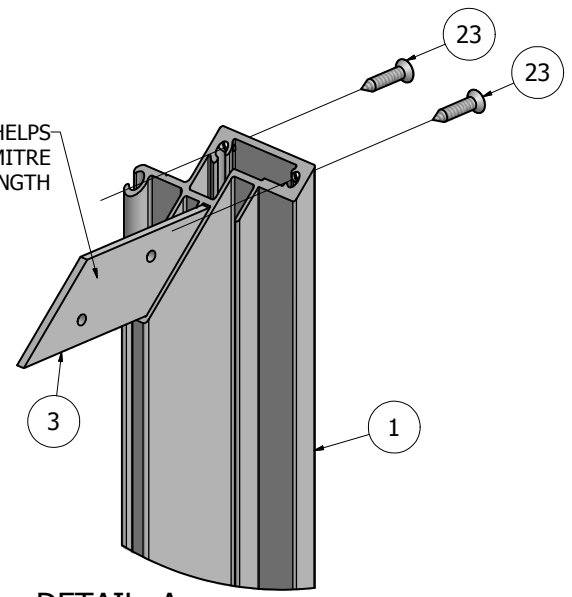

DETAIL A

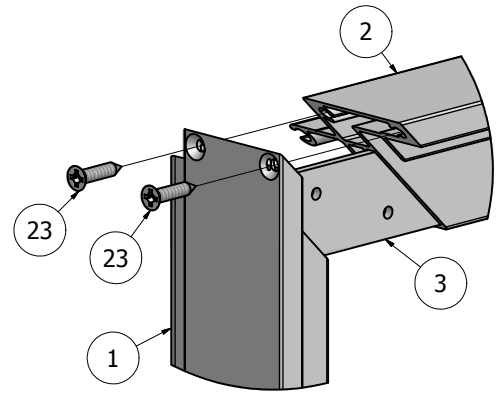

DETAIL B

**NOTE: PRE-CUT KITS ARE NOT PRE-DRILLED.**  
(Holes shown in this drawing are for reference only.  
Drilling of pilot holes are to be done by fabricator.)

THIS DRAWING WAS CREATED AT NO CHARGE TO ASSIST YOU IN VISUALIZING OUR PROPOSAL. THE DRAWING HEREIN IS THE PROPERTY OF SIGNCOMP. PERMISSION TO COPY OR REVISE THIS DRAWING OR TO USE THIS DRAWING FOR PRODUCTION IS STRICTLY PROHIBITED AND CAN ONLY BE COPIED, REVISED OR USED FOR PRODUCTION WITH THE EXPRESSED WRITTEN PERMISSION OF SIGNCOMP.

DRAWN	Sarah	3/7/2012	<b>SignComp</b>
Centroid X:	0.000 in		
Centroid Y:	0.000 in		Inner Frame Retainer - Assembly
Principal Moments Ix:	0.000 in <sup>4</sup>		
Principal Moments Iy:	0.000 in <sup>4</sup>		DWG NO <b>K2099</b> REV
Section Modulus Ix:	0.000 in <sup>3</sup>		
Section Modulus Iy:	0.000 in <sup>3</sup>		SHEET 1 OF 1

Ship To:  
Order Number:

Parts List			
ITEM	PART #	DESCRIPTION	NOTES
1	1942	2Part Outer Frame	Top & Bottom
2	1942	2Part Outer Frame	Ends
3	5975	2Part Outer Frame Corner Angle	
30	5990	2Part Outer Frame Corner Angle Screw	Drill #8 Counter Sink

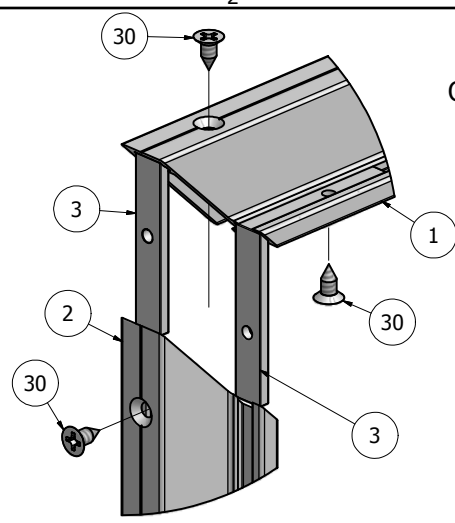
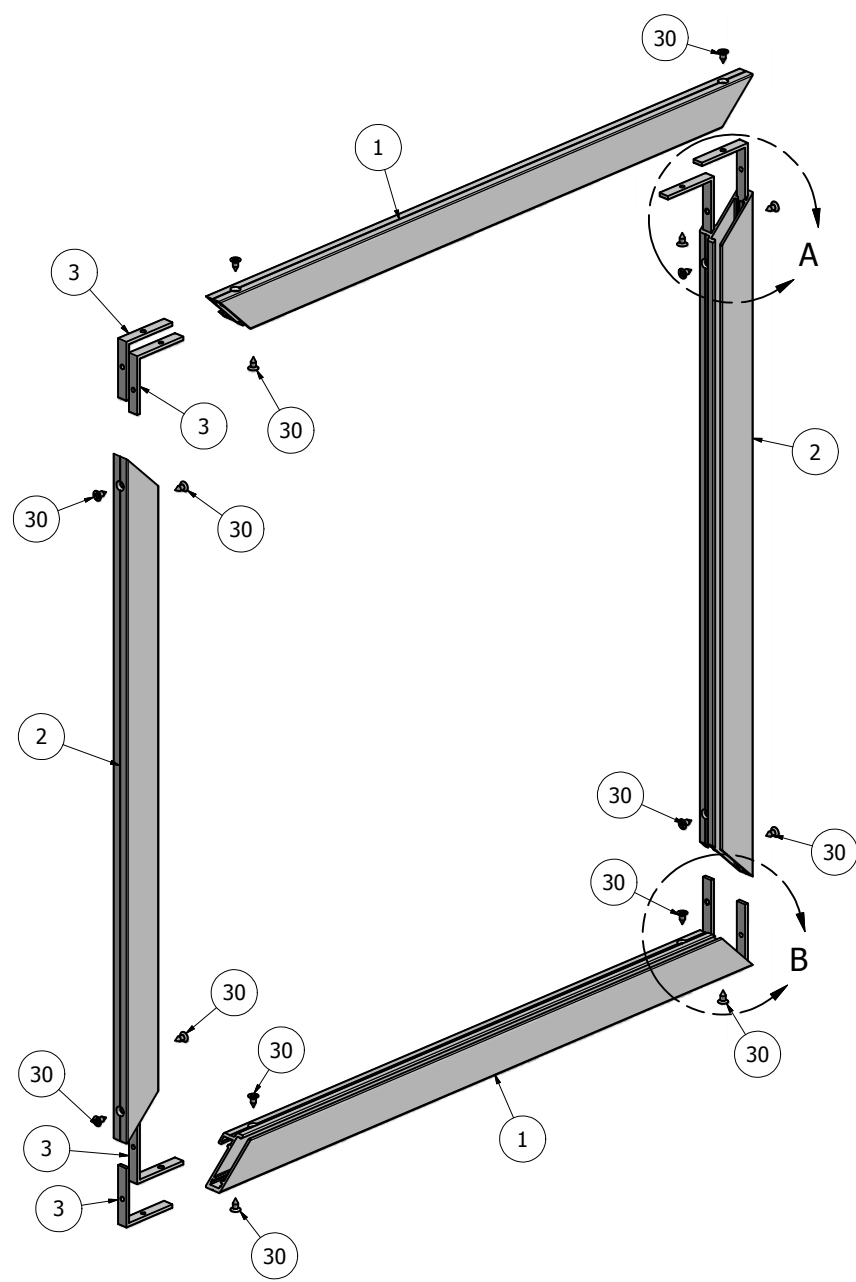

DETAIL B  
BACK VIEW

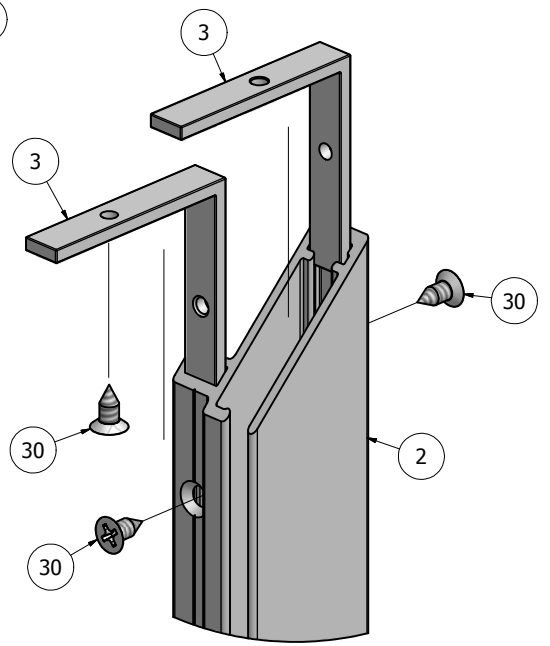

DETAIL A

Ship To:  
Order Number:

**NOTE: PRE-CUT KITS ARE NOT PRE-DRILLED.**  
(Holes shown in this drawing are for reference only.  
Drilling of pilot holes are to be done by fabricator.)

THIS DRAWING WAS CREATED AT NO CHARGE TO ASSIST YOU IN VISUALIZING OUR PROPOSAL. THE DRAWING HEREIN IS THE PROPERTY OF SIGNCOMP. PERMISSION TO COPY OR REVISE THIS DRAWING OR TO USE THIS DRAWING FOR PRODUCTION IS STRICTLY PROHIBITED AND CAN ONLY BE COPIED, REVISED OR USED FOR PRODUCTION WITH THE EXPRESSED WRITTEN PERMISSION OF SIGNCOMP.

DRAWN	Steve	6/17/2010	<h1>SignComp</h1>		
CHECKED					
QA					
MFG					
APPROVED			TITLE <b>2Part Outer Frame</b>		
			SIZE C	DWG NO K1942	REV
			SCALE	SHEET 1 OF 1	

Parts List			
ITEM	PART #	DESCRIPTION	NOTES
1	1942	2Part Outer Frame	
2		Hinge Fastener	1/8" Pop Rivet or #8 Counter Sunk Screw
3	5996	2Part Hinge	
4	5994	2Part Lock	Drill 3/4" Hole - See Detail "A"
5		Lock Nut	
6		Lock Washer	
7		Cam	
8		Cam Nut	
31	5990	Hinge Screw	

Ship To:  
Order Number:

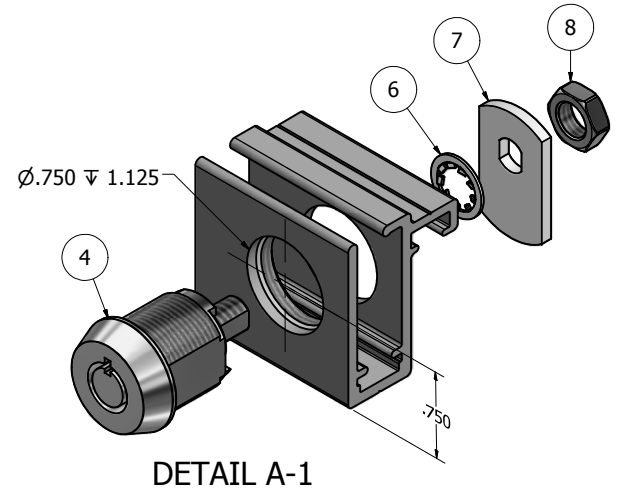

DETAIL A-1

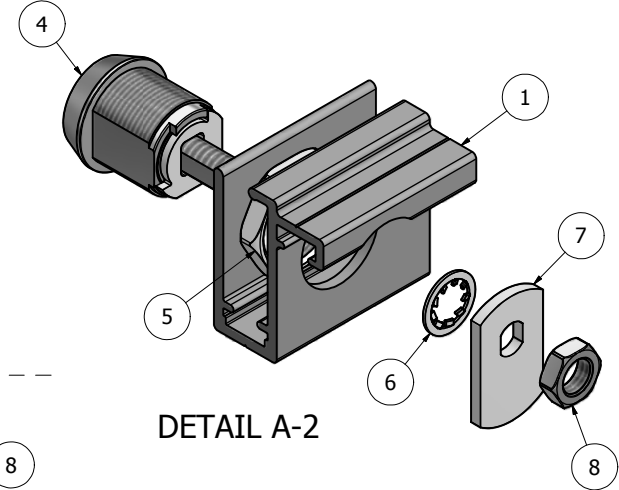

DETAIL A-2

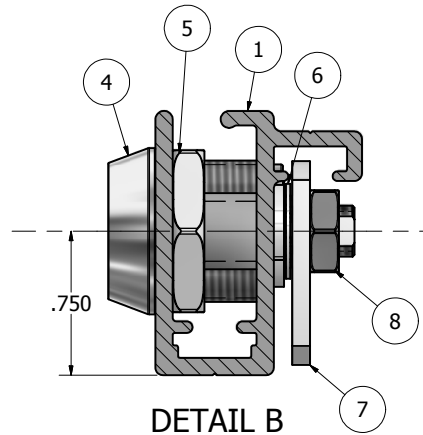

DETAIL B

**NOTE: PRE-CUT KITS ARE NOT PRE-DRILLED.**  
(Holes shown in this drawing are for reference only.  
Drilling of pilot holes are to be done by fabricator.)

THIS DRAWING WAS CREATED AT NO CHARGE TO ASSIST YOU IN VISUALIZING OUR PROPOSAL. THE DRAWING HEREIN IS THE PROPERTY OF SIGNCOMP. PERMISSION TO COPY OR REVISE THIS DRAWING OR TO USE THIS DRAWING FOR PRODUCTION IS STRICTLY PROHIBITED AND CAN ONLY BE COPIED, REVISED OR USED FOR PRODUCTION WITH THE EXPRESSED WRITTEN PERMISSION OF SIGNCOMP.

DRAWN	6/17/2010	<h1>SignComp</h1>	
CHECKED			
QA		TITLE	
MFG		2Part Outer Frame - 2Part Hinge - 2Part Lock - Assembly	
APPROVED		SIZE	DWG NO
		C	K1942-5994-96
		SCALE	REV

**TIP:** High bond tape or bonding agents can be used to help secure the hinge to the frame and assist in the installation of the hinge. Be careful not to get the tape on the barrel of the hinge. To do so may cause the hinge not to open properly.

Parts List			
ITEM	PART#	DESCRIPTION	NOTES
1	K2099	Inner Frame Retainer	Assembly
2	K1942	2Part Outer Frame	Assembly
31	5990	2Part Large/Small Hinge Screw	1/8" Pop Rivet or #8 Counter Sink Fastener

Ship To:  
Order Number:

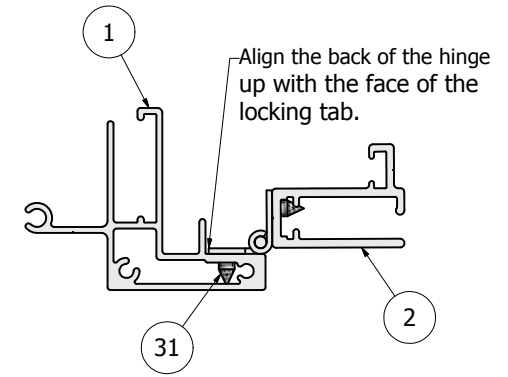
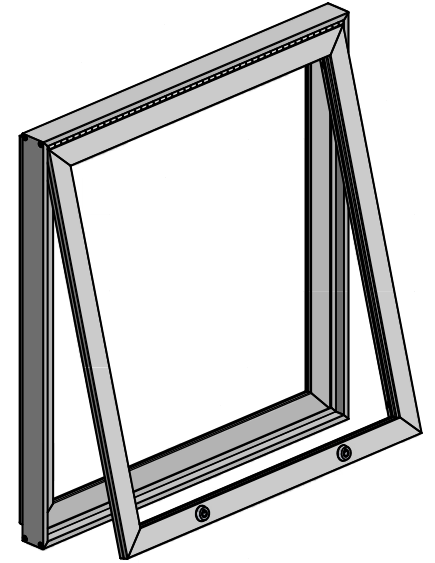
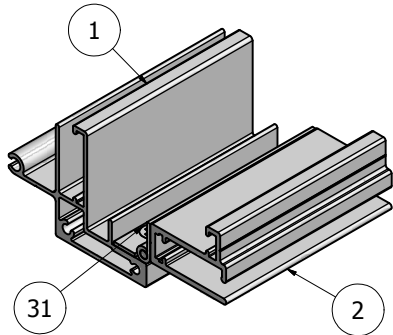
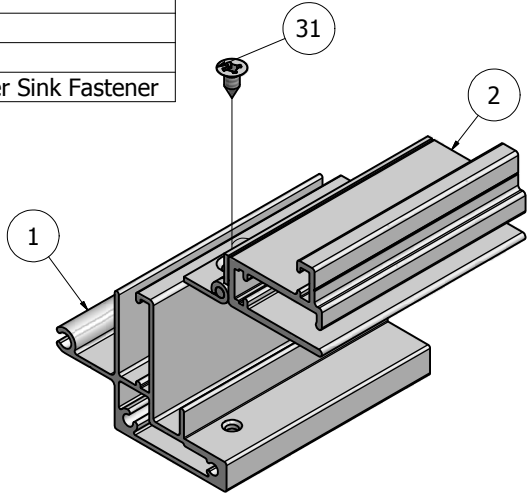
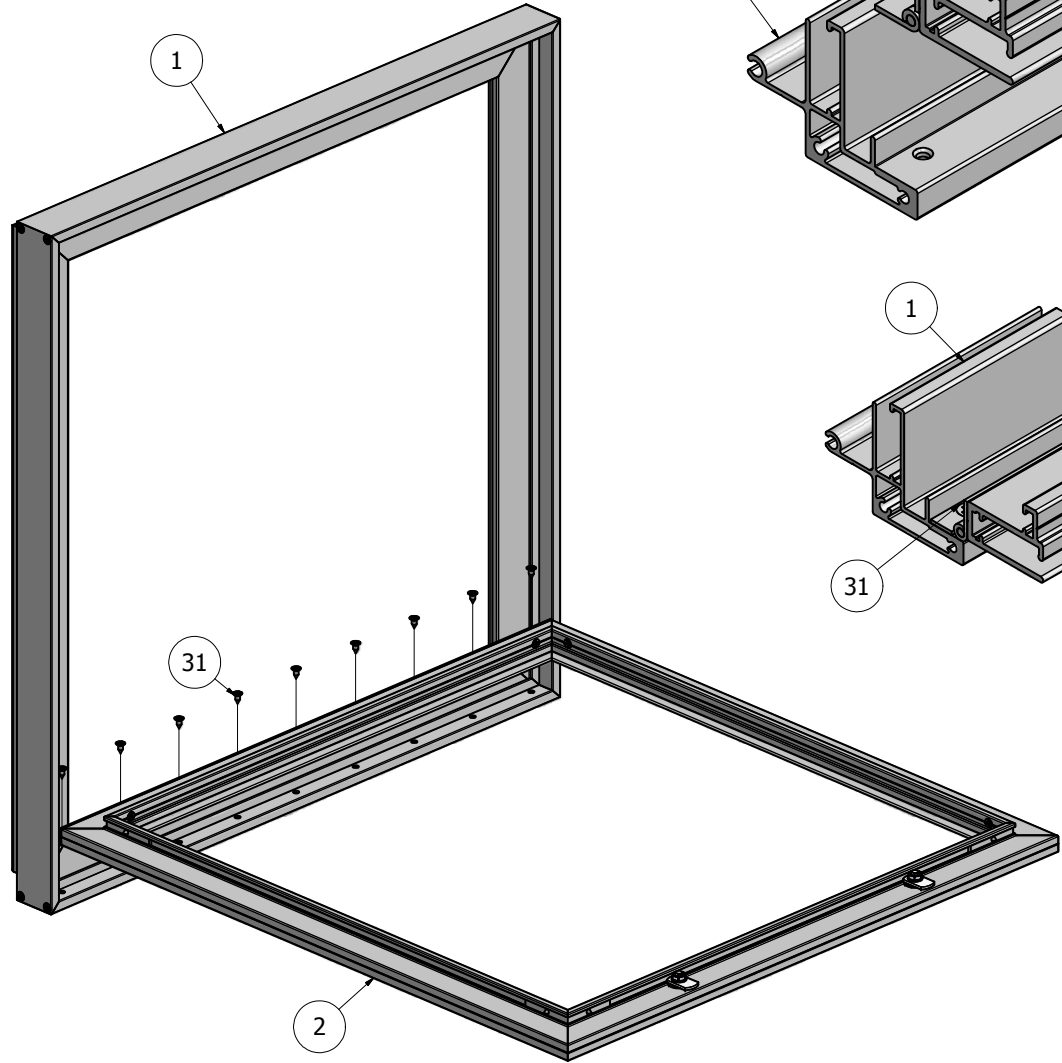

**NOTE: PRE-CUT KITS ARE NOT PRE-DRILLED.**  
(Holes shown in this drawing are for reference only.  
Drilling of pilot holes are to be done by fabricator.)

THIS DRAWING WAS CREATED AT NO CHARGE TO ASSIST YOU IN VISUALIZING OUR PROPOSAL. THE DRAWING HEREIN IS THE PROPERTY OF SIGNCOMP. PERMISSION TO COPY OR REVISE THIS DRAWING OR TO USE THIS DRAWING FOR PRODUCTION IS STRICTLY PROHIBITED AND CAN ONLY BE COPIED, REVISED OR USED FOR PRODUCTION WITH THE EXPRESSED WRITTEN PERMISSION OF SIGNCOMP.

DRAWN	Sarah	3/9/2012	<b>SignComp</b>
Centroid X:	0.000 in		
Centroid Y:	0.000 in		
Principal Moments Ix:	0.000 in <sup>4</sup>		Inner Frame Retainer and 2 Part Outer Frame - Assembly
Principal Moments Iy:	0.000 in <sup>4</sup>		
Section Modulus Ix:	0.000 in <sup>3</sup>		DWG NO
Section Modulus Iy:	0.000 in <sup>3</sup>		<b>K2099-1942</b>
			REV

**TIP:** High bond tape or bonding agents can be used to help secure the hinge to the frame and assist in the installation of the hinge. Be careful not to get the tape on the barrel of the hinge. Doing so may cause the hinge not to open properly.