

Parts List			
ITEM	PART#	DESCRIPTION	NOTES
1	K2025	Single Face Body	Assembly
2	K2085/95	Tension Frame / Bleed Cover	Assembly
10	5170	Hinge Screw	Drill 3/8" pilot hole
11	5180	Closure Screw	Drill 5/16" pilot hole

Ship To:  
Order Number:

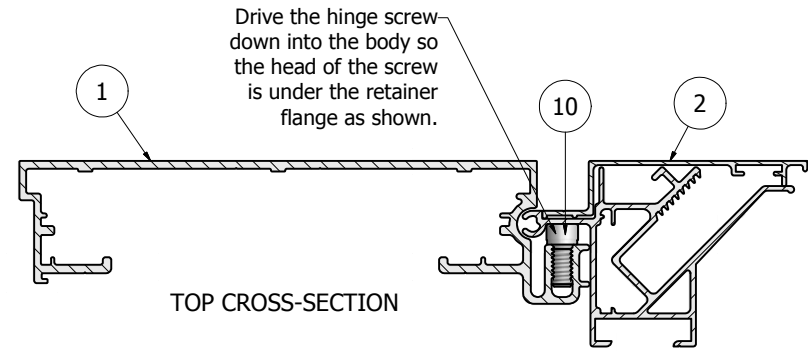
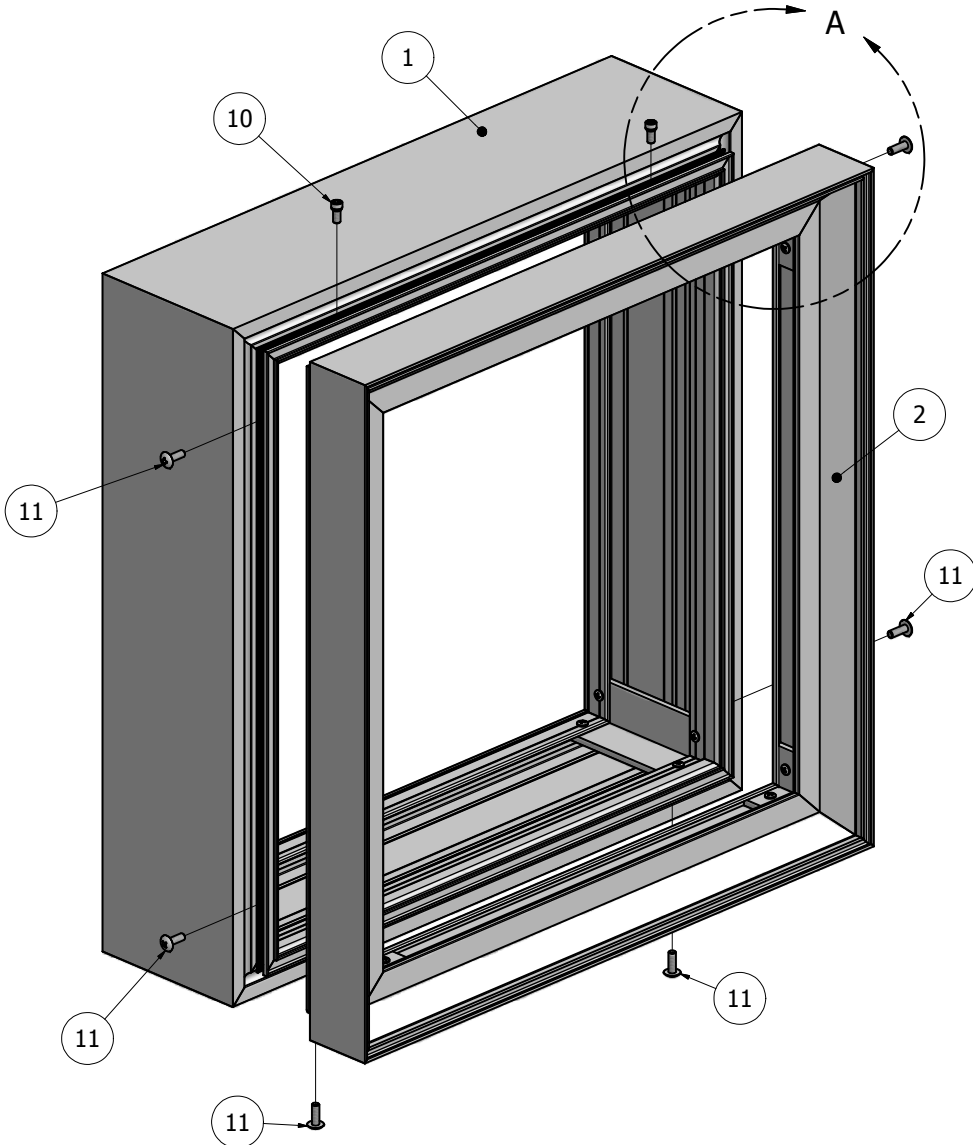
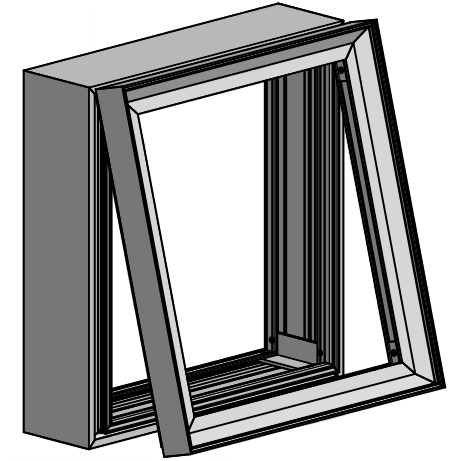
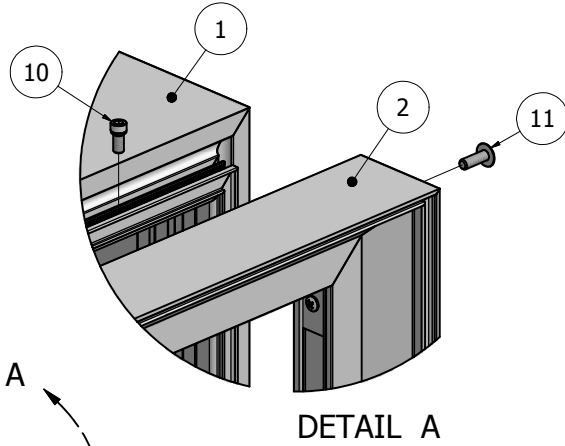

**NOTE: PRE-CUT KITS ARE NOT PRE-DRILLED.**  
(Holes shown in this drawing are for reference only. Drilling of pilot holes are to be done by fabricator.)

THIS DRAWING WAS CREATED AT NO CHARGE TO ASSIST YOU IN VISUALIZING OUR PROPOSAL. THE DRAWING HEREIN IS THE PROPERTY OF SIGNCOMP. PERMISSION TO COPY OR REVISE THIS DRAWING OR TO USE THIS DRAWING FOR PRODUCTION IS STRICTLY PROHIBITED AND CAN ONLY BE COPIED, REVISED OR USED FOR PRODUCTION WITH THE EXPRESSED WRITTEN PERMISSION OF SIGNCOMP.

DRAWN	Sarah	3/8/2012	<b>SignComp</b>
Centroid X:	0.000 in	TITLE	
Centroid Y:	0.000 in	Single Face Body w/ Tension Frame and Bleed Cover - Assembly	
Principal Moments Ix:	0.000 in <sup>4</sup>	DWG NO	REV
Principal Moments Iy:	0.000 in <sup>4</sup>	<b>KSF-85 with 2095</b>	
Section Modulus Ix:	0.000 in <sup>3</sup>	SHEET 1 OF 1	
Section Modulus Iy:	0.000 in <sup>3</sup>		

Parts List			
ITEM	PART #	DESCRIPTION	NOTES
1	2025	Single Face Body	Top & Bottom
2	2025	Single Face Body	Sides
3	5322	Single Face Body Corner Angle	
13	5218	Corner Angle Screw	Drill 5/32" Pilot Hole

Ship To:  
Order Number:

D

C

B

A

A

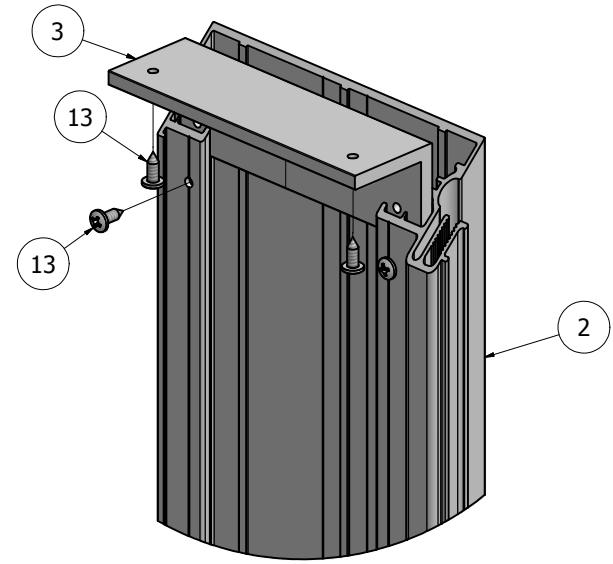
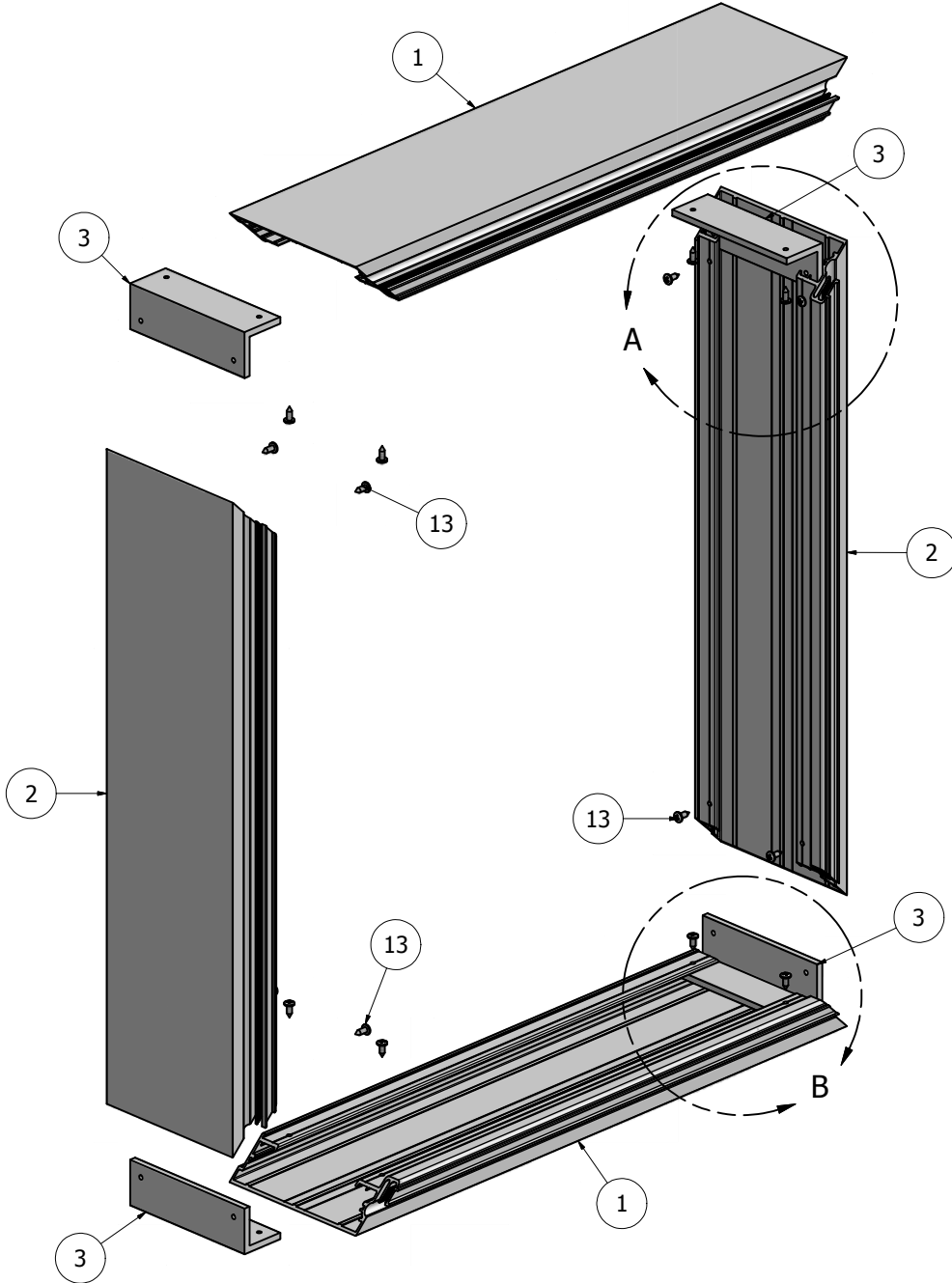

DETAIL A

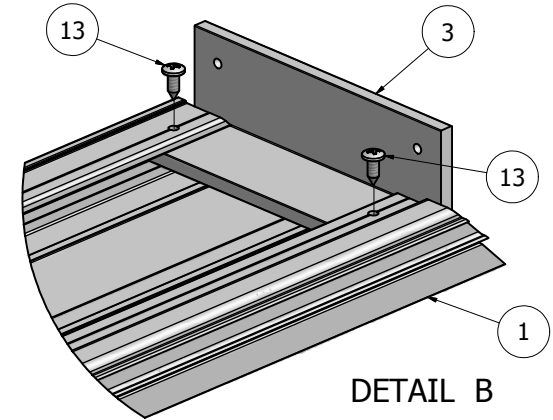

DETAIL B

**NOTE: PRE-CUT KITS ARE NOT PRE-DRILLED.**  
(Holes shown in this drawing are for reference only.  
Drilling of pilot holes are to be done by fabricator.)

THIS DRAWING WAS CREATED AT NO CHARGE TO ASSIST YOU IN VISUALIZING OUR PROPOSAL. THE DRAWING HEREIN IS THE PROPERTY OF SIGNCOMP. PERMISSION TO COPY OR REVISE THIS DRAWING OR TO USE THIS DRAWING FOR PRODUCTION IS STRICTLY PROHIBITED AND CAN ONLY BE COPIED, REVISED OR USED FOR PRODUCTION WITH THE EXPRESSED WRITTEN PERMISSION OF SIGNCOMP.

DRAWN	Sarah	3/2/2012	<h1>SignComp</h1>	
Centroid X:	0.000 in	TITLE		
Centroid Y:	0.000 in	Single Face Body - Assembly		
Principal Moments Ix:	0.000 in <sup>4</sup>	DWG NO	<b>K2025</b>	REV
Principal Moments Iy:	0.000 in <sup>4</sup>			
Section Modulus Ix:	0.000 in <sup>3</sup>			
Section Modulus Iy:	0.000 in <sup>3</sup>			

Parts List			
ITEM	PART#	DESCRIPTION	NOTES
1	2085	Tension Frame	Top & Bottom
2	2085	Tension Frame	Sides
3	5305	Frame corner Angle	
4	5210	Corner Key	
13	5218	Corner Angle Screw	Drill 5/32" pilot hole

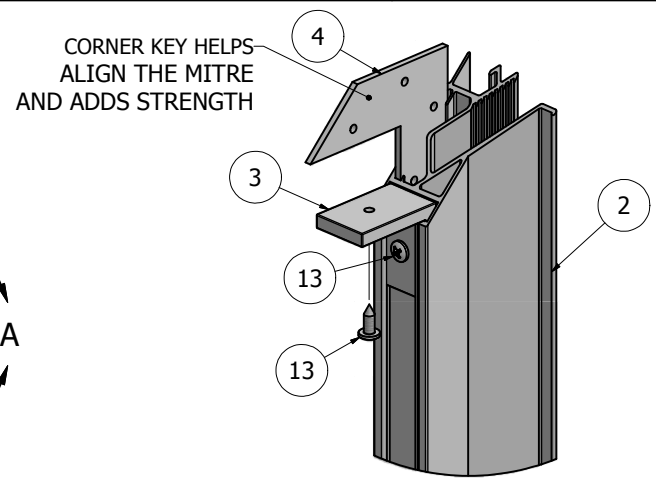
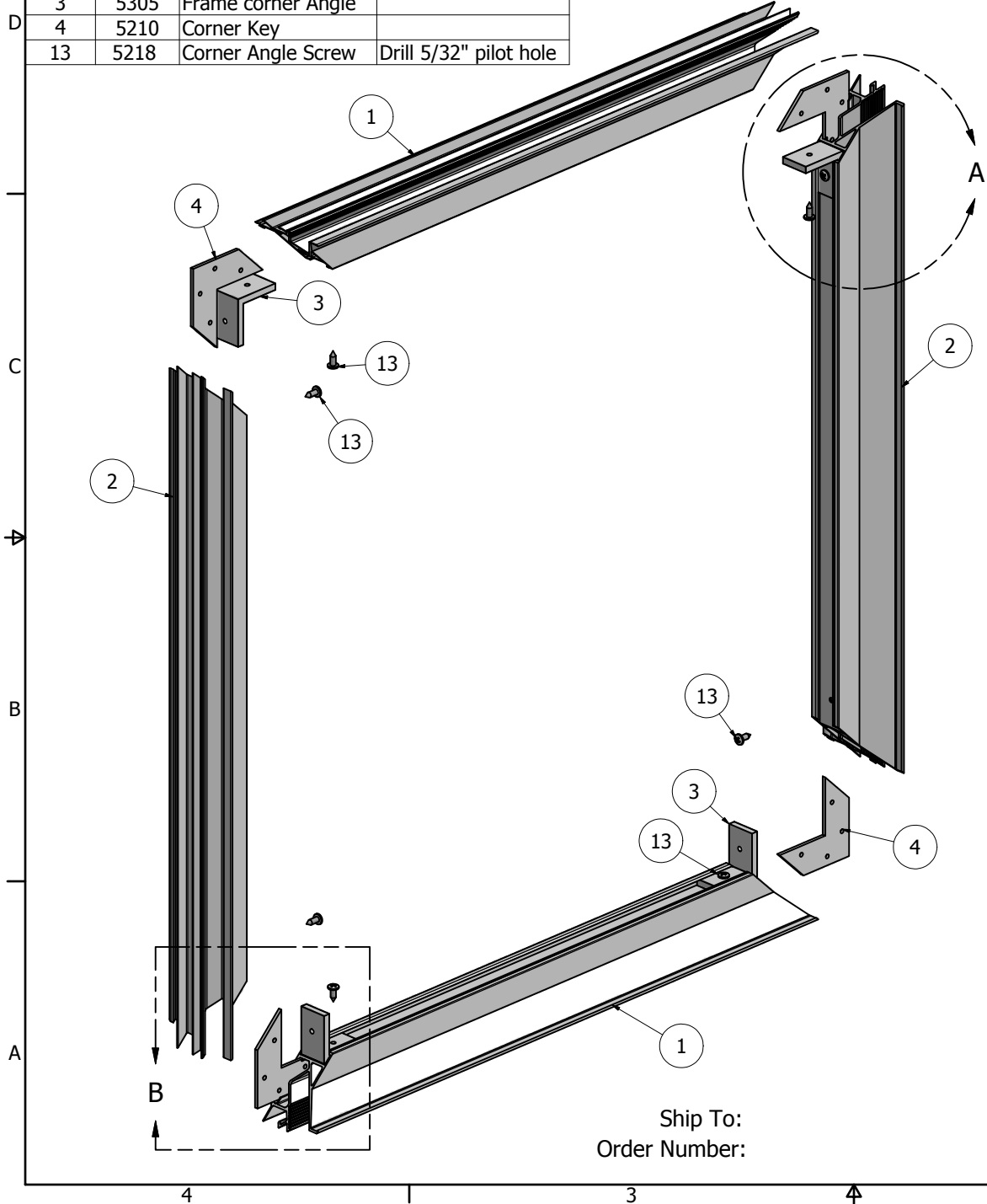

DETAIL A

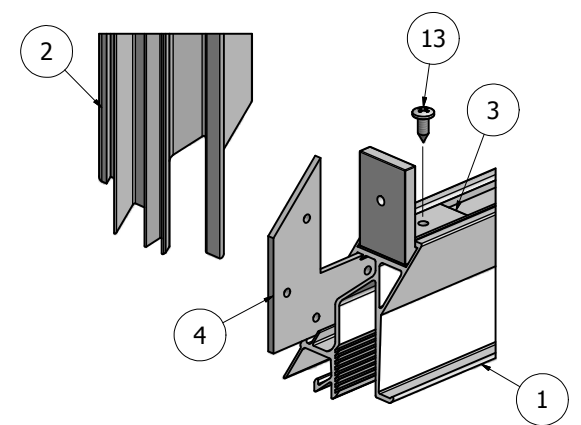

DETAIL B

**NOTE: PRE-CUT KITS ARE NOT PRE-DRILLED.**  
 (Holes shown in this drawing are for reference only.  
 Drilling of pilot holes are to be done by fabricator.)

THIS DRAWING WAS CREATED AT NO CHARGE TO ASSIST YOU IN VISUALIZING OUR PROPOSAL. THE DRAWING HEREIN IS THE PROPERTY OF SIGNCOMP. PERMISSION TO COPY OR REVISE THIS DRAWING OR TO USE THIS DRAWING FOR PRODUCTION IS STRICTLY PROHIBITED AND CAN ONLY BE COPIED, REVISED OR USED FOR PRODUCTION WITH THE EXPRESSED WRITTEN PERMISSION OF SIGNCOMP.				
DRAWN	Sarah	3/6/2012		
Centroid X:	0.000 in	TITLE		
Centroid Y:	0.000 in			
Principal Moments Ix:	0.000 in <sup>4</sup>	Bleed Tension Frame - Assembly		
Principal Moments Iy:	0.000 in <sup>4</sup>			
Section Modulus Ix:	0.000 in <sup>3</sup>	DWG NO	<b>K2085</b>	REV
Section Modulus Iy:	0.000 in <sup>3</sup>	SHEET 1 OF 1		

Ship To:  
Order Number:

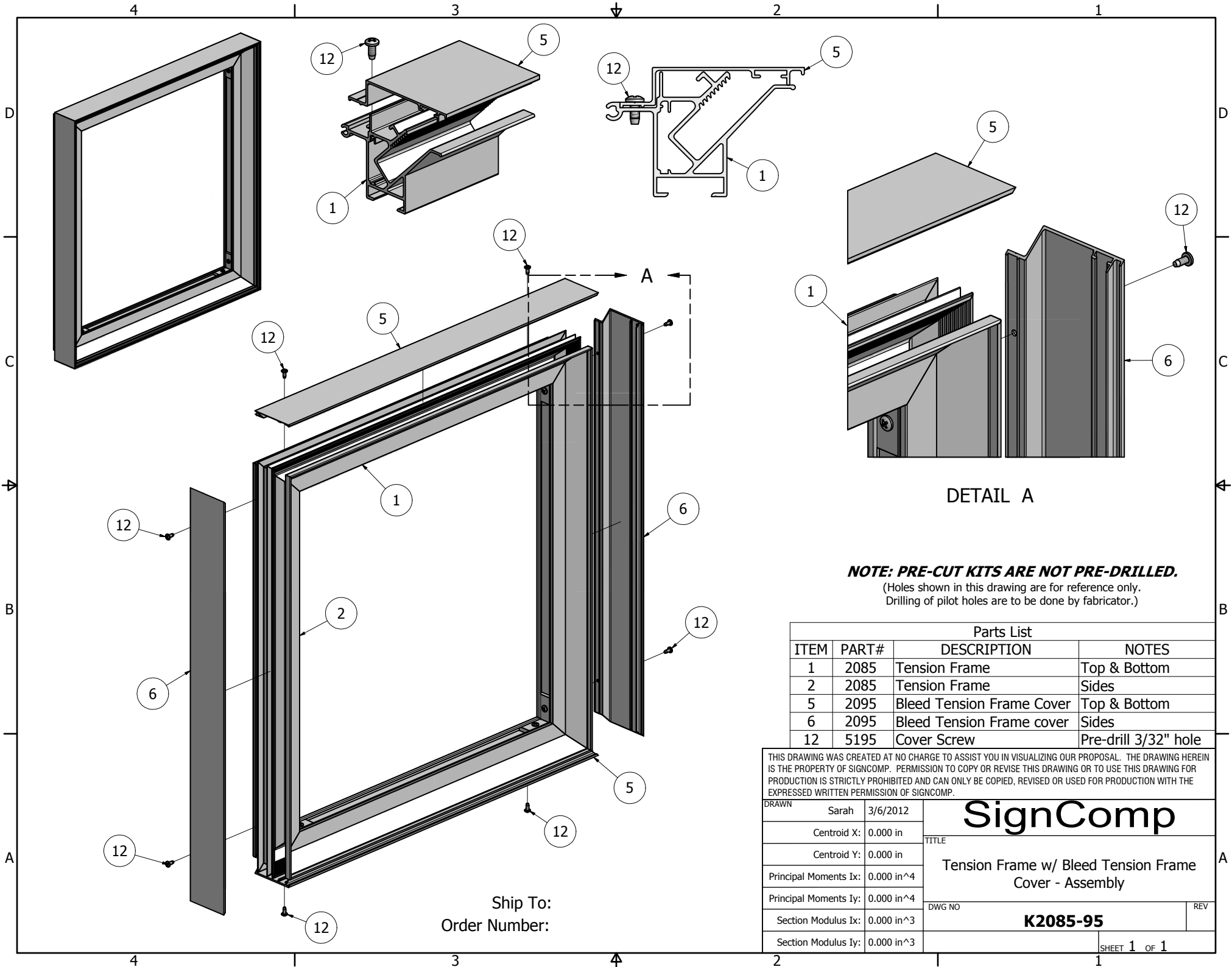

DETAIL A

**NOTE: PRE-CUT KITS ARE NOT PRE-DRILLED.**  
 (Holes shown in this drawing are for reference only.  
 Drilling of pilot holes are to be done by fabricator.)

Parts List			
ITEM	PART#	DESCRIPTION	NOTES
1	2085	Tension Frame	Top & Bottom
2	2085	Tension Frame	Sides
5	2095	Bleed Tension Frame Cover	Top & Bottom
6	2095	Bleed Tension Frame cover	Sides
12	5195	Cover Screw	Pre-drill 3/32" hole

THIS DRAWING WAS CREATED AT NO CHARGE TO ASSIST YOU IN VISUALIZING OUR PROPOSAL. THE DRAWING HEREIN IS THE PROPERTY OF SIGNCOMP. PERMISSION TO COPY OR REVISE THIS DRAWING OR TO USE THIS DRAWING FOR PRODUCTION IS STRICTLY PROHIBITED AND CAN ONLY BE COPIED, REVISED OR USED FOR PRODUCTION WITH THE EXPRESSED WRITTEN PERMISSION OF SIGNCOMP.

DRAWN	Sarah	3/6/2012	<b>SignComp</b>
Centroid X:	0.000 in		
Centroid Y:	0.000 in		TITLE Tension Frame w/ Bleed Tension Frame Cover - Assembly
Principal Moments Ix:	0.000 in <sup>4</sup>		
Principal Moments Iy:	0.000 in <sup>4</sup>		DWG NO <b>K2085-95</b>
Section Modulus Ix:	0.000 in <sup>3</sup>		
Section Modulus Iy:	0.000 in <sup>3</sup>		REV

Ship To:  
Order Number: