

Parts List			
ITEM	PART#	DESCRIPTION	NOTES
1	K2005	Wide Body	Assembly
2	K2097-41	Large Inner and Outer Frame Retainer	Assembly
10	5170	Hinge Screw	Drill 3/8" pilot hole
11	5180	Closure Screw	Drill 5/16" pilot hole

Ship To:
Order Number:

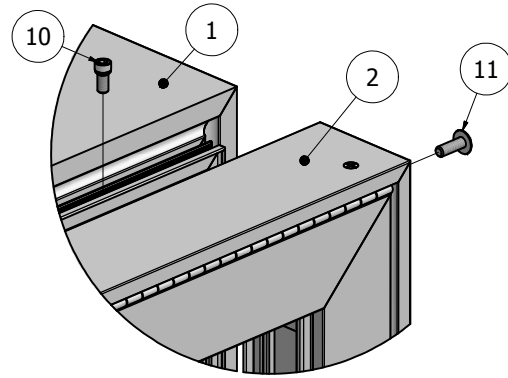

DETAIL A

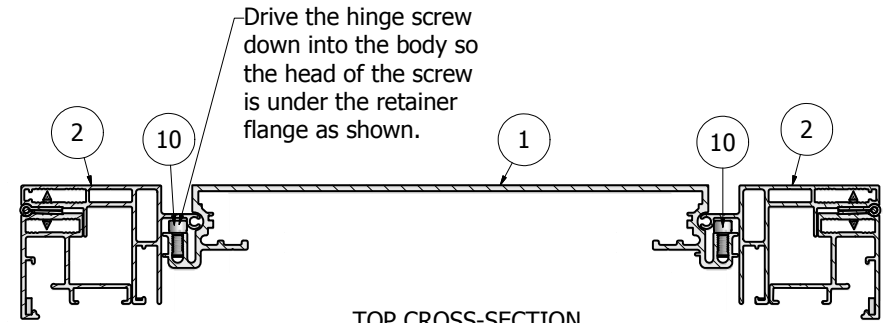
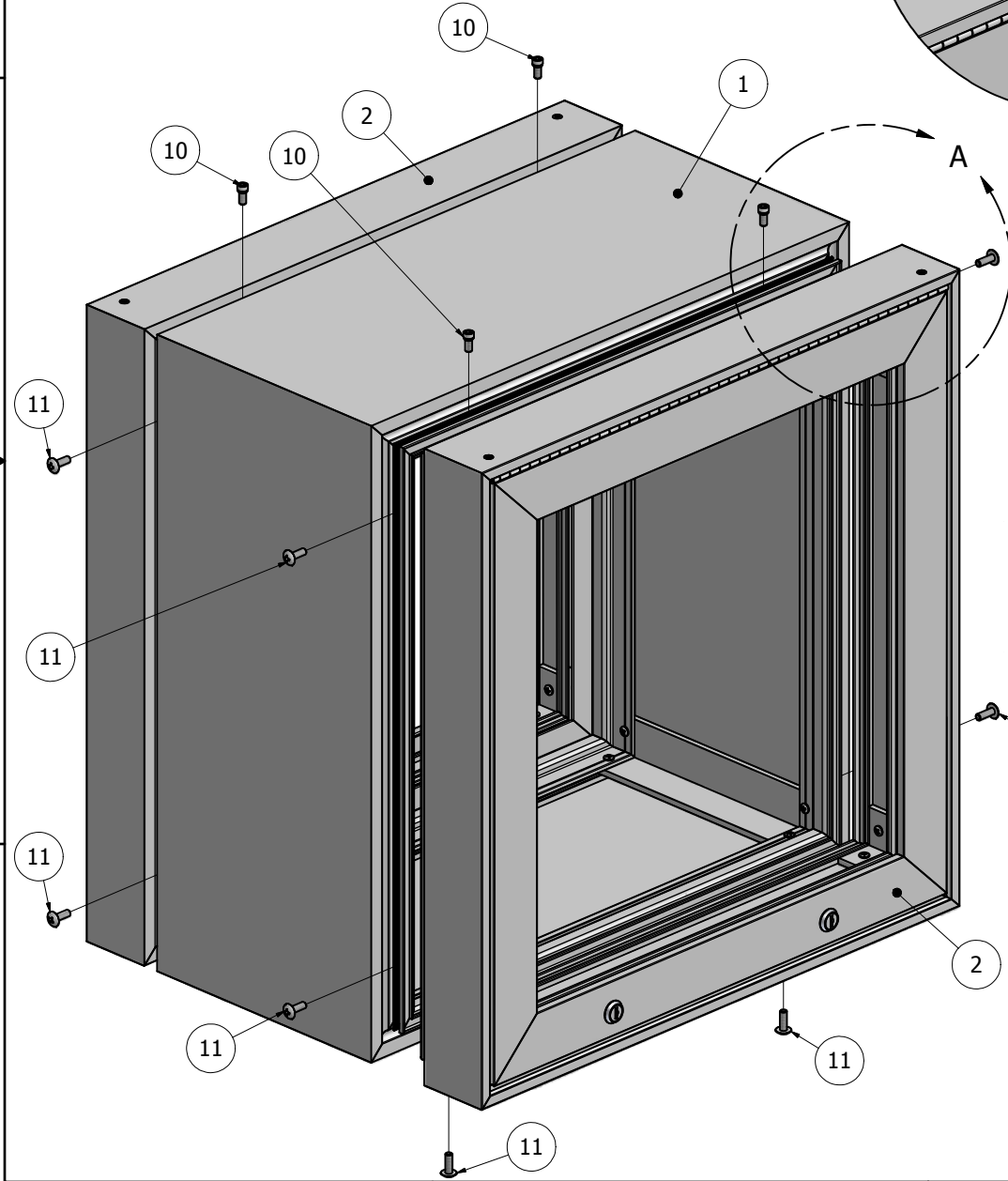
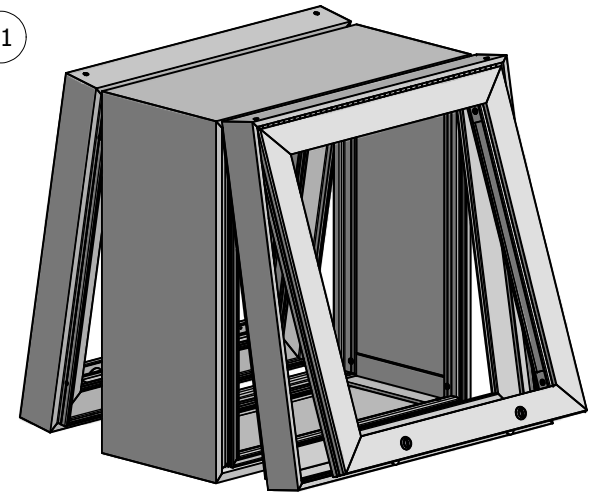

TOP CROSS-SECTION

NOTE: PRE-CUT KITS ARE NOT PRE-DRILLED.
(Holes shown in this drawing are for reference only.
Drilling of pilot holes are to be done by fabricator.)

THIS DRAWING WAS CREATED AT NO CHARGE TO ASSIST YOU IN VISUALIZING OUR PROPOSAL. THE DRAWING HEREIN IS THE PROPERTY OF SIGNCOMP. PERMISSION TO COPY OR REVISE THIS DRAWING OR TO USE THIS DRAWING FOR PRODUCTION IS STRICTLY PROHIBITED AND CAN ONLY BE COPIED, REVISED OR USED FOR PRODUCTION WITH THE EXPRESSED WRITTEN PERMISSION OF SIGNCOMP.

DRAWN	Sarah	3/23/2012
Centroid X:	0.000 in	
Centroid Y:	0.000 in	
Principal Moments Ix:	0.000 in ⁴	
Principal Moments Iy:	0.000 in ⁴	
Section Modulus Ix:	0.000 in ³	
Section Modulus Iy:	0.000 in ³	

SignComp

Wide Body w/ Large Inner and Outer Frame Retainer - Assembly

DWG NO **KWB-97-41** REV

Parts List			
ITEM	PART #	DESCRIPTION	NOTES
1	2005	Wide Body	Top & Bottom
2	2005	Wide Body	Sides
3	5312	Wide Body Corner Angle	
13	5218	Corner Angle Screw	Drill 5/32" pilot hole

Ship To:
Order Number:

D

C

B

B

A

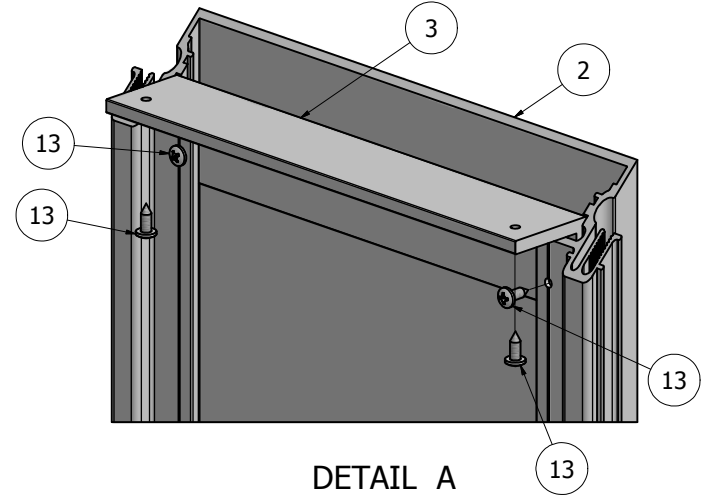
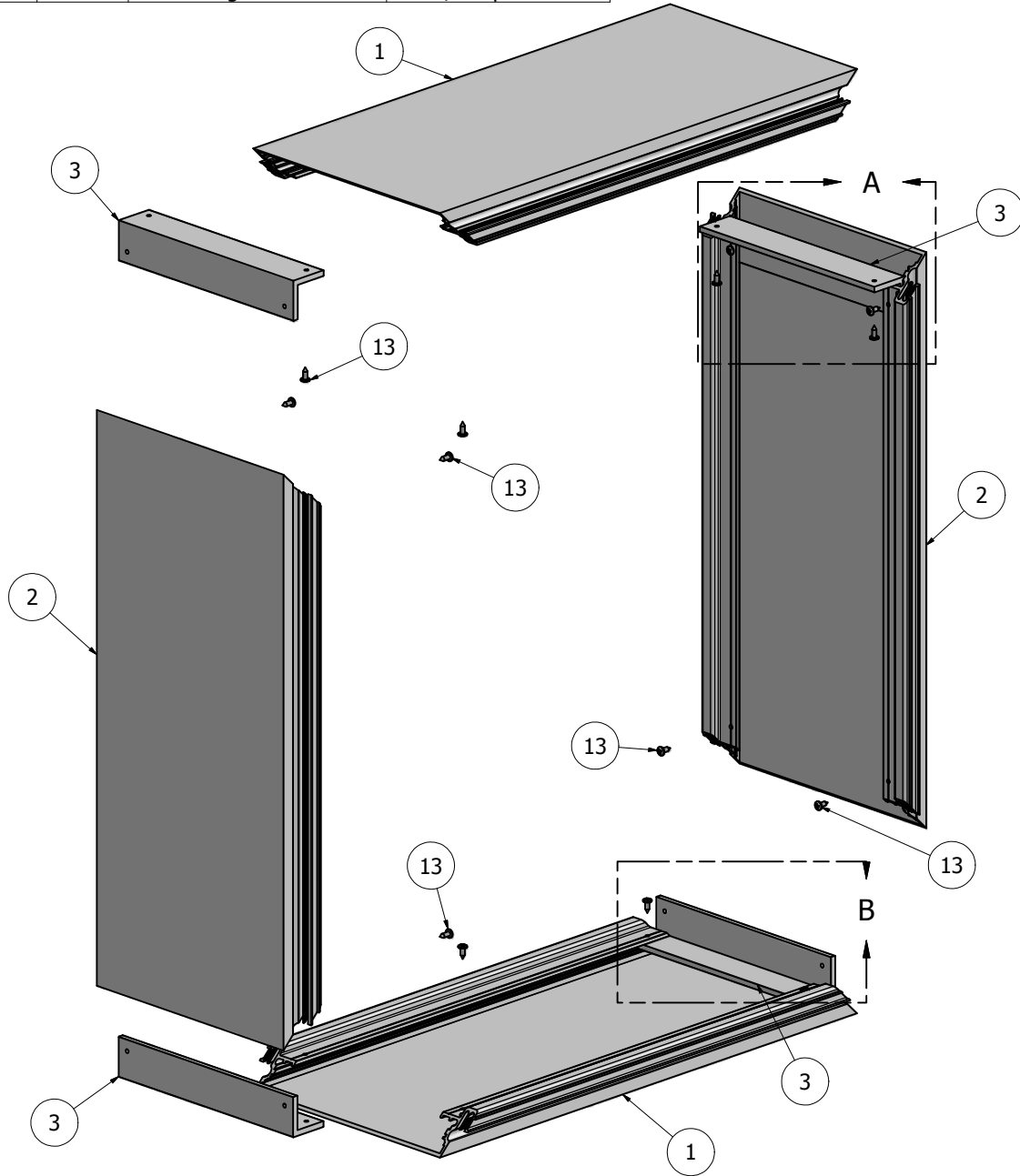

DETAIL A

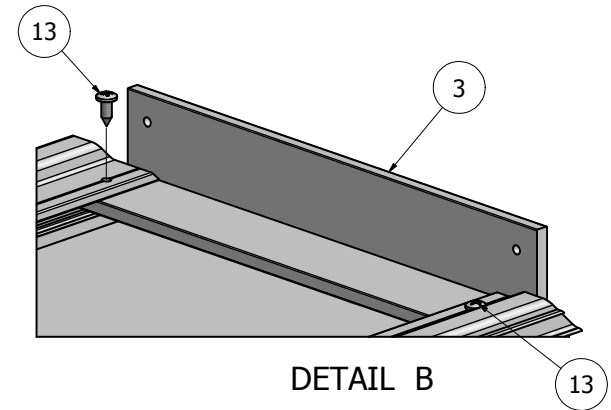

DETAIL B

NOTE: PRE-CUT KITS ARE NOT PRE-DRILLED.

(Holes shown in this drawing are for reference only.
Drilling of pilot holes are to be done by fabricator.)

THIS DRAWING WAS CREATED AT NO CHARGE TO ASSIST YOU IN VISUALIZING OUR PROPOSAL. THE DRAWING HEREIN IS THE PROPERTY OF SIGNCOMP. PERMISSION TO COPY OR REVISE THIS DRAWING OR TO USE THIS DRAWING FOR PRODUCTION IS STRICTLY PROHIBITED AND CAN ONLY BE COPIED, REVISED OR USED FOR PRODUCTION WITH THE EXPRESSED WRITTEN PERMISSION OF SIGNCOMP.

DRAWN	Sarah	3/5/2012	SignComp	
Centroid X:	0.000 in	TITLE		
Centroid Y:	0.000 in	Wide Body - Assembly		A
Principal Moments Ix:	0.000 in ⁴	DWG NO	K2005	REV
Principal Moments Iy:	0.000 in ⁴			
Section Modulus Ix:	0.000 in ³			
Section Modulus Iy:	0.000 in ³			

Parts List			
ITEM	PART #	DESCRIPTION	NOTES
1	2097	Large Inner Frame Retainer	Top & Bottom
2	2097	Large Inner Frame Retainer	Sides
3	5305	Frame Corner Angle	
4	5210	Corner Key	
30	5990	Inner/Outer Frame Corner Angle Screw	Drill #8 counter-sink

Ship To:
Order Number:

CORNER KEY HELPS
ALIGN THE MITRE
AND ADDS STRENGTH

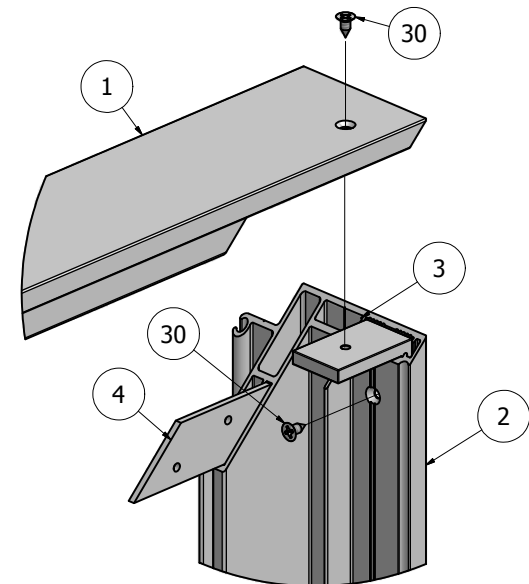
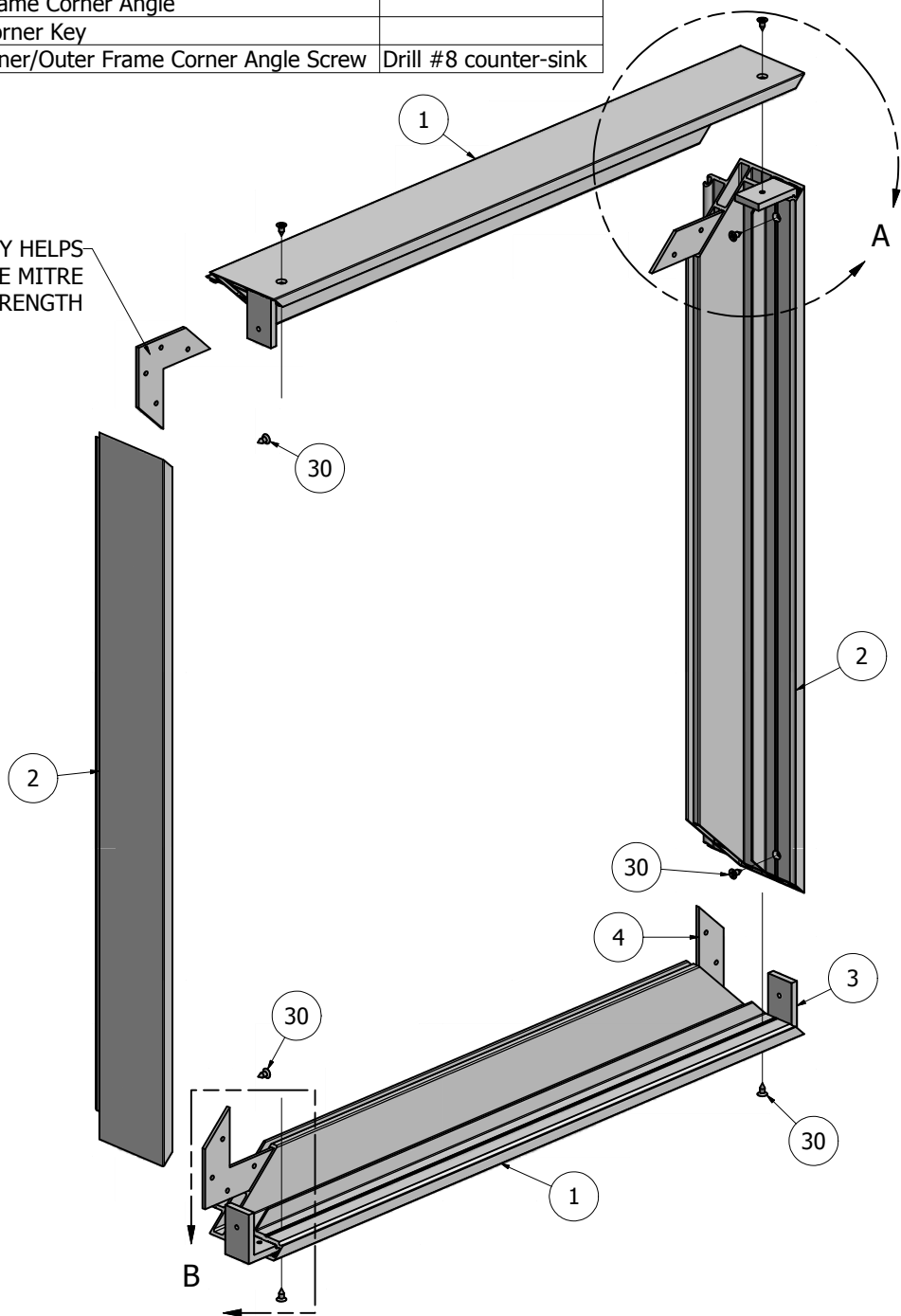

DETAIL A

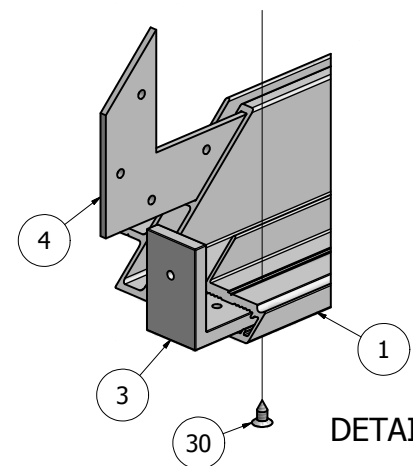

DETAIL B

NOTE: PRE-CUT KITS ARE NOT PRE-DRILLED.
(Holes shown in this drawing are for reference only.
Drilling of pilot holes are to be done by fabricator.)

THIS DRAWING WAS CREATED AT NO CHARGE TO ASSIST YOU IN VISUALIZING OUR PROPOSAL. THE DRAWING HEREIN IS THE PROPERTY OF SIGNCOMP. PERMISSION TO COPY OR REVISE THIS DRAWING OR TO USE THIS DRAWING FOR PRODUCTION IS STRICTLY PROHIBITED AND CAN ONLY BE COPIED, REVISED OR USED FOR PRODUCTION WITH THE EXPRESSED WRITTEN PERMISSION OF SIGNCOMP.

DRAWN	Sarah	3/7/2012
Centroid X:	0.000 in	
Centroid Y:	0.000 in	
Principal Moments Ix:	0.000 in ⁴	
Principal Moments Iy:	0.000 in ⁴	
Section Modulus Ix:	0.000 in ³	
Section Modulus Iy:	0.000 in ³	

SignComp

Large Inner Frame Retainer - Assembly

DWG NO	K2097	REV
--------	--------------	-----

Parts List			
ITEM	PART#	DESCRIPTION	NOTES
1	1941	2Part Large Outer Frame	Top & Bottom
2	1941	2Part Large Outer Frame	Sides
3	5305	Frame Corner Angle	
4	5210	Corner Key	
13	5218	Corner Angle Screw	Drill 5/32" pilot hole
30	5990	Inner/Outer Frame Corner Angle Screw	Drill #8 counter-sink

Ship To:
Order Number:

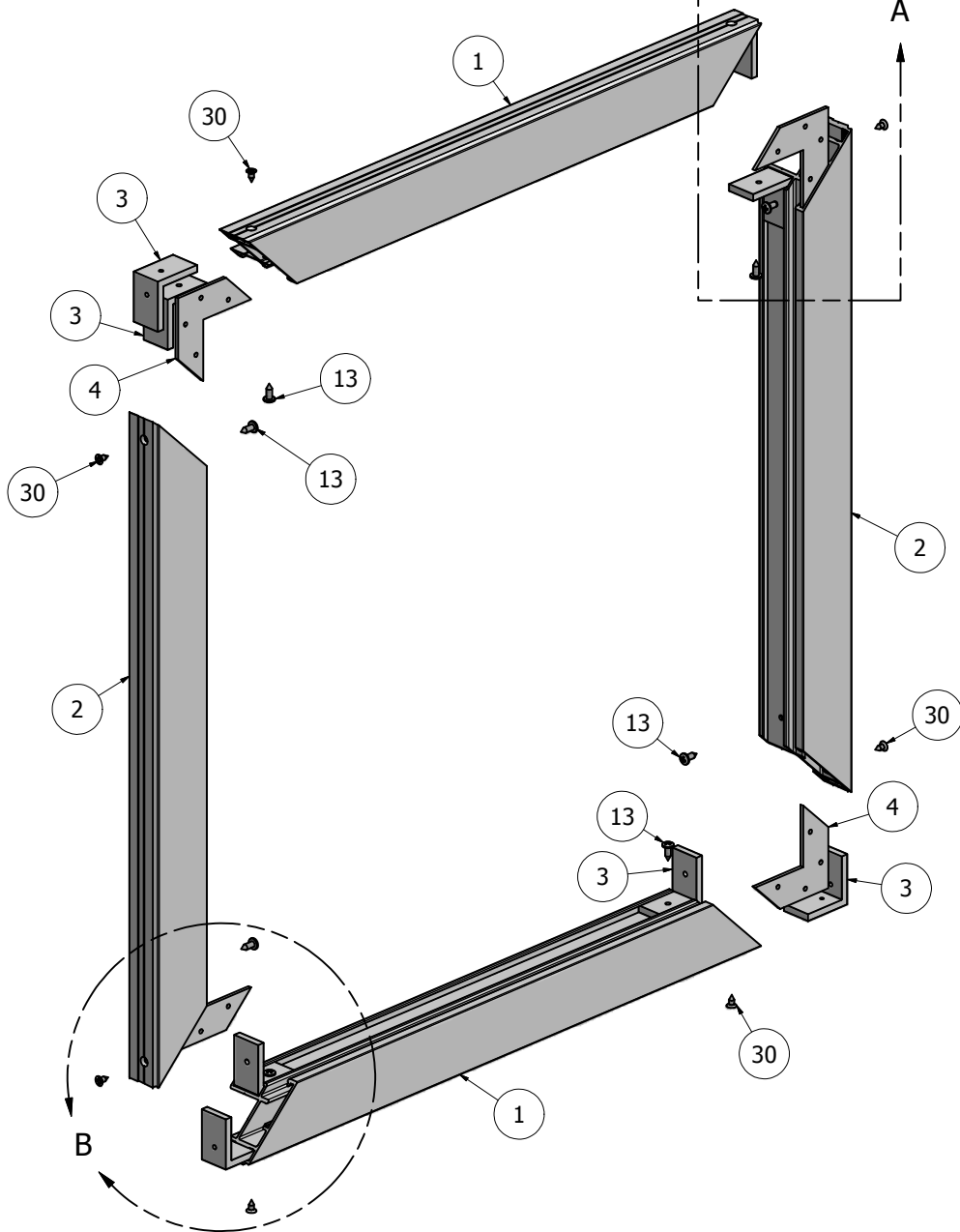

CORNER KEY HELPS
ALIGN THE MITRE
AND ADDS STRENGTH

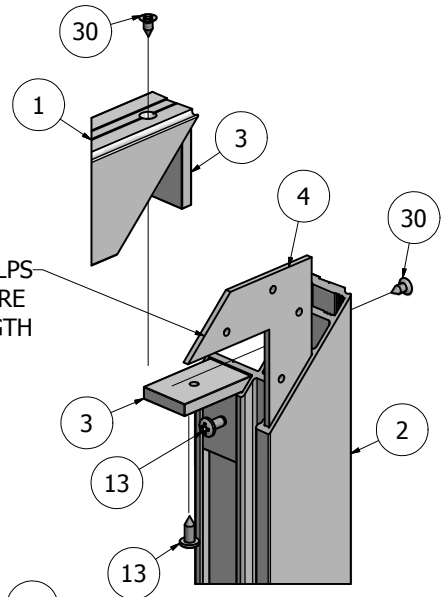

DETAIL A

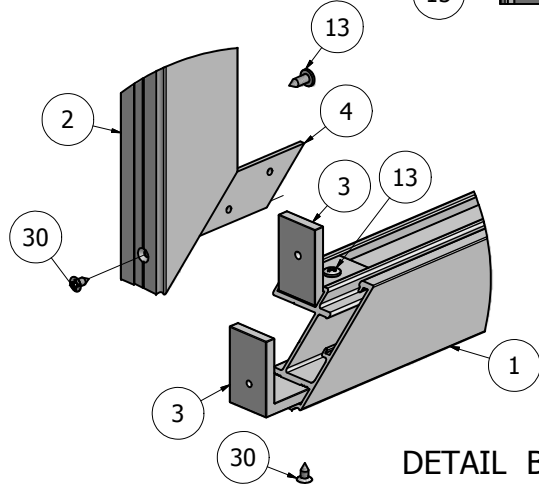

DETAIL B

NOTE: PRE-CUT KITS ARE NOT PRE-DRILLED.
(Holes shown in this drawing are for reference only.
Drilling of pilot holes are to be done by fabricator.)

THIS DRAWING WAS CREATED AT NO CHARGE TO ASSIST YOU IN VISUALIZING OUR PROPOSAL. THE DRAWING HEREIN IS THE PROPERTY OF SIGNCOMP. PERMISSION TO COPY OR REVISE THIS DRAWING OR TO USE THIS DRAWING FOR PRODUCTION IS STRICTLY PROHIBITED AND CAN ONLY BE COPIED, REVISED OR USED FOR PRODUCTION WITH THE EXPRESSED WRITTEN PERMISSION OF SIGNCOMP.

DRAWN	Sarah	3/7/2012	SignComp
Centroid X:	0.000 in		
Centroid Y:	0.000 in		TITLE
Principal Moments Ix:	0.000 in ⁴		2Part Large Outer Frame - Assembly
Principal Moments Iy:	0.000 in ⁴		DWG NO
Section Modulus Ix:	0.000 in ³		K1941
Section Modulus Iy:	0.000 in ³		REV
			SHEET 1 OF 1

Parts List			
ITEM	PART#	DESCRIPTION	Notes
1	1941	2Part Large Outer Frame	
2		Hinge Fastener	1/8" Pop Rivet or #8 Counter Sink Screw
3	5997	2Part Large Hinge	
4	5993	2Part Large Lock	Drill 3/4" Hole - See Detail "A"
5		Large Lock Nut	
6		Lock Spacer	
7		Large Cam	
8		Sprong Washer	
9		Lock Screw	

Ship To:
Order Number:

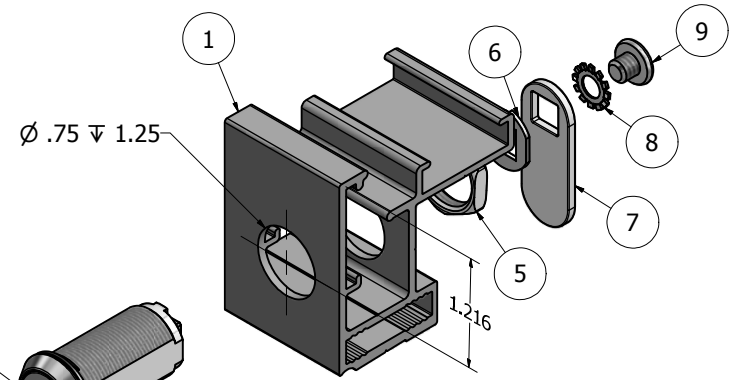

DETAIL A-1

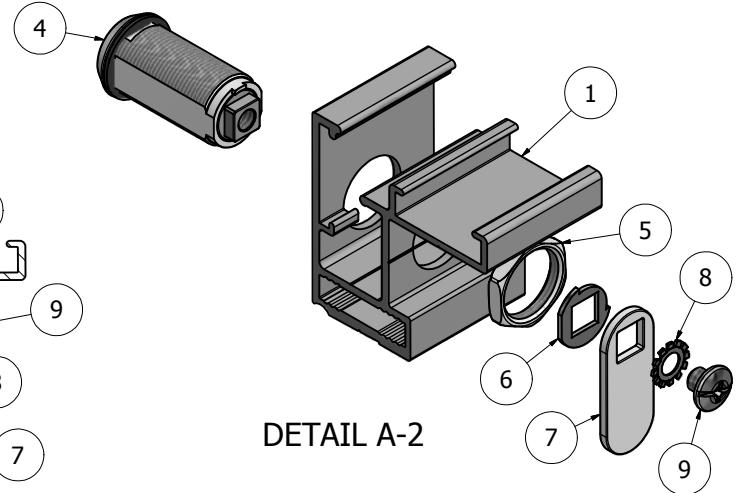

DETAIL A-2

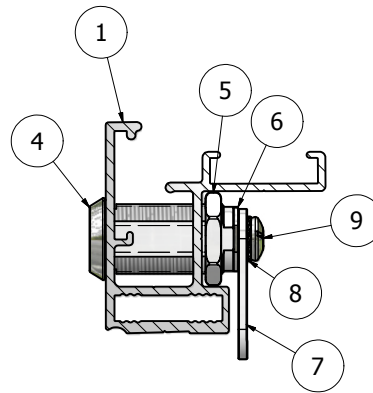

DETAIL B

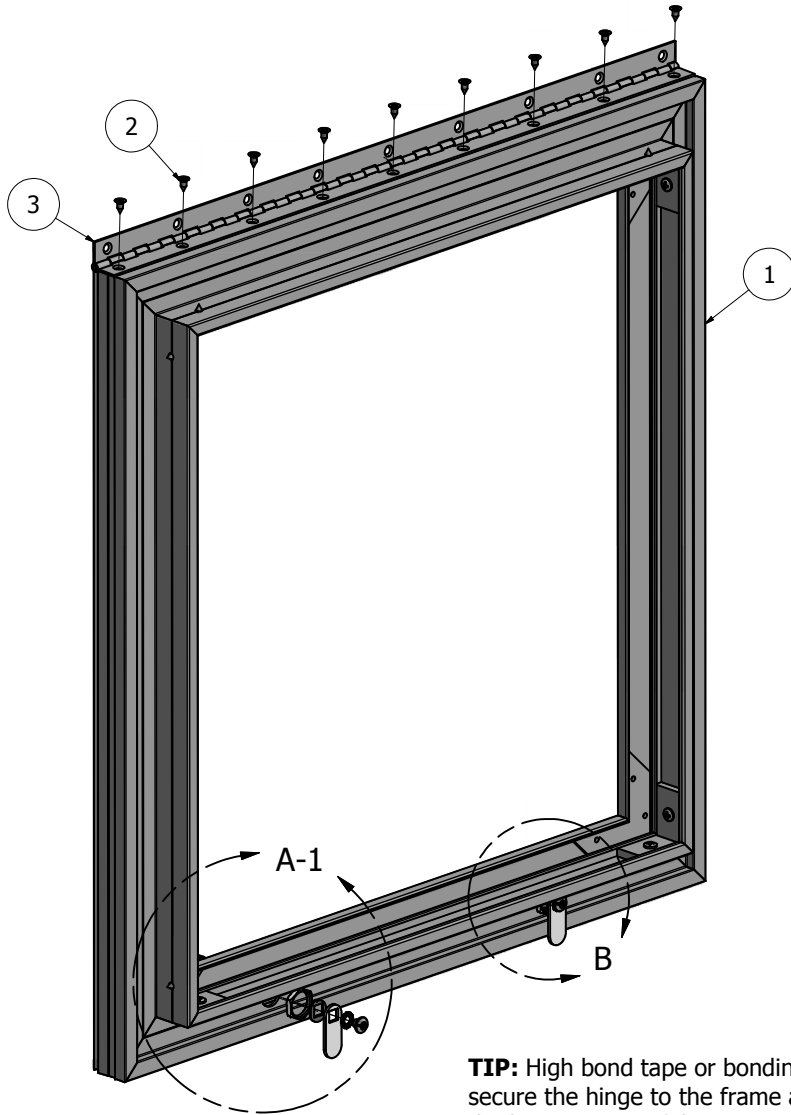

TIP: High bond tape or bonding agents can be used to help secure the hinge to the frame and assist in the installation of the hinge. Be careful not to get the tape on the barrel of the hinge. To do so may cause the hinge not to open properly.

NOTE: PRE-CUT KITS ARE NOT PRE-DRILLED.
(Holes shown in this drawing are for reference only.
Drilling of pilot holes are to be done by fabricator.)

THIS DRAWING WAS CREATED AT NO CHARGE TO ASSIST YOU IN VISUALIZING OUR PROPOSAL. THE DRAWING HEREIN IS THE PROPERTY OF SIGNCOMP. PERMISSION TO COPY OR REVISE THIS DRAWING OR TO USE THIS DRAWING FOR PRODUCTION IS STRICTLY PROHIBITED AND CAN ONLY BE COPIED, REVISED OR USED FOR PRODUCTION WITH THE EXPRESSED WRITTEN PERMISSION OF SIGNCOMP.

DRAWN	Sarah	3/19/2012	SignComp
Centroid X:	0.000 in	TITLE	
Centroid Y:	0.000 in	2Part Outer Frame - 2Part Hinge - 2Part Lock - Assembly	
Principal Moments Ix:	0.000 in ⁴	DWG NO	REV
Principal Moments Iy:	0.000 in ⁴	K1941-5993-97	
Section Modulus Ix:	0.000 in ³	SHEET 1 OF 1	
Section Modulus Iy:	0.000 in ³		

Parts List			
ITEM	PART#	DESCRIPTION	NOTES
1	K2097	Large Inner Frame Retainer	Assembly
2	K1941	2Part Outer Frame	Assembly
31	5990	2Part Large / Small Hinge Screw	1/8" Pop Rivetor #8 Counter Sink Fastener

Ship To:
Order Number:

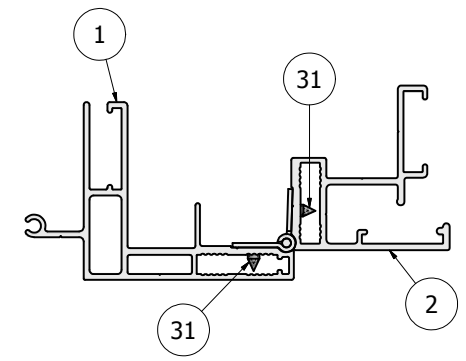
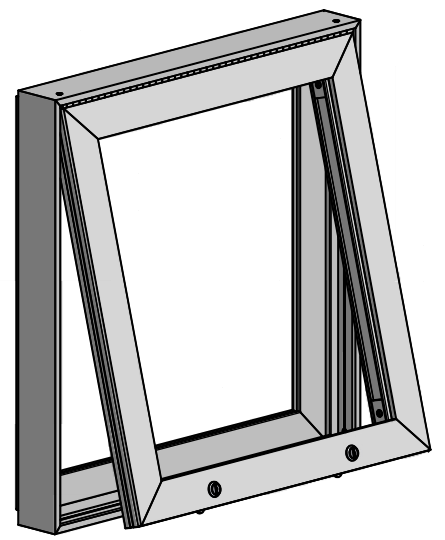
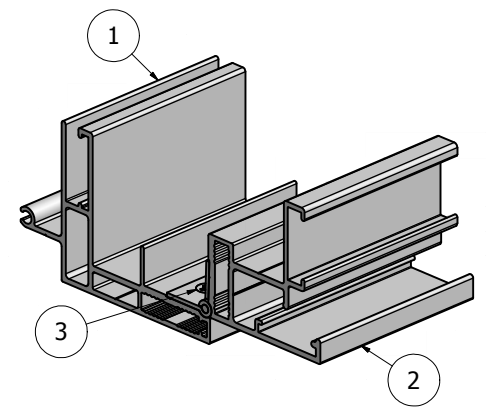
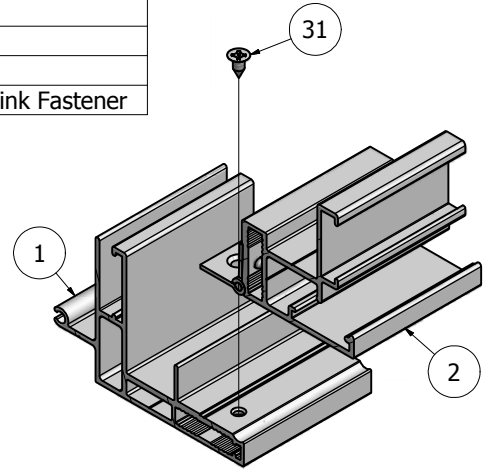
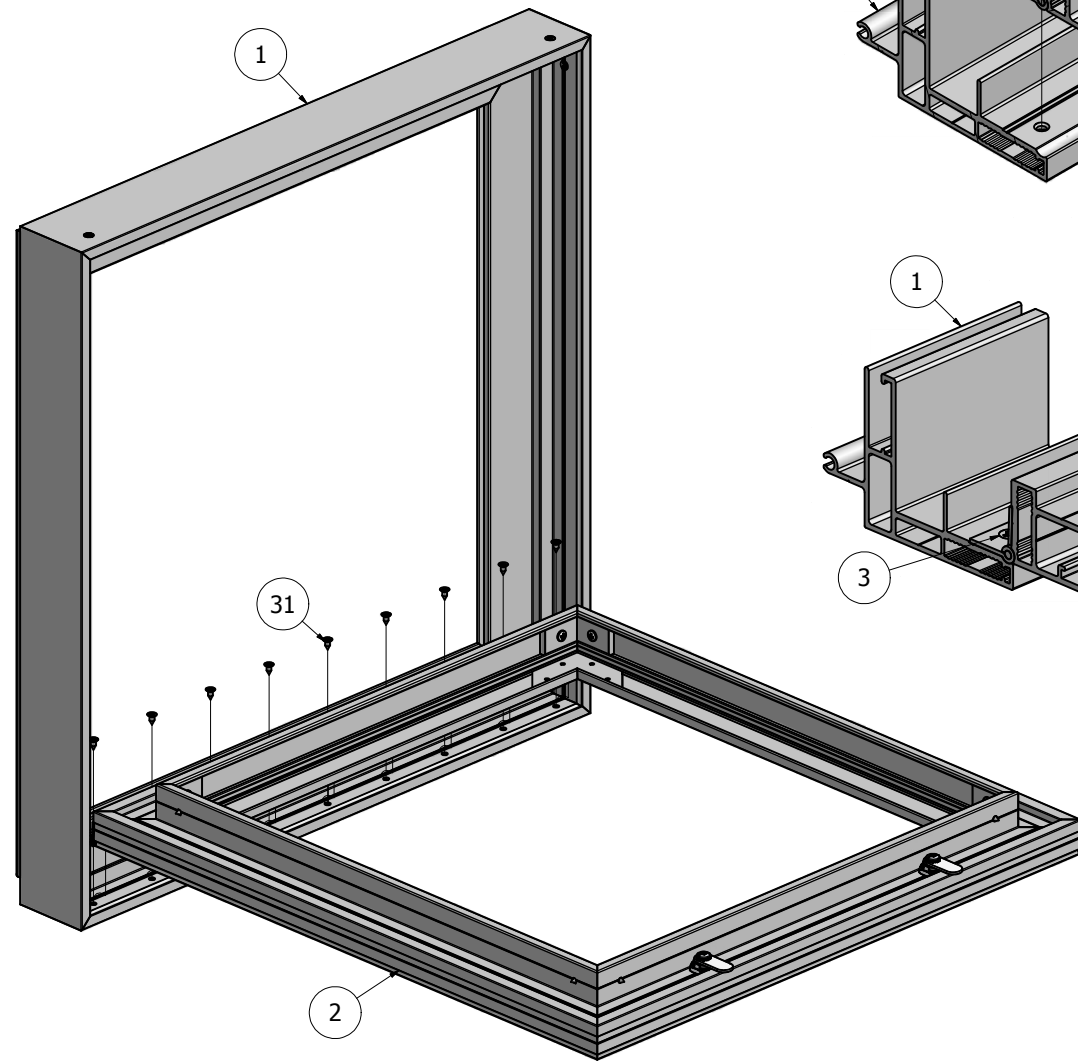

NOTE: PRE-CUT KITS ARE NOT PRE-DRILLED.
(Holes shown in this drawing are for reference only.
Drilling of pilot holes are to be done by fabricator.)

THIS DRAWING WAS CREATED AT NO CHARGE TO ASSIST YOU IN VISUALIZING OUR PROPOSAL. THE DRAWING HEREIN IS THE PROPERTY OF SIGNCOMP. PERMISSION TO COPY OR REVISE THIS DRAWING OR TO USE THIS DRAWING FOR PRODUCTION IS STRICTLY PROHIBITED AND CAN ONLY BE COPIED, REVISED OR USED FOR PRODUCTION WITH THE EXPRESSED WRITTEN PERMISSION OF SIGNCOMP.		
DRAWN	Sarah	4/30/2012
Centroid X:	0.000 in	
Centroid Y:	0.000 in	
Principal Moments Ix:	0.000 in ⁴	
Principal Moments Iy:	0.000 in ⁴	
Section Modulus Ix:	0.000 in ³	
Section Modulus Iy:	0.000 in ³	
<h1 style="text-align: center;">SignComp</h1>		TITLE
		<h2 style="text-align: center;">Large Inner Frame Retainer and 2Part Outer Frame - Assembly</h2>
DWG NO		REV
K2097-1941		
SHEET 1 OF 1		

TIP: High bond tape or bonding agents can be used to help secure the hinge to the frame and assist in the installation of the hinge. Be careful not to get the tape on the barrel of the hinge. Doing so may cause the hinge not to open properly.