

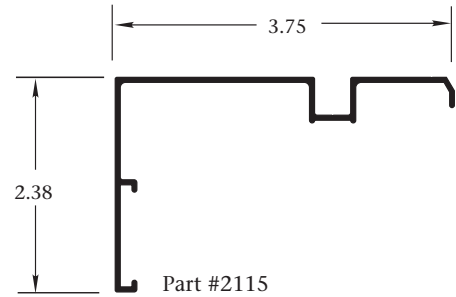

2" Retro Frame with Cover

Part Number	Part	Length	Finish
2112	2" Retro Frame	24'-5"	Mill Finish
2115	2-3/8" Retro Frame Cover	24'-5"	Mill Finish

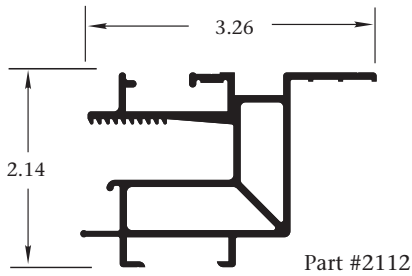

Features & Benefits

- Retro fits to new or existing cabinets
 - Easily assembles with structural corner angles
 - Designed to accept optional frame support
 - Easily accommodates the Dual Divider and Cover
- Part #'s 2142 and 2146

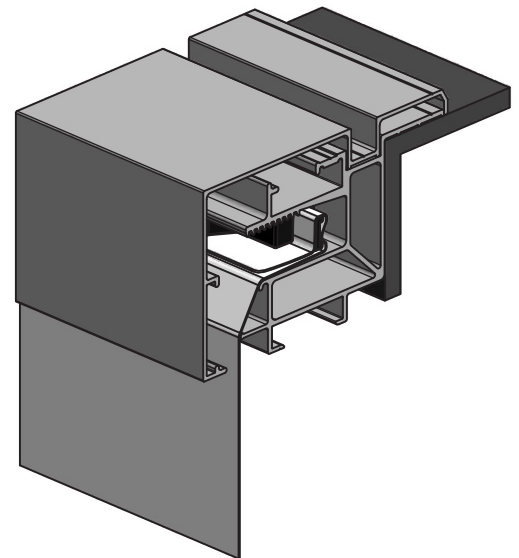
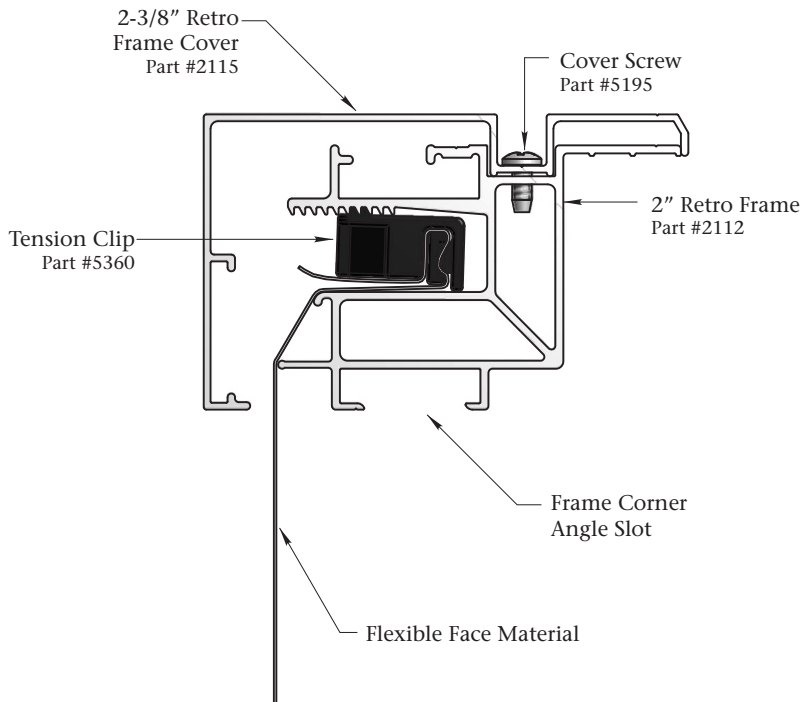

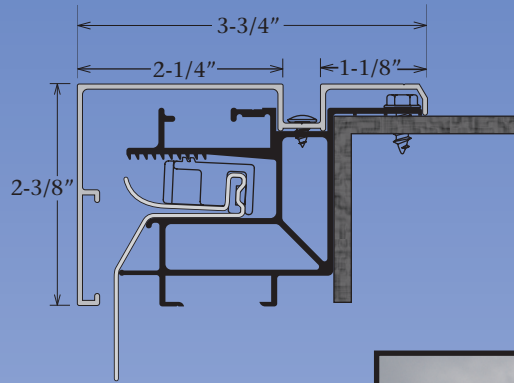

See page 13, 15 & 37 in the Gold Commercial Catalog for more details.

Features & Benefits

The 2" Retro Frame is designed to fit over an existing sign or support structure. It will tension any size flexible face or banner material. The Tension Clips are easy to use and are re-useable. Eliminates hemming, grommets and double faced tape. The Dual Divider & Cover can be used to divide the flexible face into panels or transition from a flexible face to a rigid face.



Answers to FAQ's

- Accepts any flexible face material.
- Face material trim size - Add 1-1/2" of fabric to all four sides. (Adding a total of 3" to both the height and width)
- Tension Clip placement - Tension Clips are placed approximately 1-1/2" from the edge of the trimmed to size face material.
- Tension Clip spacing - Every 6" on center.
- The correct Tension Tool to use with the frame is Part # 5135.
- Frame Support Tube and Frame Brace assemblies may be required if the existing sign or sub-structure is not structural enough to support the tension and wind loads.

