

STD-10 for Rigid Faces - Electrical

2Part 12" Double Face Body
Part #1929

2Part Large Inner Frame
Part #1959

2Part Large Outer Frame
Part #1941

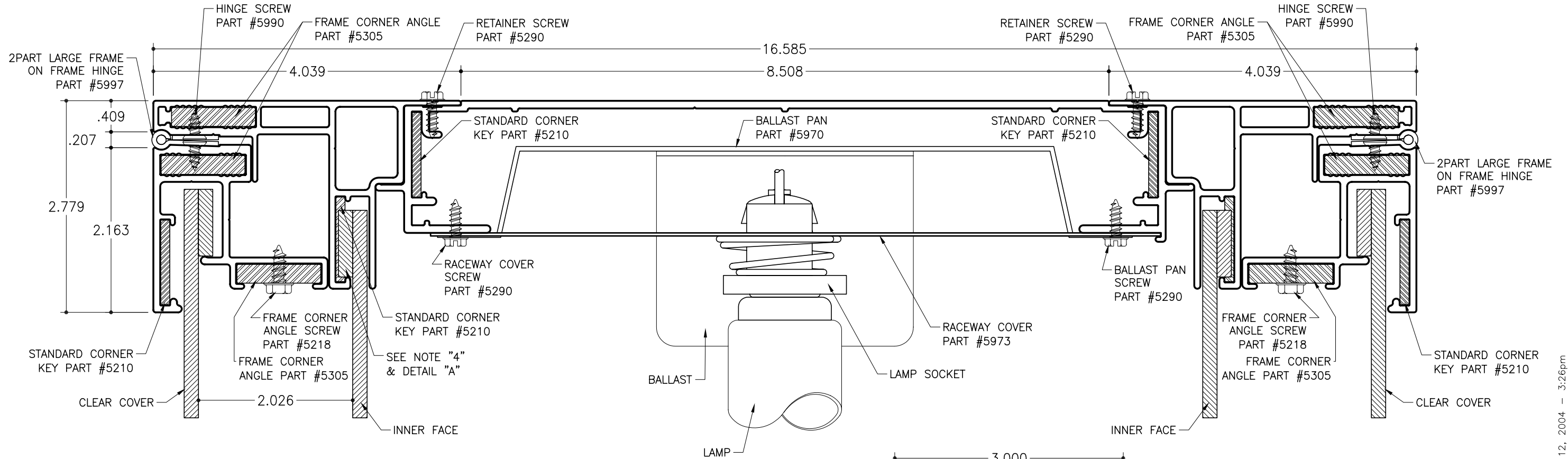

SECTION DETAIL - ELECTRICAL

SCALE : 3/4" = 1"

NOTES:

1. Add 1 1/2" to 1 3/4" to the overall width or height of cabinet depending on which direction the lamps will be placed. (vertical or horizontal)
2. SignComp does not supply the ballast(s), lamps or lamp sockets.
3. 2Part Large Outer Frame to be cut 1 3/16" less than the overall width and 1 3/8" less than the overall height.
4. Inner face hanging bar to be placed 3" in from edges of inner face, this will allow the hanging bar to clear the corner keys. The hanging bar is to be attached to the face side of the inner face.
5. Hinge screws are to be 3" on center the first 16" in from each end the remainder 8"-10" apart.

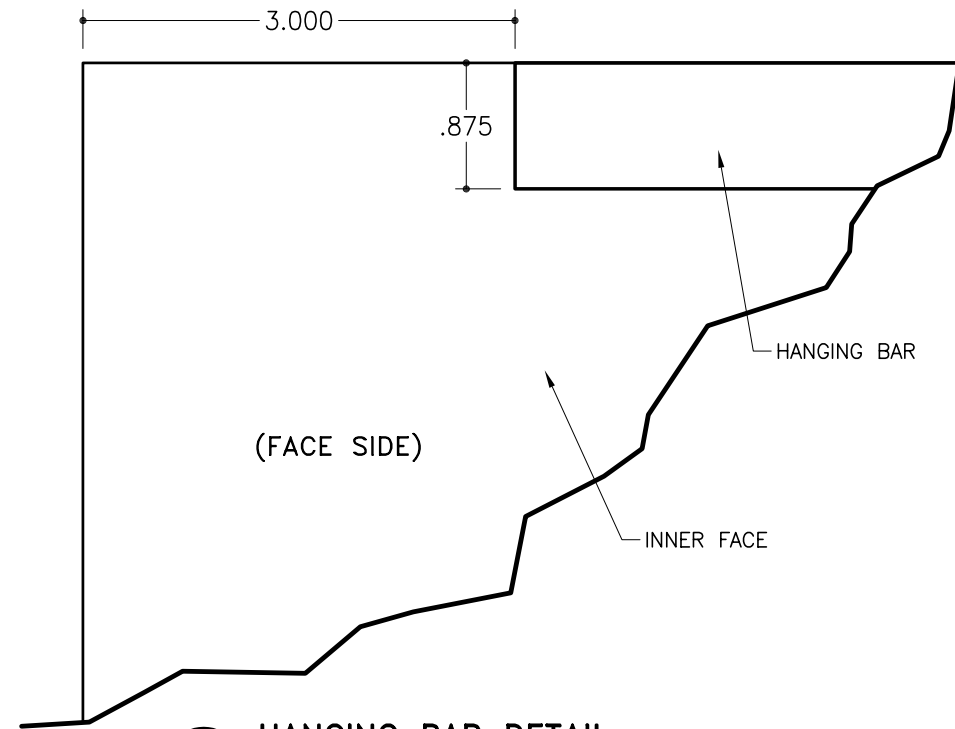

A HANGING BAR DETAIL

SCALE : 3/4" = 1"

STD-10 for Rigid Faces - Structural Corner

2Part 12" Double Face Body
Part #1929

2Part Large Inner Frame
Part #1959

2Part Large Outer Frame
Part #1941

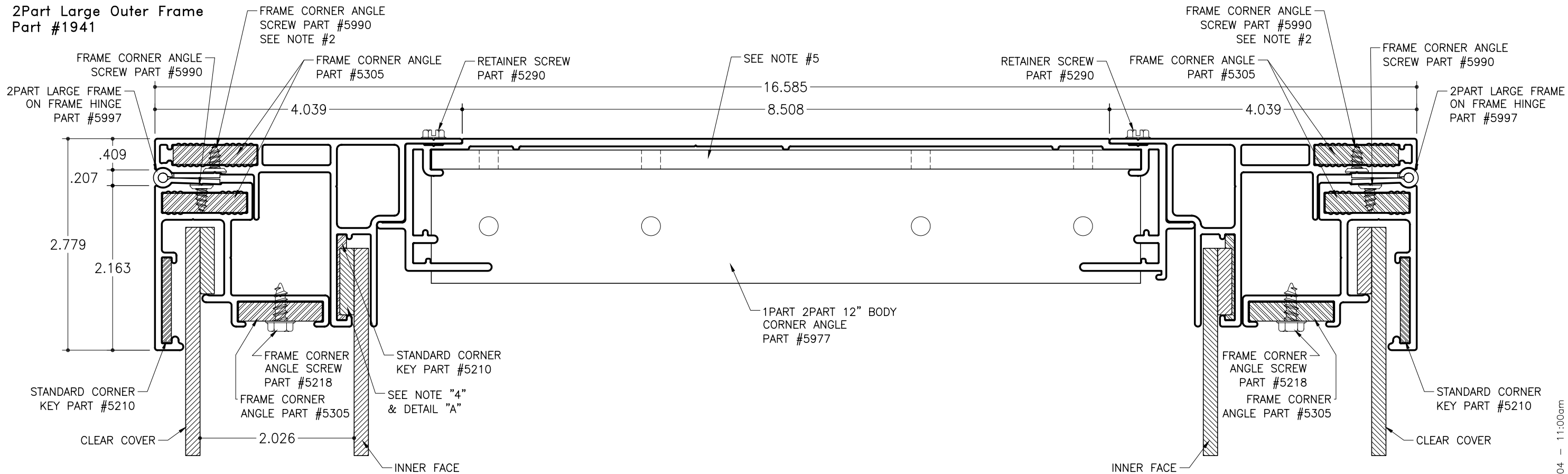

SECTION DETAIL STRUCTURAL (BODY CORNER ANGLE W/ADHESIVE BOND)

SCALE : 3/4" = 1"

NOTES:

1. Add 1 1/2" to 1 3/4" to the overall width or height of cabinet depending on which direction the lamps will be placed. (vertical or horizontal)
2. Corner angles can be secured by mechanically fastening or by using adhesive. NOTE: If corner angles are attached with adhesive it is recommended that one or both of the vertical frames are made to be removable for servicing. The corner angles that are to be attached with adhesive need to be located in the vertical frame and the opposite adjacent corner are mechanically fastened.
3. 2Part Large Outer Frame to be cut 1 3/16" less than the overall width and 1 3/8" less than the overall height.
4. Inner face hanging bar to be placed 3" in from edges of inner face, this will allow the hanging bar to clear the corner keys. The hanging bar is to be attached to the face side of the inner face. (SEE DETAIL "A")
5. Holes located in corner angles are adhesive injection points.

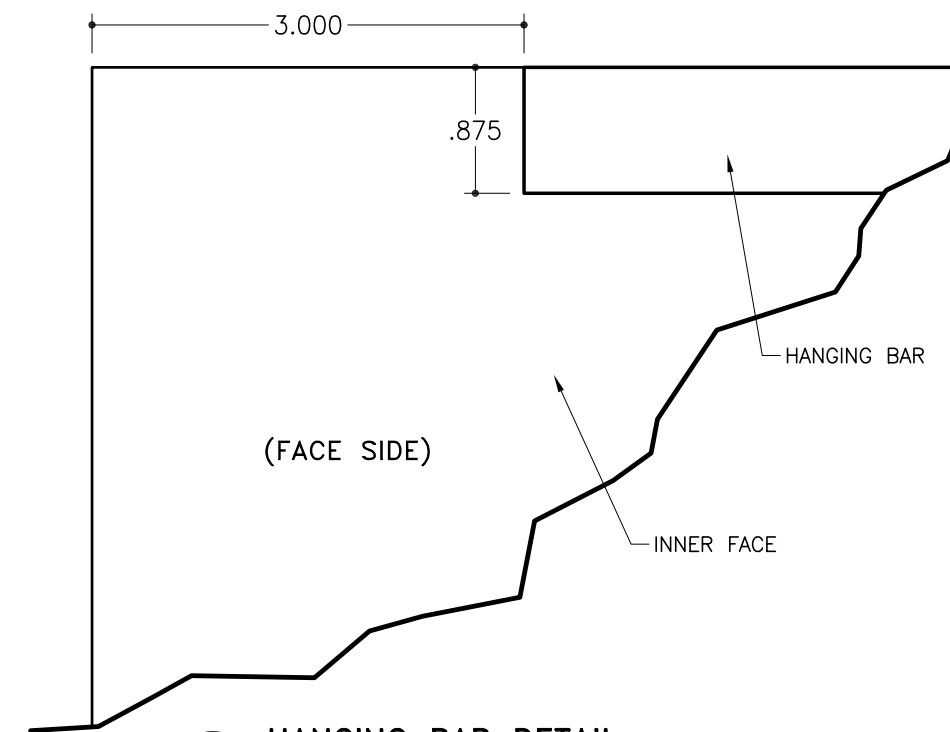

A HANGING BAR DETAIL
SCALE : 3/4" = 1"

STD-10 for Rigid Faces - Structural Corner

2Part 12" Double Face Body
 Part #1929

2Part Large Inner Frame
 Part #1959

2Part Large Outer Frame
 Part #1941

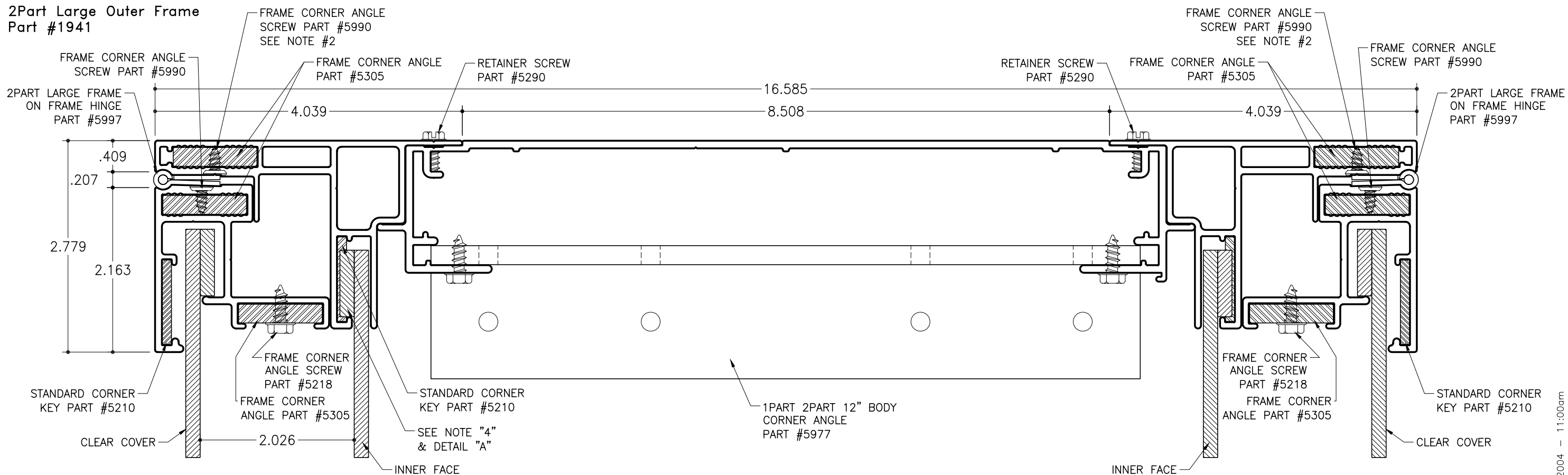

SECTION DETAIL STRUCTURAL (BODY CORNER ANGLE MECHANICALLY FASTENED)

SCALE : 3/4" = 1"

NOTES:

1. Add 1 1/2" to 1 3/4" to the overall width or height of cabinet depending on which direction the lamps will be placed. (vertical or horizontal)
2. Corner angles can be secured by mechanically fastening or by using adhesive. NOTE: If corner angles are attached with adhesive it is recommended that one or both of the vertical frames are made to be removable for servicing. The corner angles that are to be attached with adhesive need to be located in the vertical frame and the opposite adjacent corner are mechanically fastened.
3. 2Part Large Outer Frame to be cut 1 3/16" less than the overall width and 1 3/8" less than the overall height.
4. Inner face hanging bar to be placed 3" in from edges of inner face, this will allow the hanging bar to clear the corner keys. The hanging bar is to be attached to the face side of the inner face.

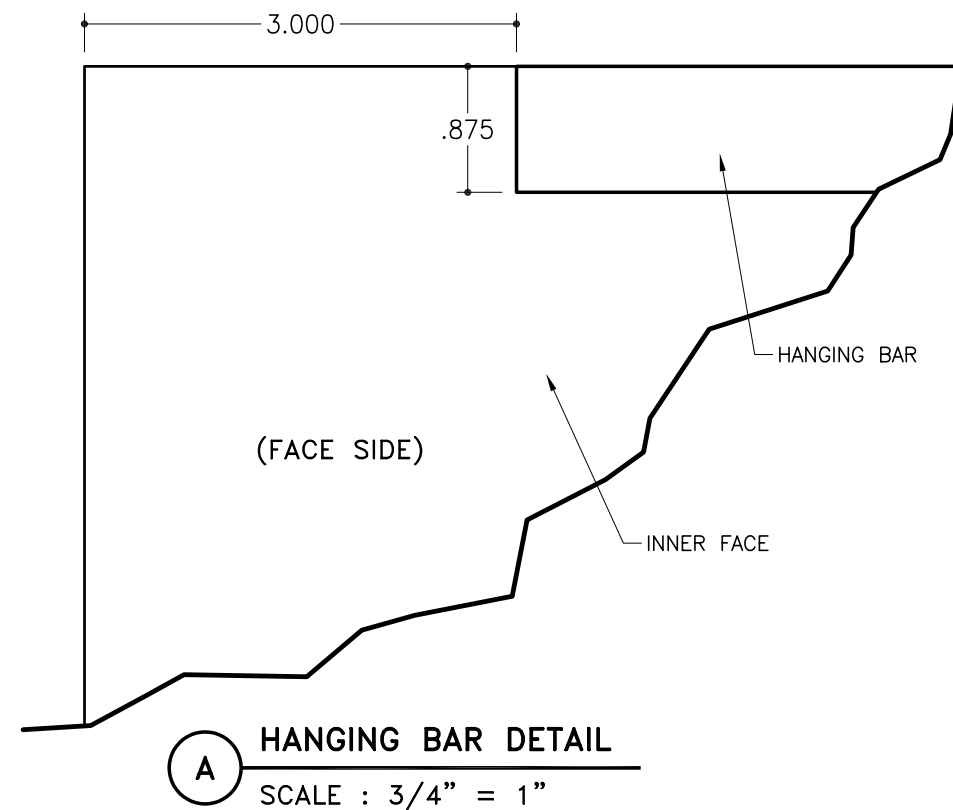

HANGING BAR DETAIL

SCALE : 3/4" = 1"

STD-10 for Rigid Faces - Structural Corner

2Part 12" Double Face Body
 Part #1929

2Part Large Inner Frame
 Part #1959

2Part Large Outer Frame
 Part #1941

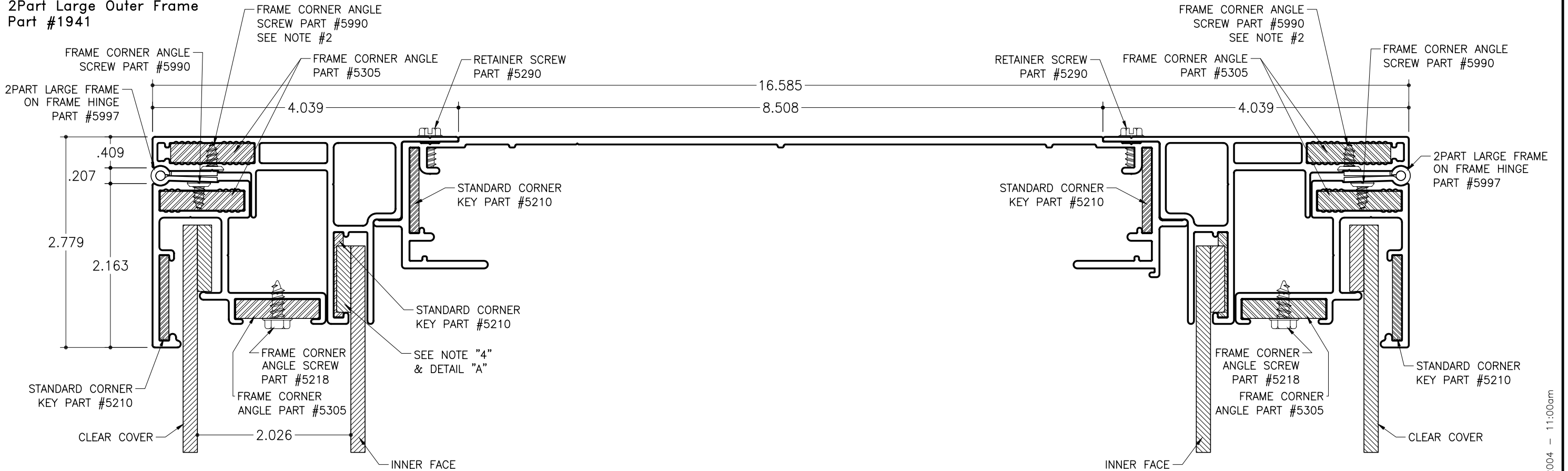

SECTION DETAIL STRUCTURAL (WELDED W/CORNER KEYS)

SCALE : 3/4" = 1"

NOTES:

1. Add 1/2" to 3/4" to the overall width or height of cabinet depending on which direction the lamps will be placed. (vertical or horizontal)
2. Corner angles can be secured by mechanically fastening or by using adhesive. NOTE: If corner angles are attached with adhesive it is recommended that one or both of the vertical frames are made to be removable for servicing. The corner angles that are to be attached with adhesive need to be located in the vertical frame and the opposite adjacent corner are mechanically fastened.
3. 2Part Large Outer Frame to be cut 3/16" less than the overall width and 3/8" less than the overall height.
4. Inner face hanging bar to be placed 3" in from edges of inner face, this will allow the hanging bar to clear the corner keys. The hanging bar is to be attached to the face side of the inner face.

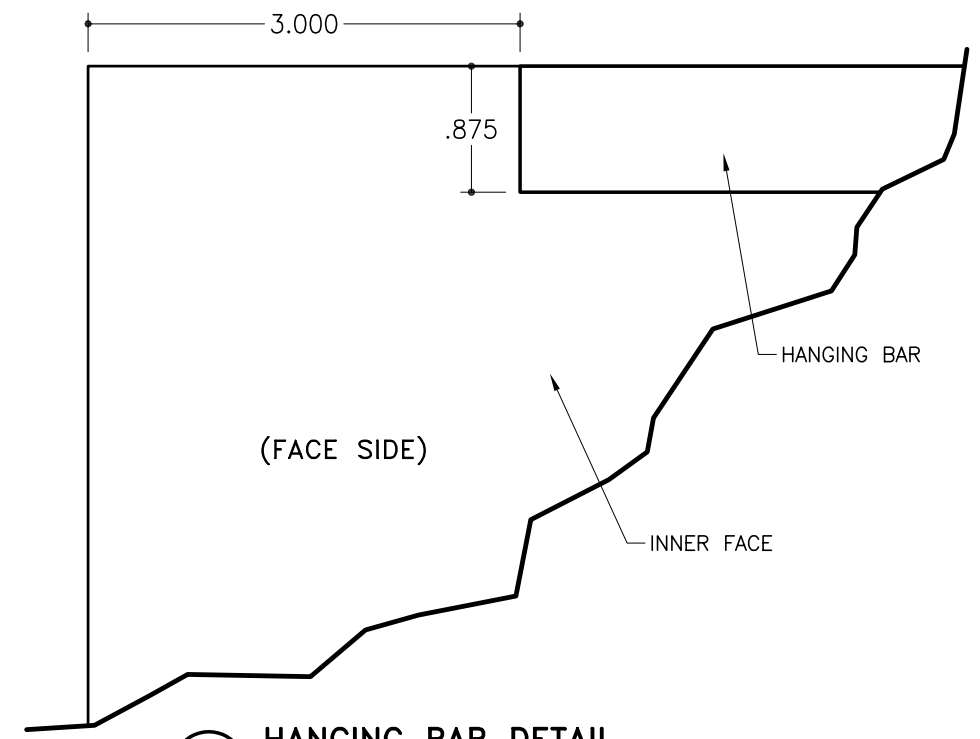

A HANGING BAR DETAIL
 SCALE : 3/4" = 1"

STD-10 for Rigid Faces – Structural Corner

- 2Part 12" Double Face Body
Part #1929
- 2Part Large Inner Frame
Part #1959
- 2Part Large Outer Frame
Part #1941

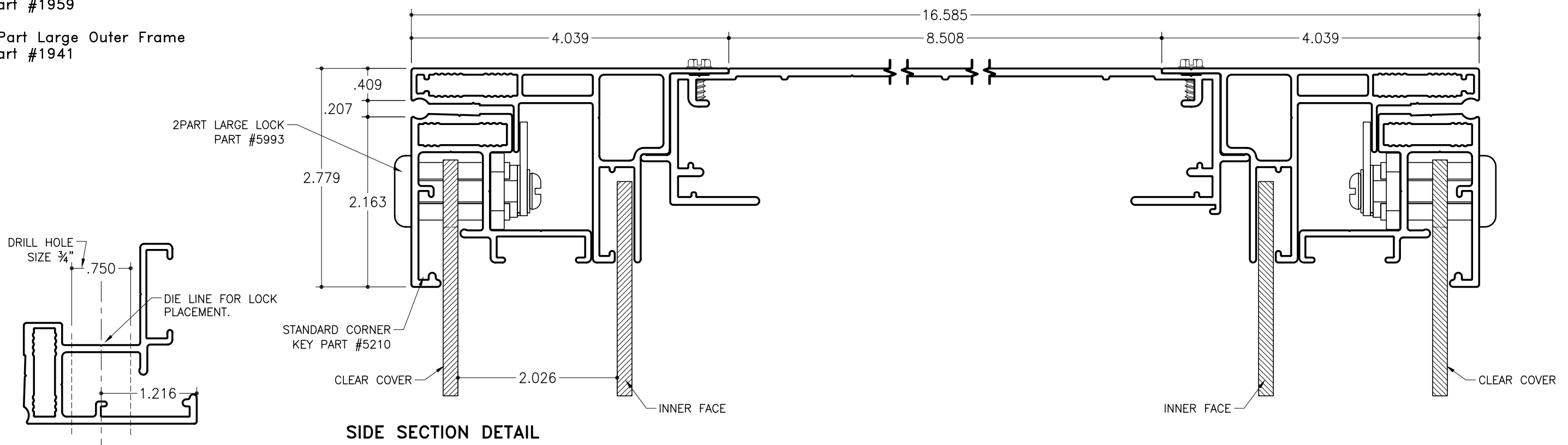

SIDE SECTION DETAIL

SCALE : 3/4" = 1"

LOCK HOLE DETAIL

SCALE : 3/4" = 1"

- NOTES:
1. Notch face to fit around lock leaving 1/8" of space around lock for proper expansion and contraction of face.
 2. DO NOT OVER TIGHTEN LOCK NUT. Over tightening lock nut will cause the space allowed for the face to sit too close down and the face not to slide into the channel.
 3. Apply "lock tight" to lock nut. Apply nut to lock and snug down.
 4. Locks can be placed on the side or bottom frame(s), As a guide line for placement of the locks times the height in feet or the width in feet by 3. This will give you the distance in inches where the locks can be placed on the 2Part Large Outer Frame.

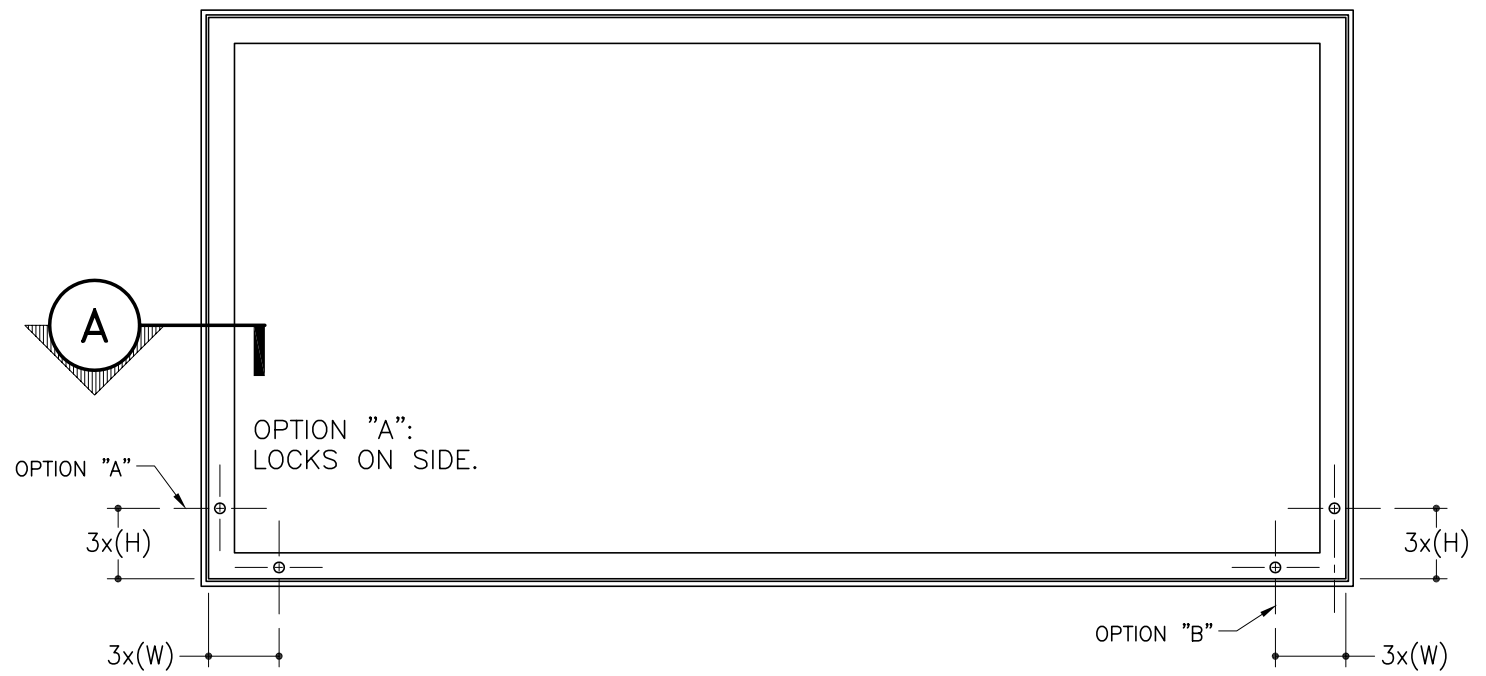

LOCK PLACEMENT

SCALE : 3/4" = 1"

STD-10 for Rigid Faces – Structural Corner

- 2Part 12" Double Face Body
Part #1929
- 2Part Large Inner Frame
Part #1959
- 2Part Large Outer Frame
Part #1941

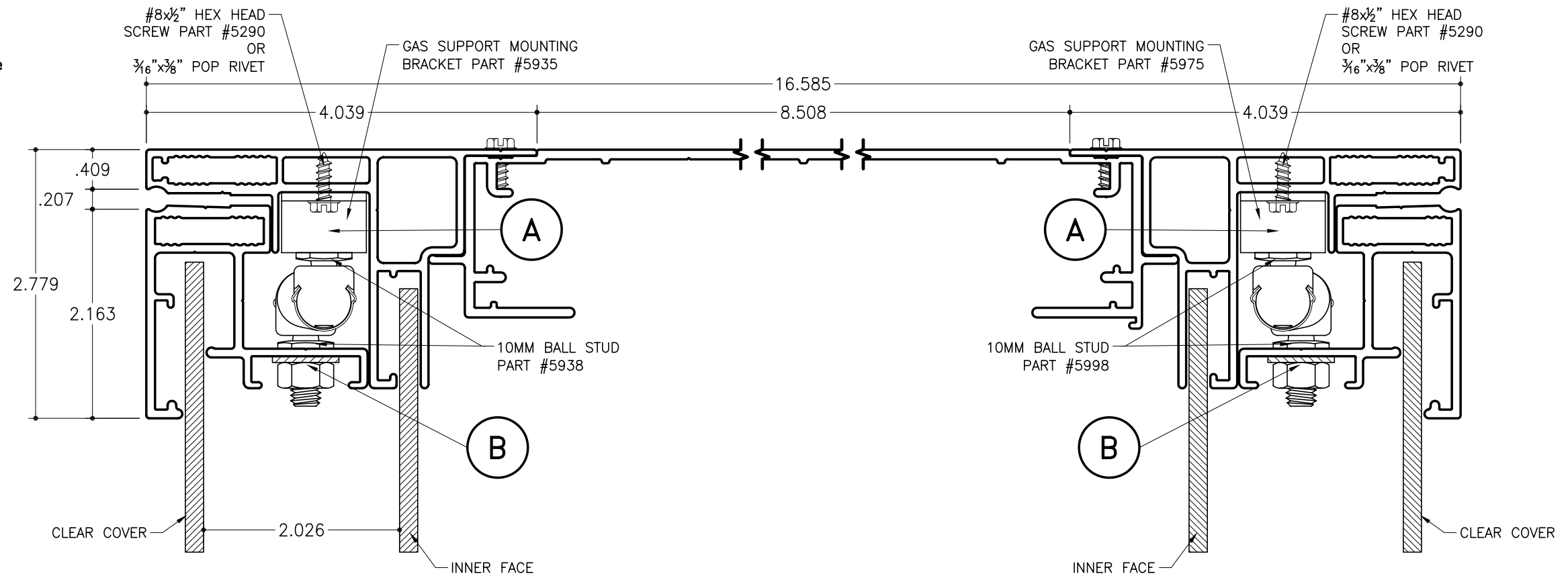

SIDE SECTION DETAIL
 SCALE : 3/4" = 1"

NOTES:

1. Upper attachment point is located on 2Part Large Inner Frame. To find the location of the attachment point divide the overall height by 3.
2. Lower attachment point is located on 2Part Large Outer Frame. To find the location use the compressed length of the gas support.
3. Install on ball studs as shown right (Gas Support Open). Fig. A

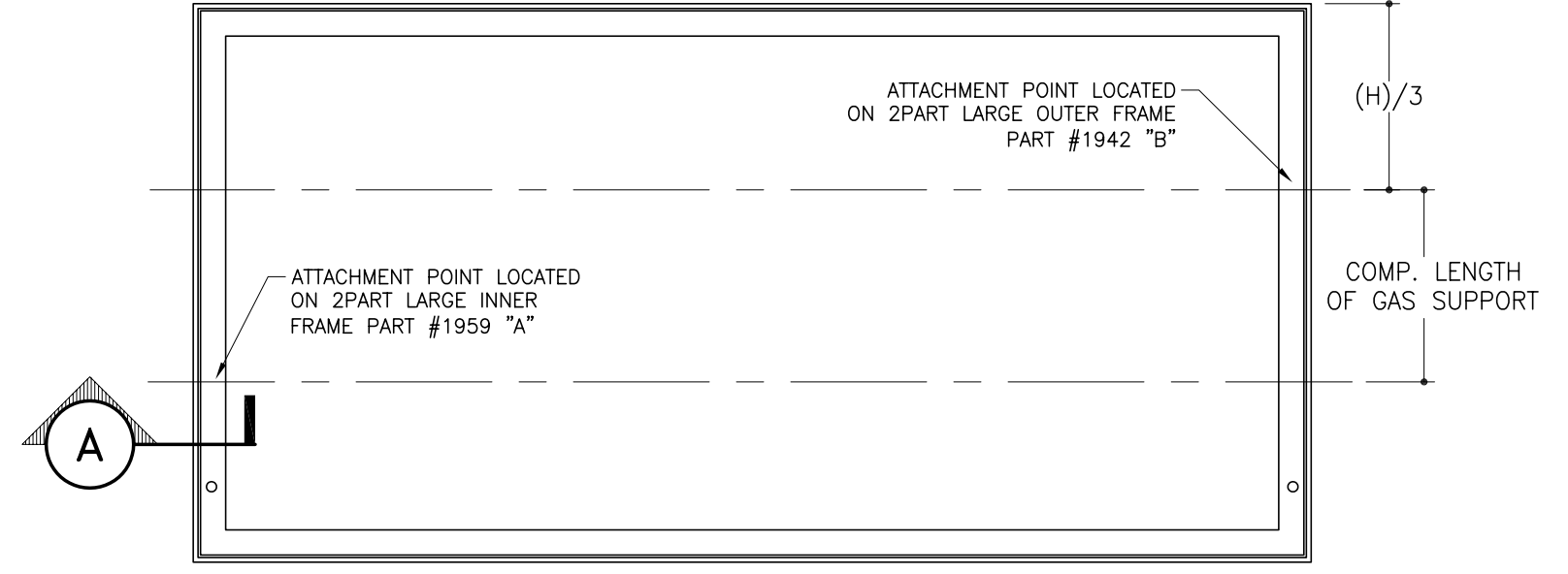
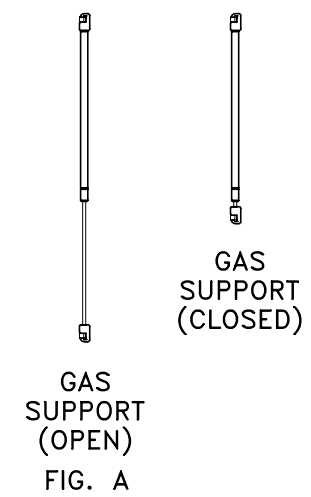

GAS SUPPORT PLACEMENT
 SCALE : 3/4" = 1"

- COMPRESSED LENGTH OF SUPPORTS:
- PART #5930 = 8.75"
 - PART #5932 = 10.50"
 - PART #5934 = 16.25"

STD-10 for Rigid Faces - Gas Supports

2Part 12" Body
Part #1929

2Part Large Inner Frame
Part #1959

2Part Large Outer Frame

SEE ATTACHMENT POINT "B"
ON SHEET 6 OF 7

SEE ATTACHMENT POINT "A"
ON SHEET 6 OF 7

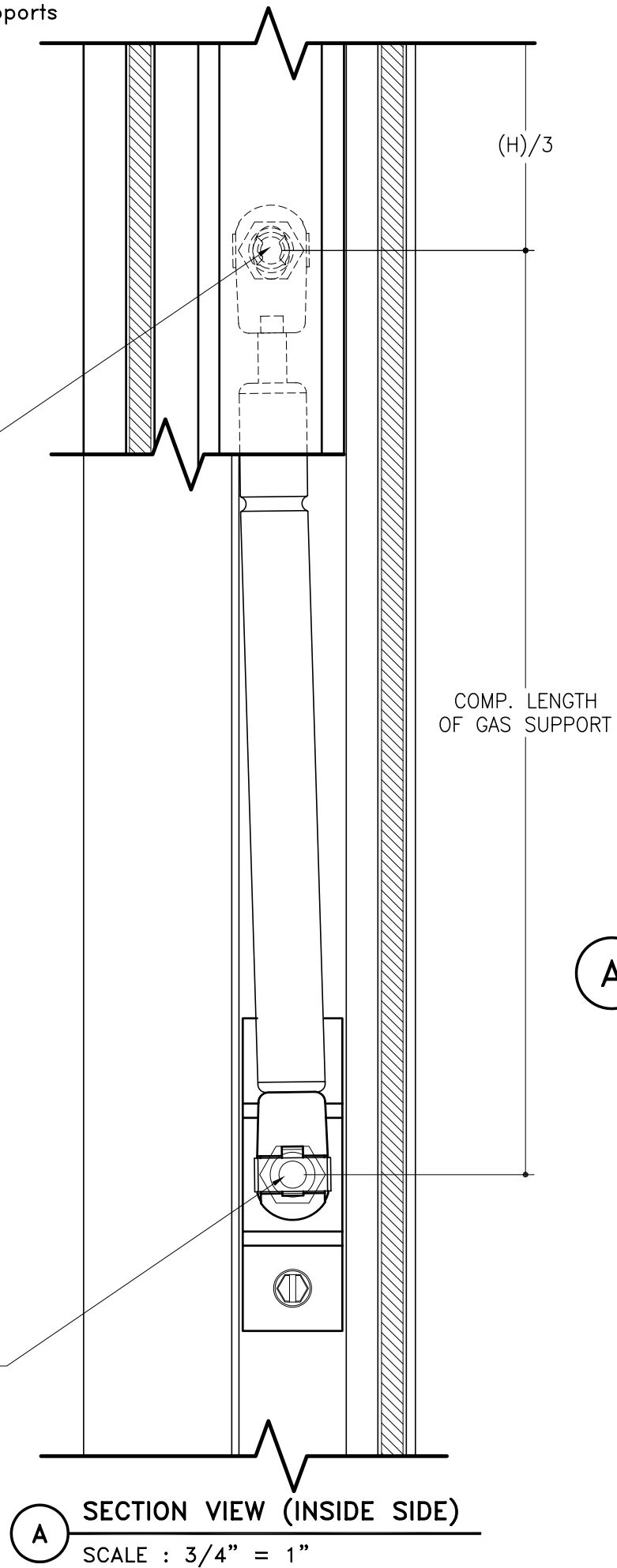

A SECTION VIEW (INSIDE SIDE)
SCALE : 3/4" = 1"

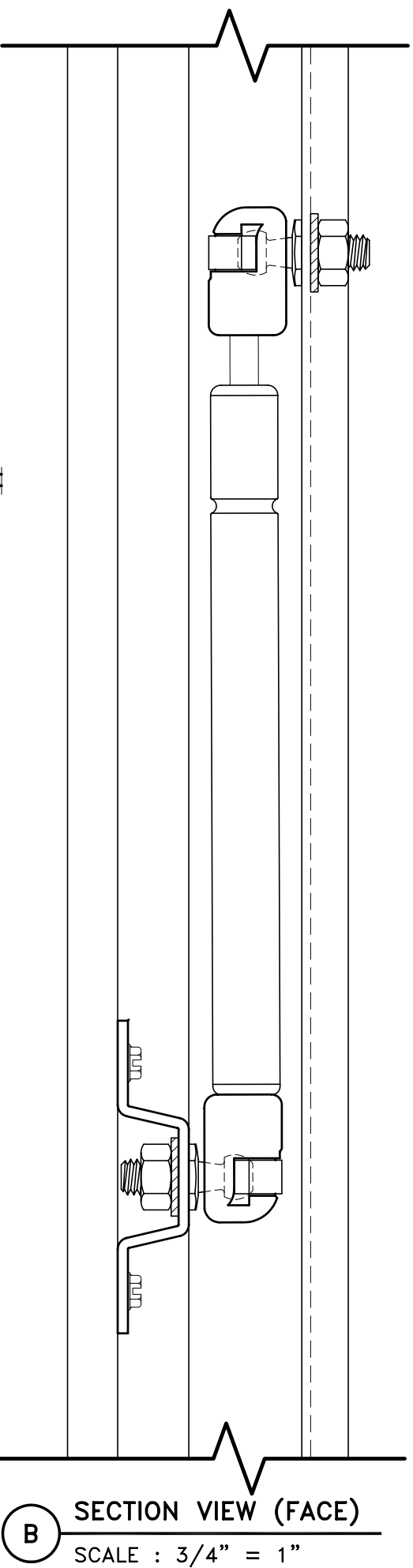
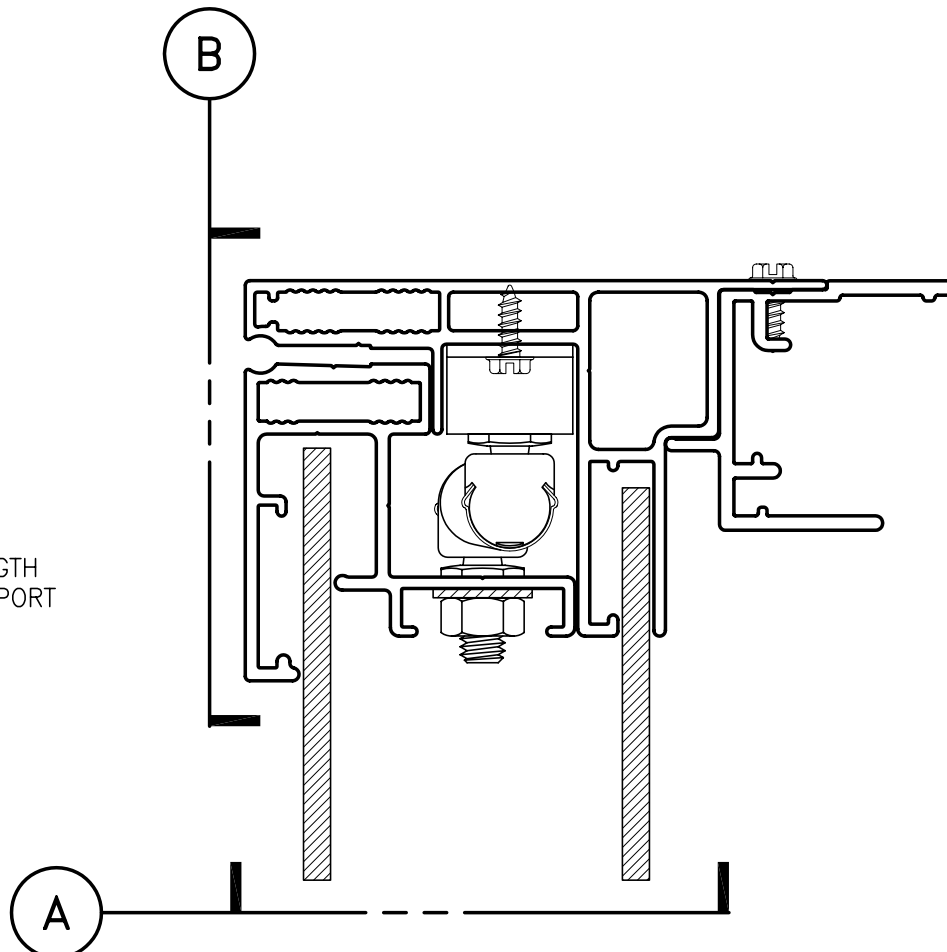

B SECTION VIEW (FACE)
SCALE : 3/4" = 1"