

STD-12 for Rigid Faces - Electrical

2Part 9" Body
Part #1928

2Part Extended Retainer
Part #1940

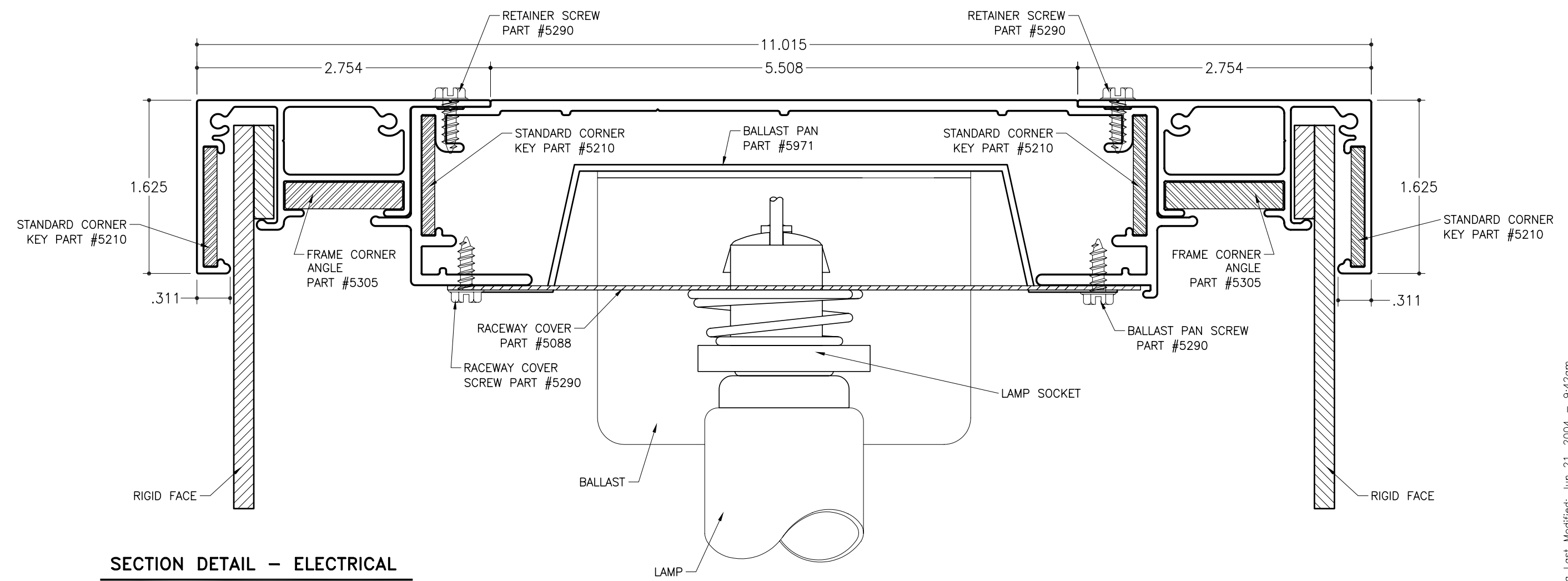

SECTION DETAIL - ELECTRICAL

SCALE : 1" = 1"

- NOTES:
1. Add 1½" to 1¾" to the overall width or height of cabinet depending on which direction the lamps will be placed. (vertical or horizontal)
 2. SignComp does not supply the ballast(s), lamps or lamp sockets.

STD-12 for Rigid Faces – Structural Corner

2Part 9" Body
Part #1928

2Part Extended Retainer
Part #1940

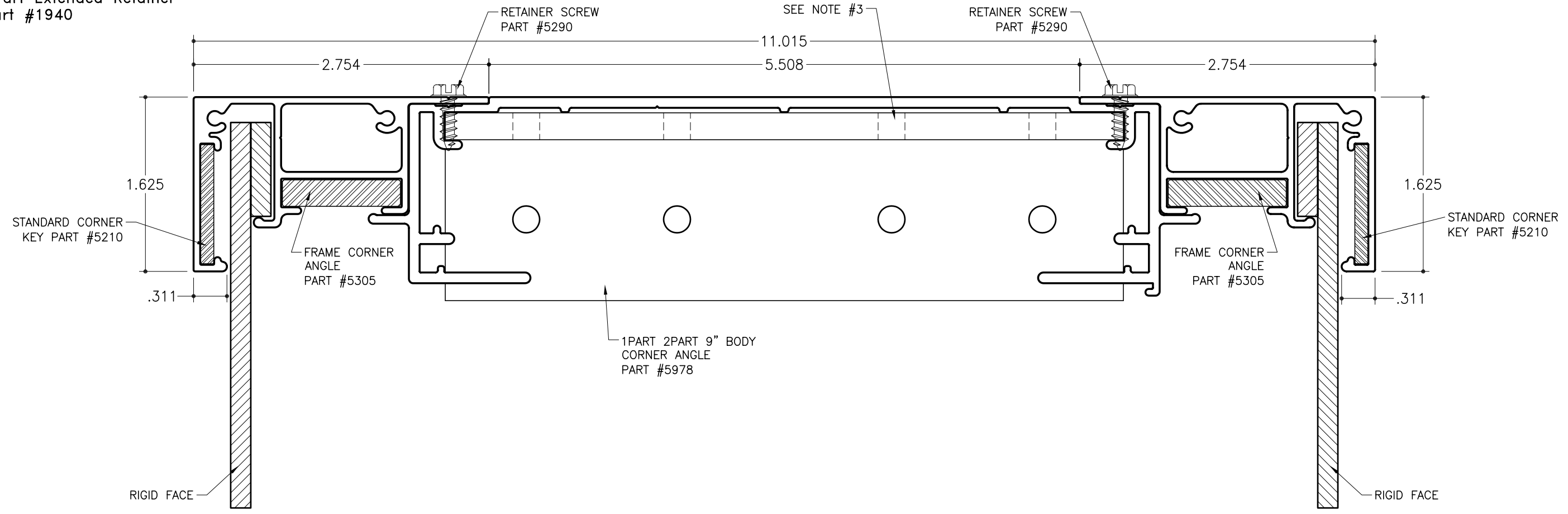

SECTION DETAIL – ADHESIVE BONDED
SCALE : 1" = 1"

- NOTES:
1. Add 1½" to 1¾" to the overall width or height of cabinet depending on which direction the lamps will be placed. (vertical or horizontal)
 2. Hanging bar to be attached to back side of face. Attach hanging bar using mechanical fasteners or adhesive. (SEE DETAIL "A")
 3. Holes located in corner angles are adhesive injection points.

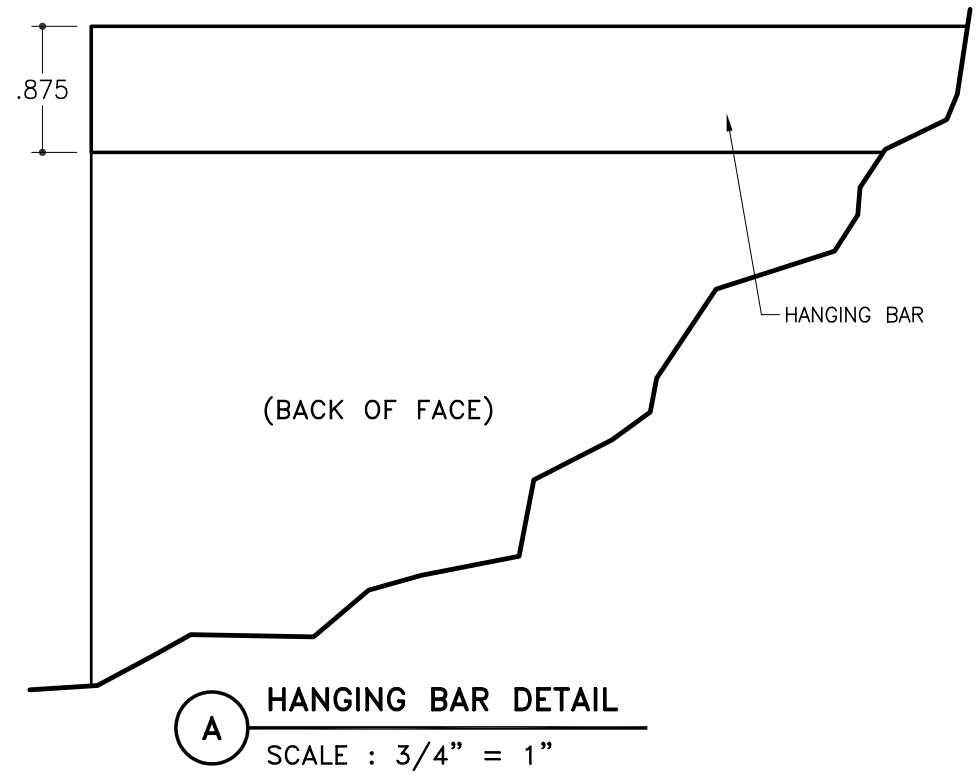

A HANGING BAR DETAIL
SCALE : 3/4" = 1"

STD-12 for Rigid Faces - Structural Corner

2Part 9" Body
Part #1928

2Part Extended Retainer
Part #1940

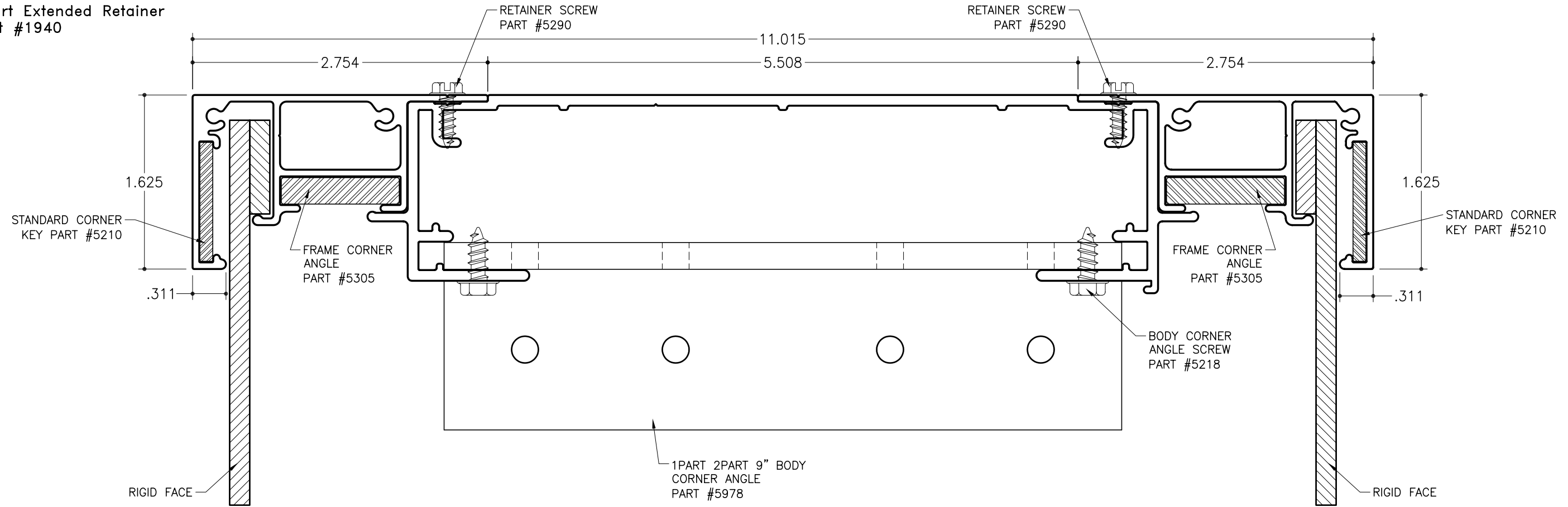

SECTION DETAIL - MECHANICALLY FASTENED

SCALE : 1" = 1"

- NOTES:
1. Add 1½" to 1¾" to the overall width or height of cabinet depending on which direction the lamps will be placed. (vertical or horizontal)
 2. Hanging bar to be attached to back side of face. Attach hanging bar using mechanical fasteners or adhesive. (SEE DETAIL "A")

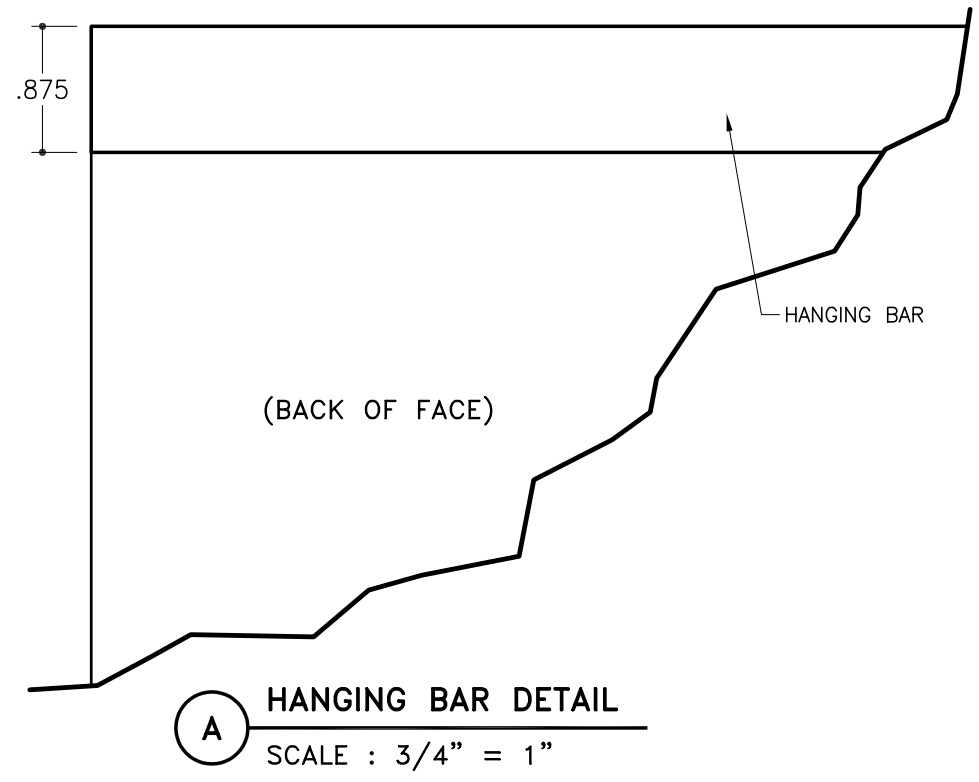

HANGING BAR DETAIL

SCALE : 3/4" = 1"

STD-12 for Rigid Faces – Structural Corner

2Part 9" Body
Part #1928

2Part Extended Retainer
Part #1940

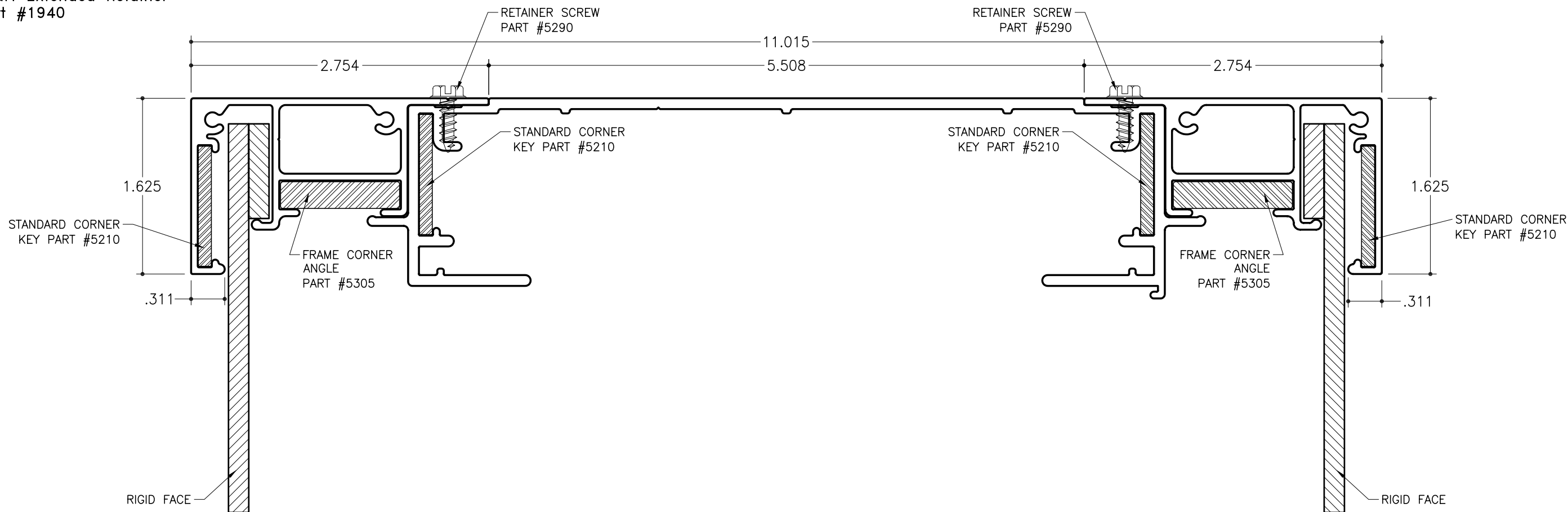

CORNER DETAIL – CORNER KEYS / WELDED

SCALE : 1" = 1"

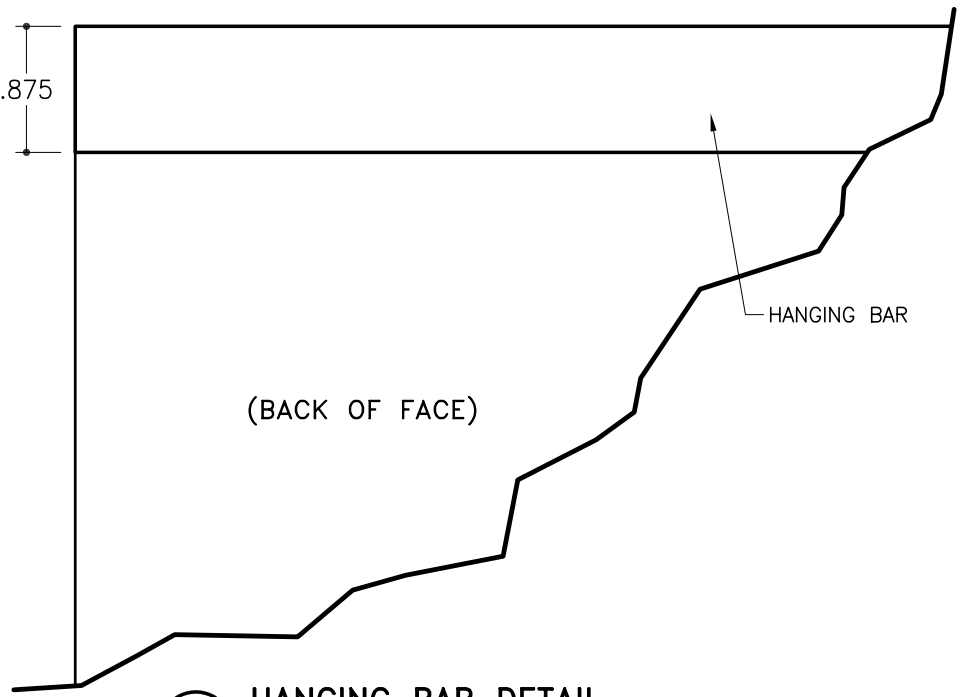

A HANGING BAR DETAIL
SCALE : 3/4" = 1"

- NOTES:
1. Add 1½" to 1¾" to the overall width or height of cabinet depending on which direction the lamps will be placed. (vertical or horizontal)
 2. Hanging bar to be attached to back side of face. Attach hanging bar using mechanical fasteners or adhesive. (SEE DETAIL "A")

STD-12 for Rigid Faces - Side

2Part 9" Body
Part #1928

2Part Extended Retainer
Part #1940

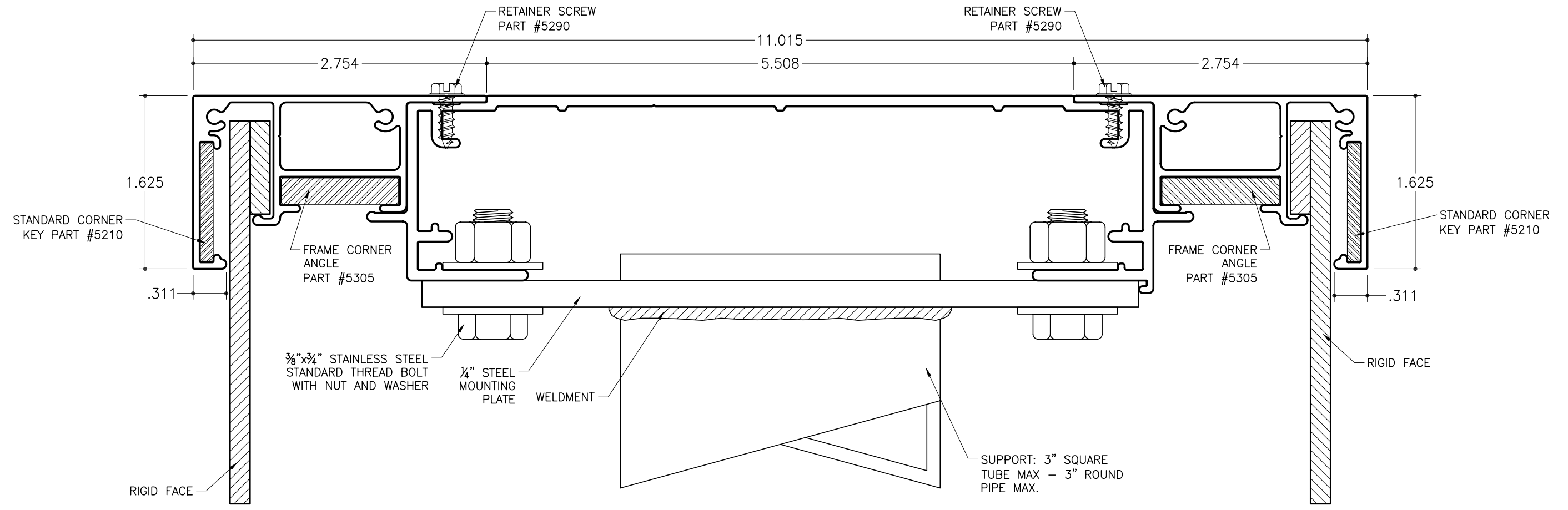

SECTION DETAIL - SIDE

SCALE : 1" = 1"

NOTES:

1. Add 1½" to 1¾" to the overall width or height of cabinet depending on which direction the lamps will be placed. (vertical or horizontal)
2. Max Support: 3" Square Tube or 3" Round Pipe Support.

STD-12 for Rigid Faces - Side

2Part 9" Body
Part #1928

2Part Extended Retainer
Part #1940

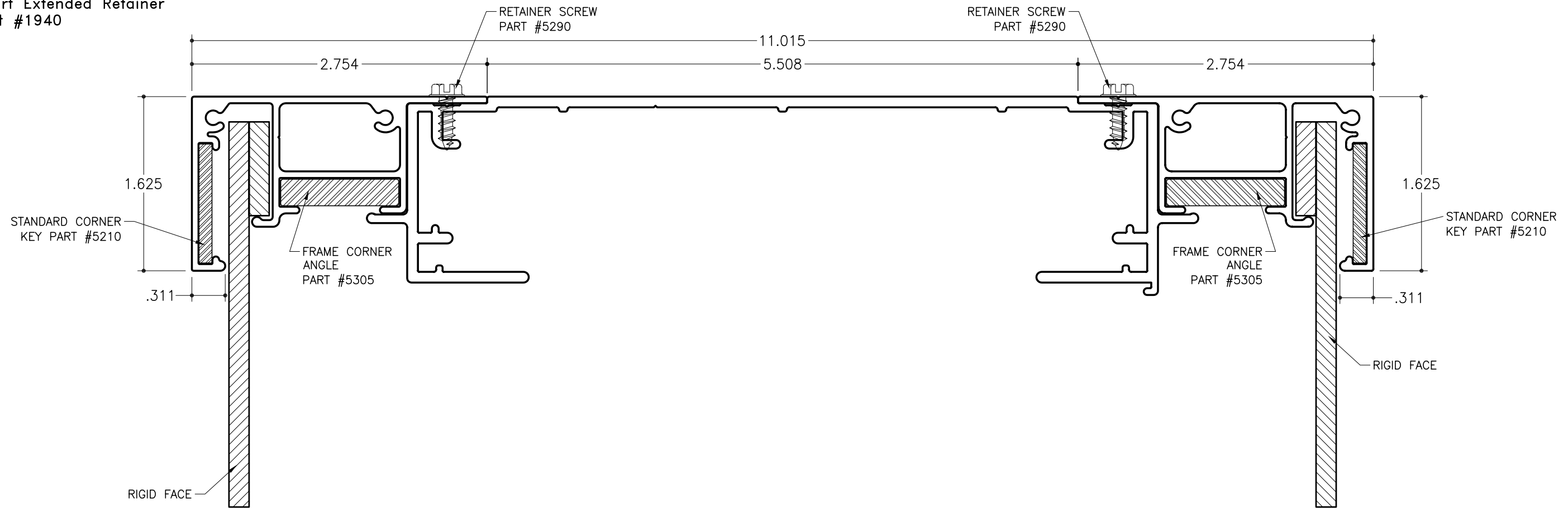

SECTION DETAIL - SIDE
SCALE : 1" = 1"

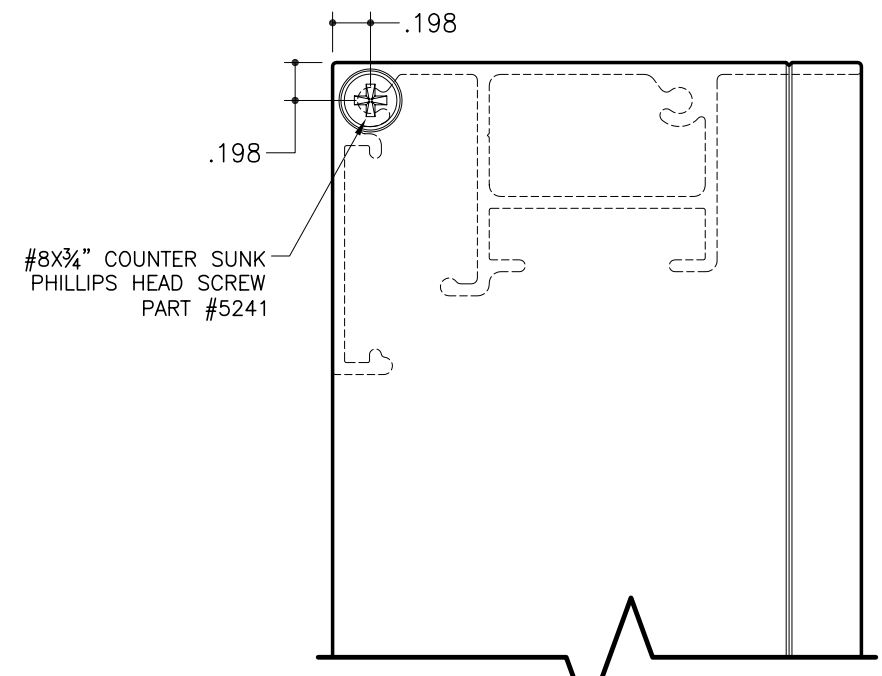

A SIDE VIEW
SCALE : 1"=1"

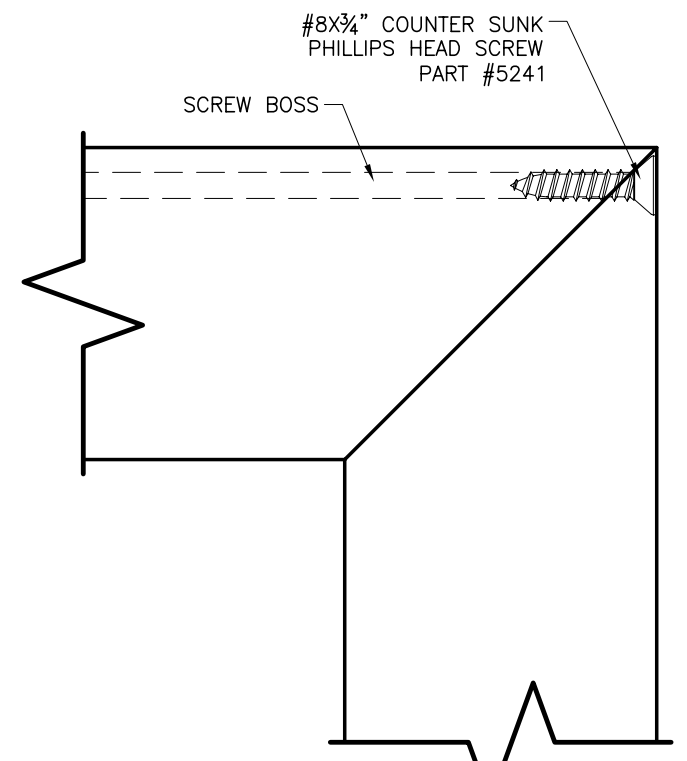

B FACE VIEW
SCALE : 1"=1"

- NOTES:
1. Add 1 1/2" to 1 3/4" to the overall width or height of cabinet depending on which direction the lamps will be placed. (vertical or horizontal)
 2. 2Part Extended Retainer has two (2) screw boss for fastening to insure a tight fit. Only the outside screw boss is used when it is attached to the 2Part bodies.