

SC-17 for Flex Faces - Electrical

Wide Body
 Part #2005

Tension Frame
 Part #2085

Bleed Tension Frame Cover
 Part #2095

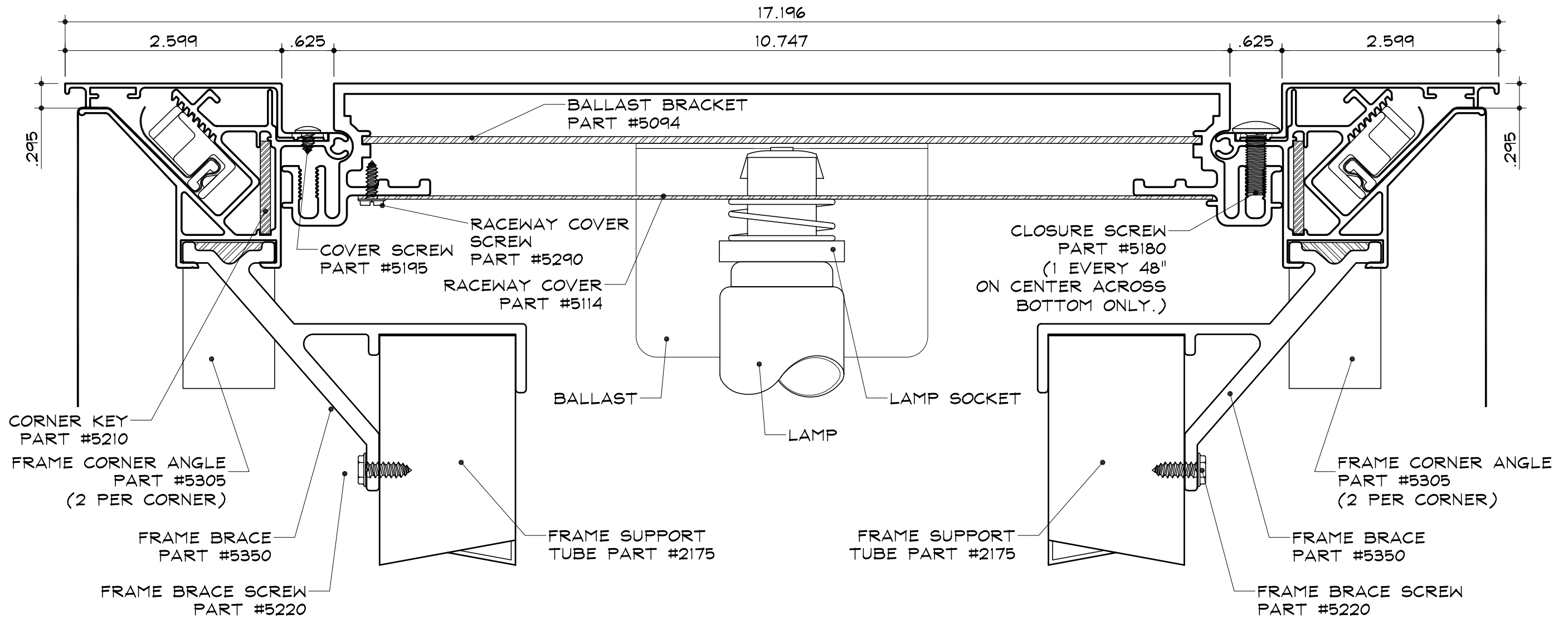

SECTION DETAIL

SCALE : 3/4" = 1"

NOTES:

1. Add 1" to size of cabinet (vertical or horizontal) when the size of the cabinet is the same as the nominal lamp length.

2. SignComp does not supply the Ballast, Lamp, Lamp Socket.

SC-17 for Flex Faces - Structural (Corner)

Wide Body
 Part #2005

Tension Frame
 Part #2085

Bleed Tension Frame Cover
 Part #2095

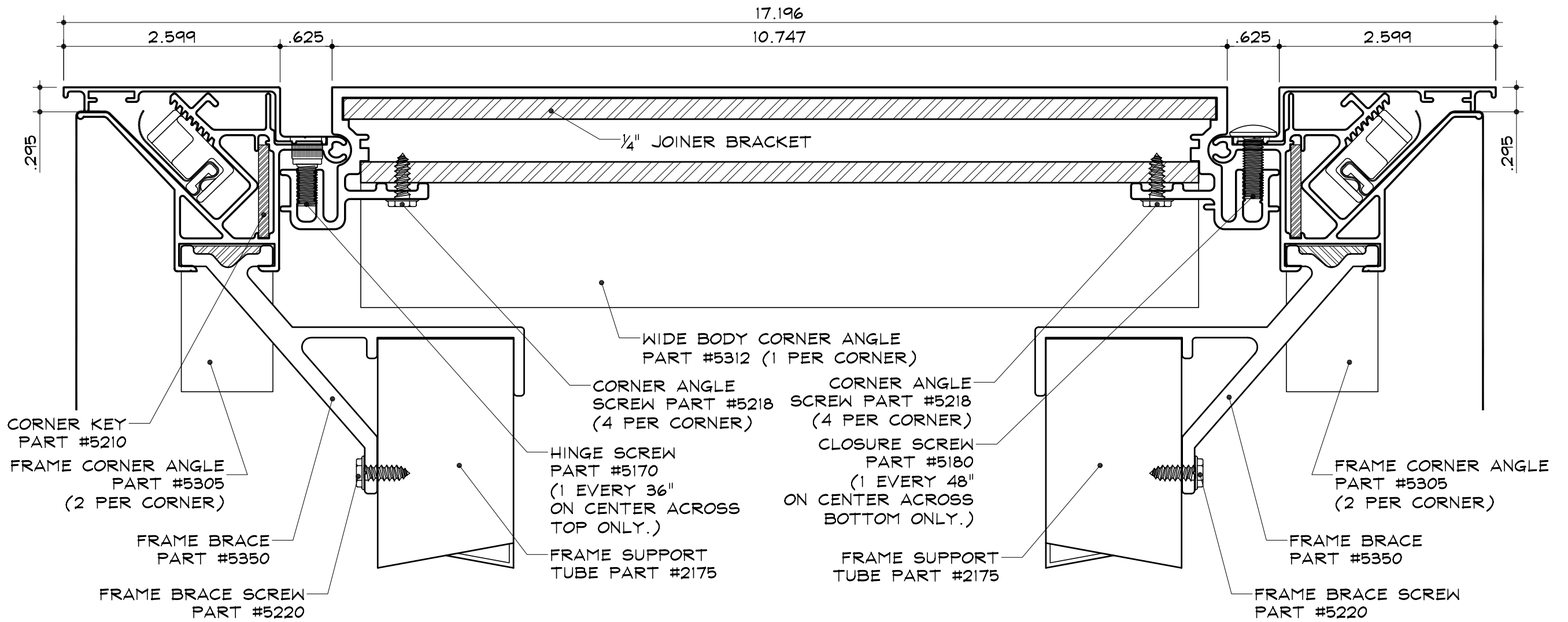

CORNER SECTION DETAIL

SCALE : 3/4" = 1"

NOTES:

1. Add 1" to size of cabinet (vertical or horizontal) when the size of the cabinet is the same as the nominal lamp length.
2. SignComp does not supply the 1/4" Joiner Bracket.

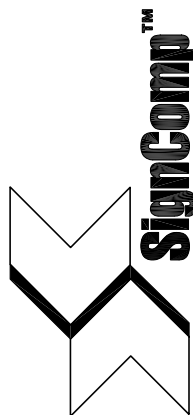

SC-17 for Flex Faces - Structural (Corner)

Wide Body
 Part #2005

Tension Frame
 Part #2085

Bleed Tension Frame Cover
 Part #2095

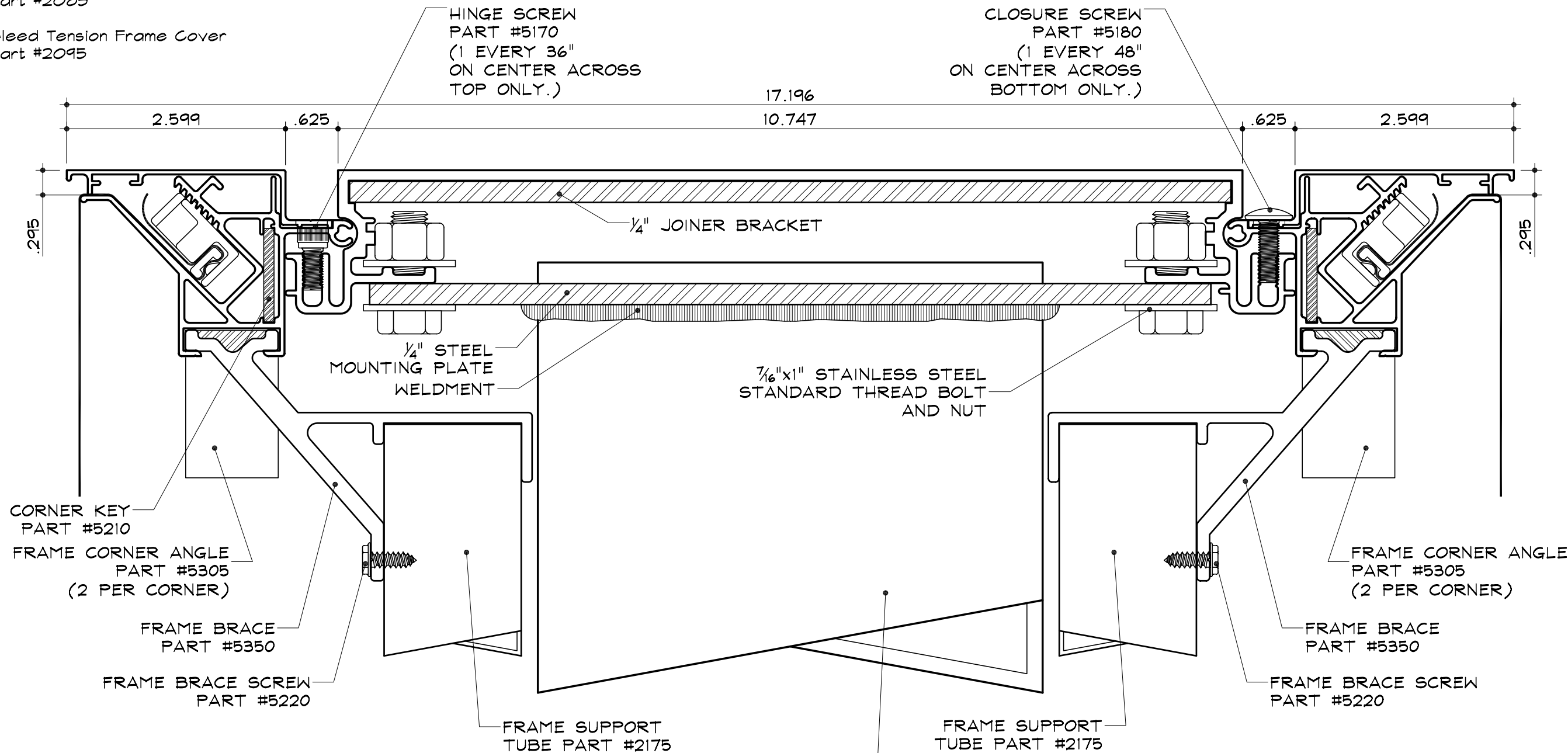

SUPPORT SECTION DETAIL

SCALE : 3/4" = 1"

NOTES:

1. Add 1" to size of cabinet (vertical or horizontal) when the size of the cabinet is the same as the nominal lamp length.
2. SignComp does not supply the 1/4" Joiner Bracket, 1/4" Mounting Plate, 7/16" Mounting bolts or Support.
3. Max support size to be used 6" Square Tube.

****NOTE:****
 FRAME BRACES AND SUPPORT TUBES SHOULD NOT BE PLACE IN FRONT OF SUPPORT TUBE OR PIPE.