

SC-7 for Rigid Faces - Electrical

Medium Body
Part #2015

1/2" Retainer
Part #2055

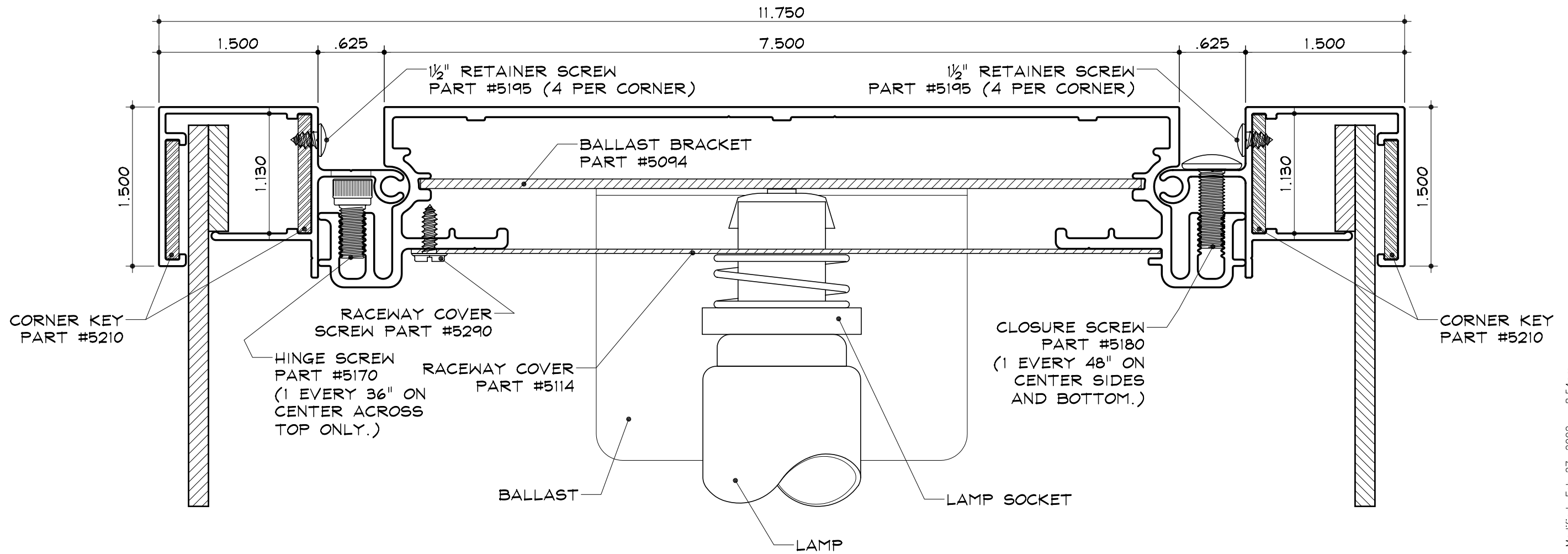

SECTION DETAIL
SCALE : 1" = 1"

NOTES:

1. Add 1" to size of cabinet (vertical or horizontal) when the size of the cabinet is the same as the nominal lamp length.
2. SignComp does not supply the Ballast(s), Lamps, or Lamp Sockets.

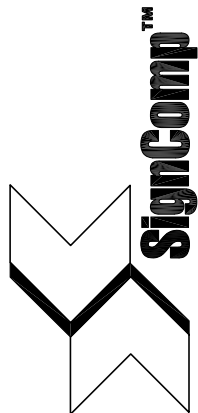

SC-7 for Rigid Faces - Structural (Corner)

Medium Body
 Part #2015

1/2" Retainer
 Part #2055

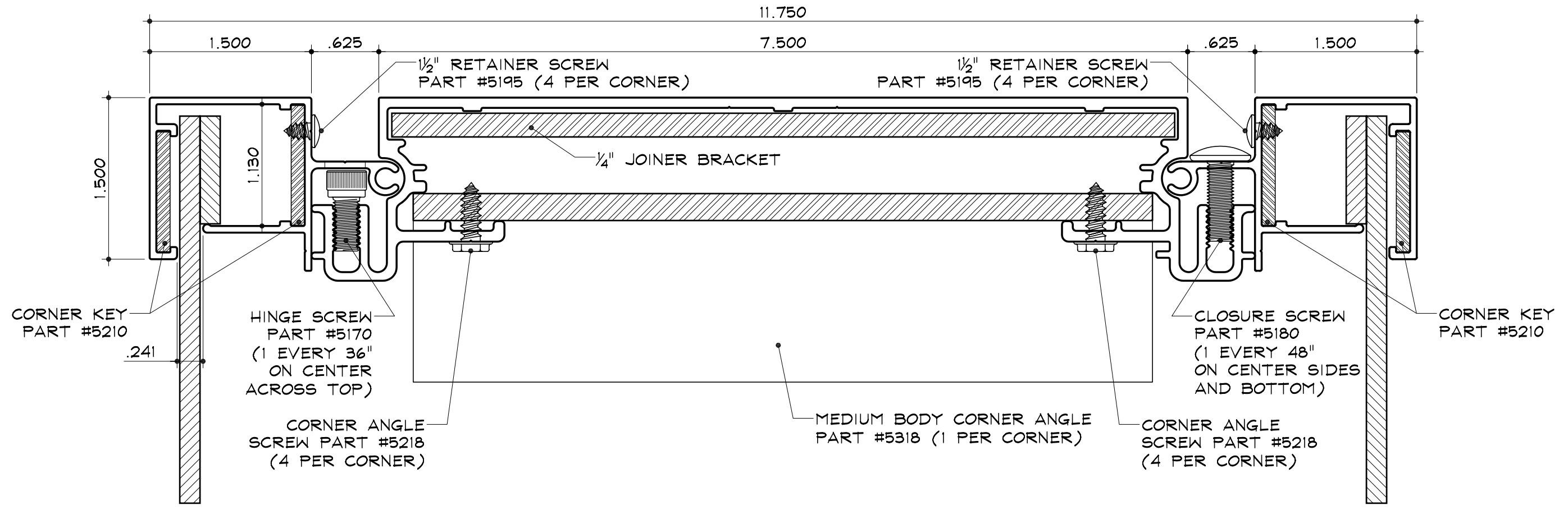

CORNER SECTION DETAIL

SCALE : 1" = 1"

NOTES:

1. Add 1" to size of cabinet (vertical or horizontal) when the size of the cabinet is the same as the nominal lamp length.
2. SignComp does not supply the 1/4" Joiner Bracket.

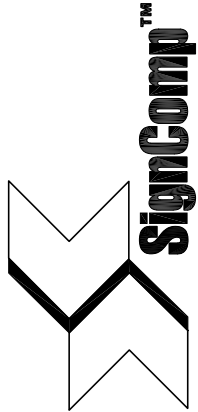

SC-7 for Rigid Faces - Structural (Corner)

Medium Body
 Part #2015

1/2" Retainer
 Part #2055

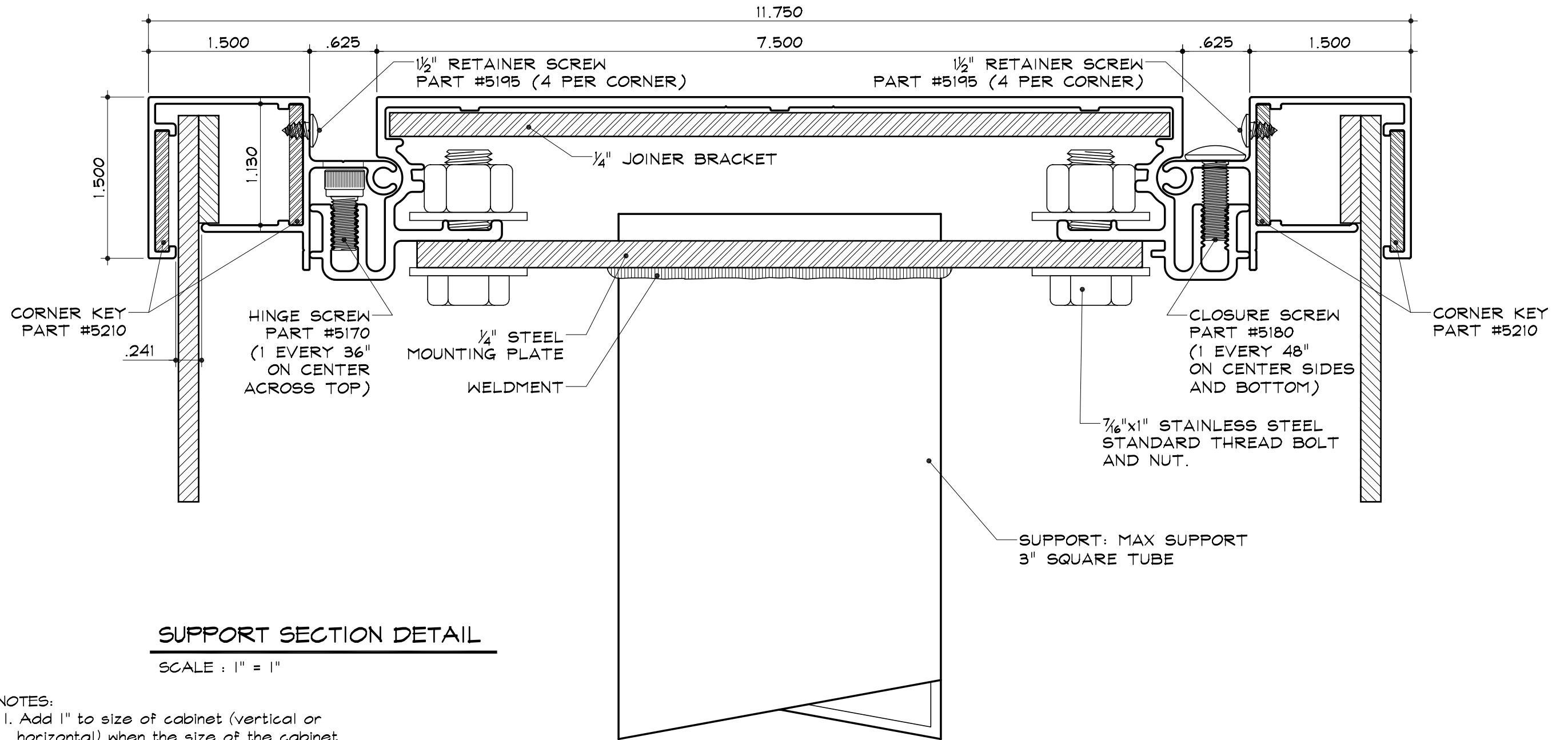

SUPPORT SECTION DETAIL

SCALE : 1" = 1"

NOTES:

1. Add 1" to size of cabinet (vertical or horizontal) when the size of the cabinet is the same as the nominal lamp length.
2. SignComp does not supply the 1/4" Joiner Bracket, 1/4" Mounting Plate, 7/16" Mounting bolts or Support.
3. Max support size to be used 3" Square Tube.

