

SC-26 for Flex Faces

Flat Bleed Retro Frame
Part #2104

Flat Bleed Retro Frame Cover
Part #2121

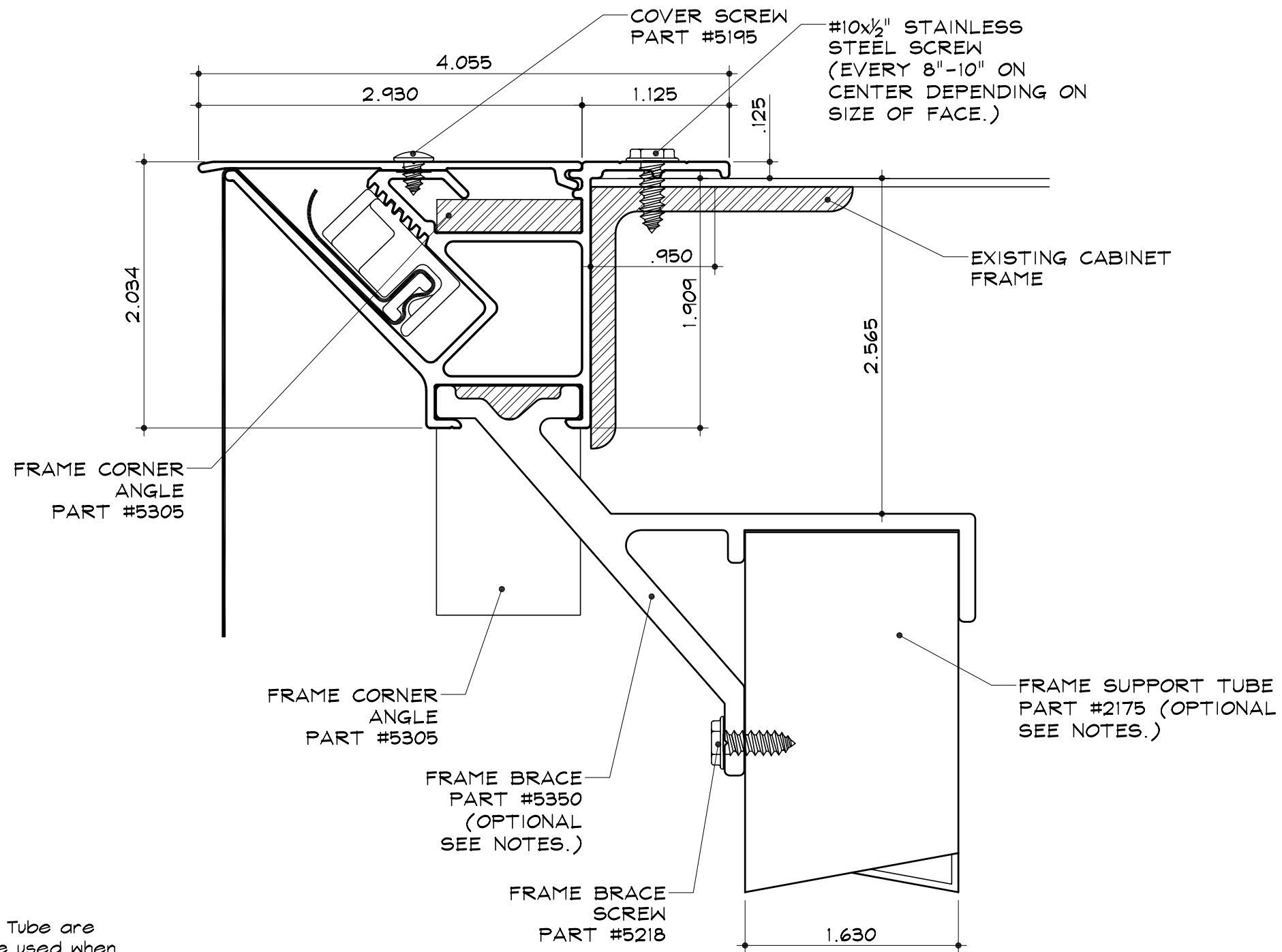

NOTES:

Frame Brace and Frame Support Tube are optional. We recommend that it be used when the following conditions are present.

1. - The Retro Frame is mounted with a piano hinge and face would be hinged open for servicing.
2. - The existing cabinet needs additional strength for tension, wind load or cabinet frame is not fabricated from steel.
3. - The face will be tensioned in the Retro Frame before taking it to the site for installation.

SECTION DETAIL

SCALE : 1" = 1"

