

STD-1 for Rigid Faces - Electrical

1 Part S/F Body
Part #1922

2 Part S/F Body
Part #1927

2 Part Retainer
Part #1944

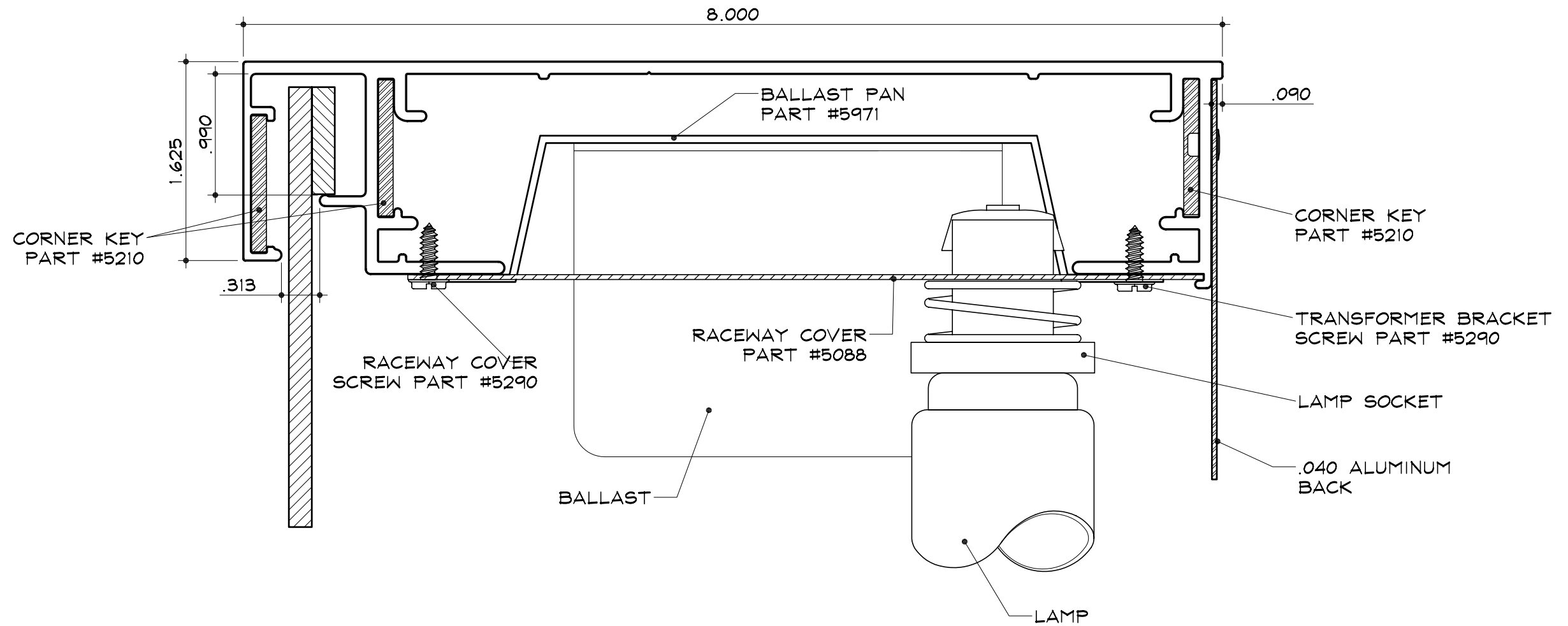

SECTION DETAIL

SCALE : 1" = 1"

NOTES:

1. Add 1/2" to size of cabinet (vertical or horizontal) when the size of the cabinet is the same as the nominal lamp length.
2. SignComp does not supply the Ballast(s), Lamps, Lamp Sockets or the .040 Aluminum Back.

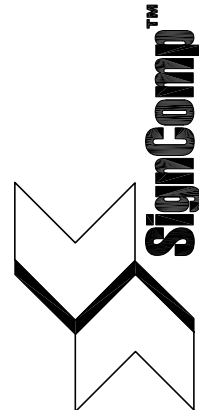

STD-1 for Rigid Faces - Structural

- 1 Part S/F Body
Part #1922
- 2 Part S/F Body
Part #1927
- 2 Part Retainer
Part #1944

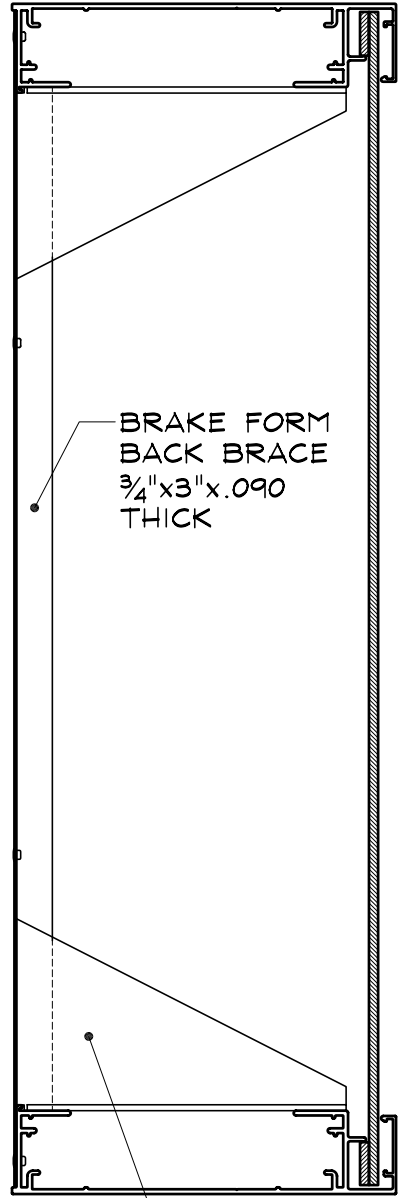

BRAKE FORM
BACK BRACE
3/4"x3"x.090
THICK

1/8" ALUMINUM
GUSSET

FULL SECTION

SCALE : 3" = 1"

NOTES:

1. Add 1/2" to 1 3/4" to size of cabinet (vertical or horizontal) when the size of the cabinet is the same as the nominal lamp length.
2. SignComp does not supply the Material for Gussets, Back Brace, or .040 Aluminum Back.

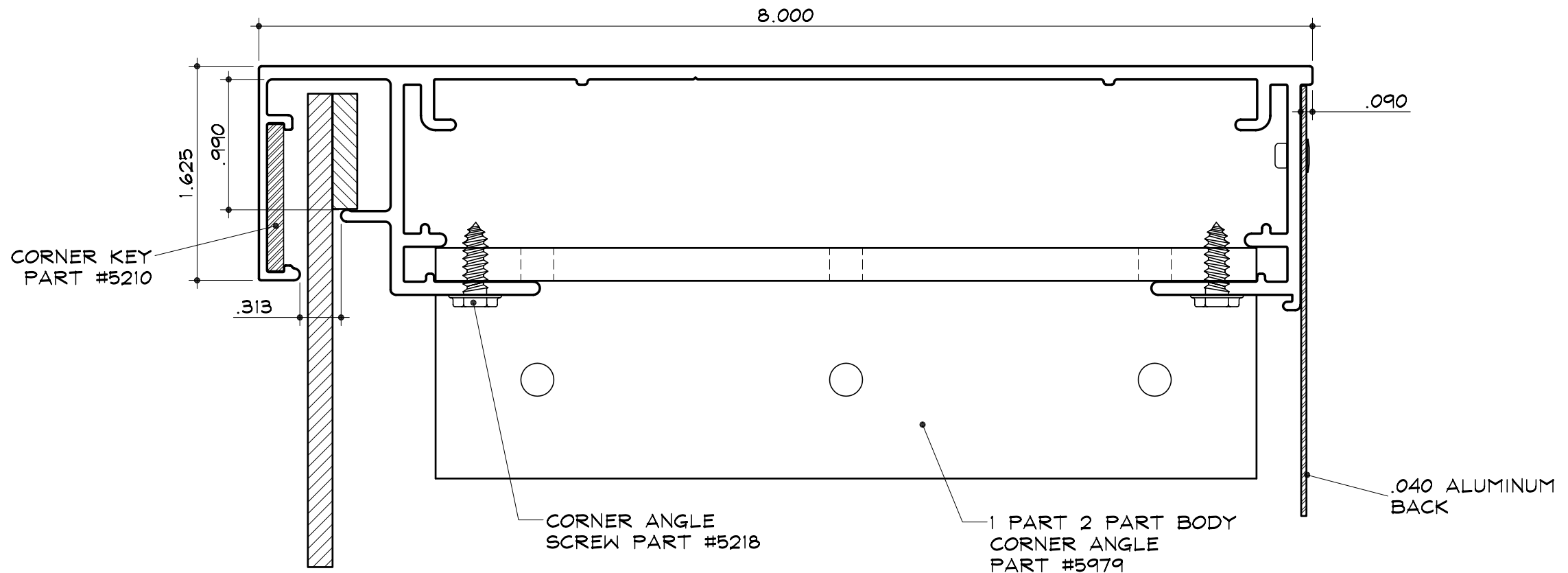

CORNER KEY
PART #5210

CORNER ANGLE
SCREW PART #5218

1 PART 2 PART BODY
CORNER ANGLE
PART #5979

.040 ALUMINUM
BACK

CORNER SECTION DETAIL (MECHANICALLY FASTENED CORNER ANGLE)

SCALE : 1" = 1"

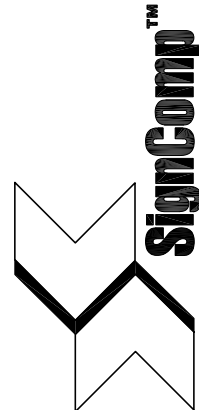

STD-1 for Rigid Faces - Structural

1 Part S/F Body
Part #1922

2 Part S/F Body
Part #1927

2 Part Retainer
Part #1944

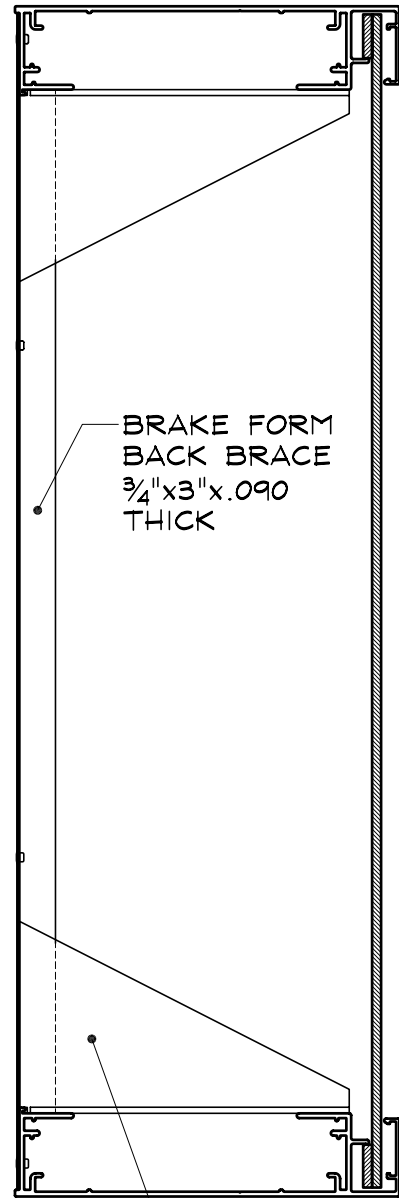

BRAKE FORM
BACK BRACE
3/4"x3"x.090
THICK

1/8" ALUMINUM
GUSSET

FULL SECTION

SCALE : 3" = 1'

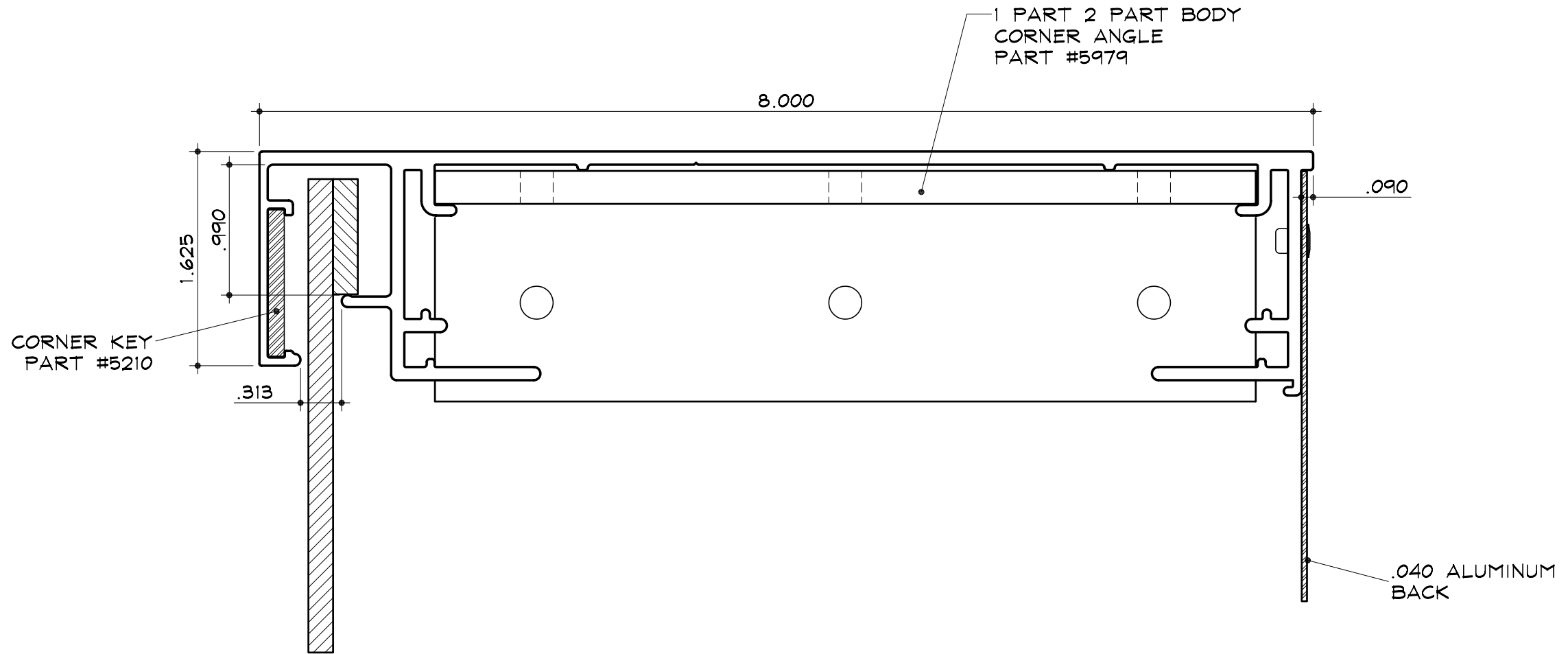

1 PART 2 PART BODY
CORNER ANGLE
PART #5979

8.000

.090

CORNER KEY
PART #5210

1.625

.990

.313

.040 ALUMINUM
BACK

CORNER SECTION DETAIL (GLUED CORNER ANGLE)

SCALE : 1" = 1"

NOTES:

1. Add 1/2" to 1 3/4" to size of cabinet (vertical or horizontal) when the size of the cabinet is the same as the nominal lamp length.
2. SignComp does not supply the Material for Gussets, Back Brace or .040 Aluminum Back.

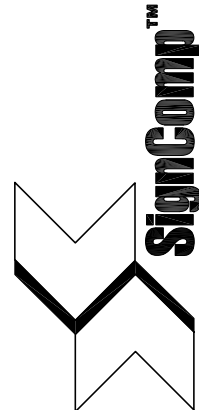

STD-1 for Rigid Faces - Structural

1 Part S/F Body
 Part #1922

2 Part S/F Body
 Part #1927

2 Part Retainer
 Part #1944

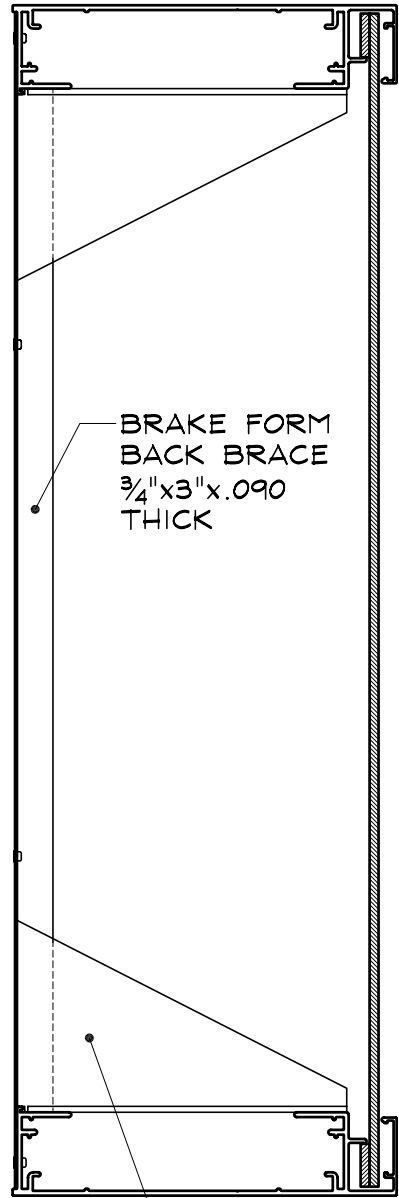

FULL SECTION

SCALE : 3" = 1"

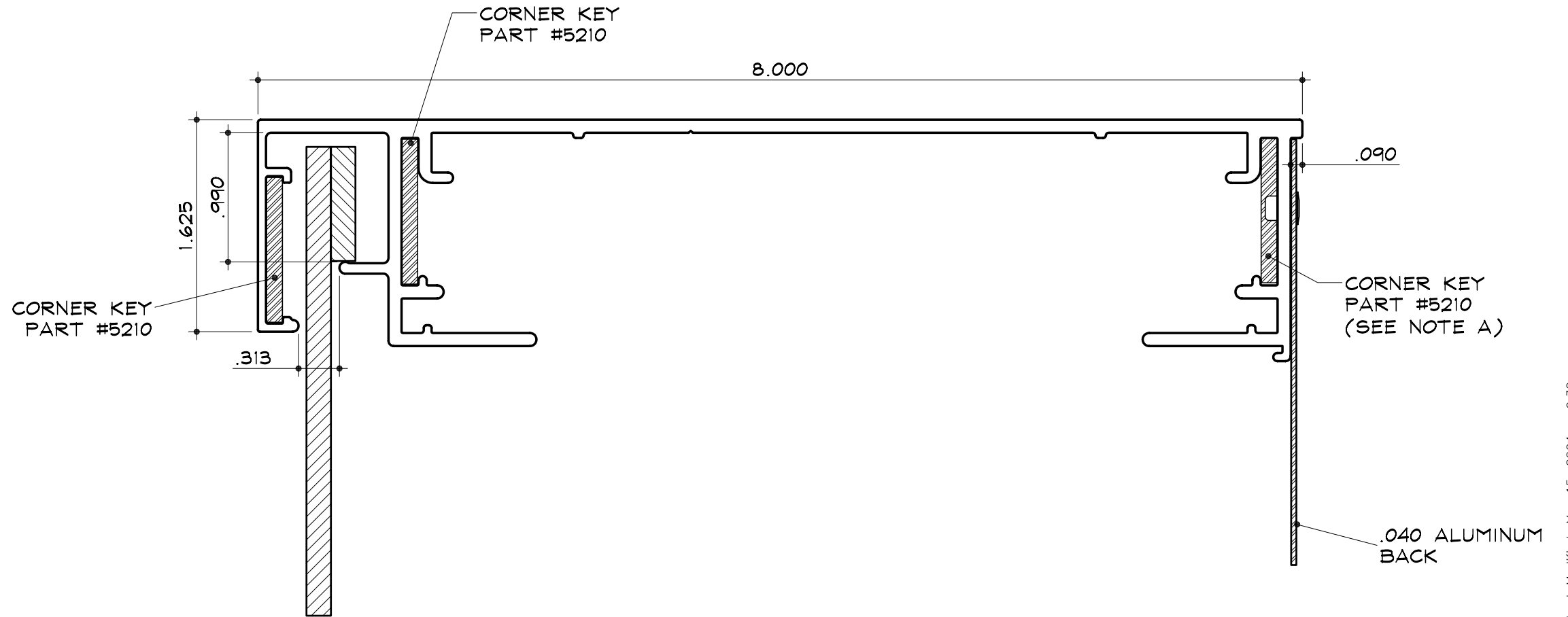

CORNER SECTION DETAIL (WELDED/CORNER KEYS)

SCALE : 1" = 1"

NOTES:

1. Add 1/2" to 1 3/4" to size of cabinet (vertical or horizontal) when the size of the cabinet is the same as the nominal lamp length.
2. SignComp does not supply the Material for Gussets, Back Brace or .040 Aluminum Back.

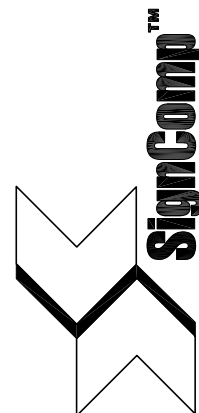

STD-1 for Rigid Faces - Electrical

1 Part S/F Body
Part #1922

2 Part S/F Body
Part #1927

2 Part Retainer
Part #1944

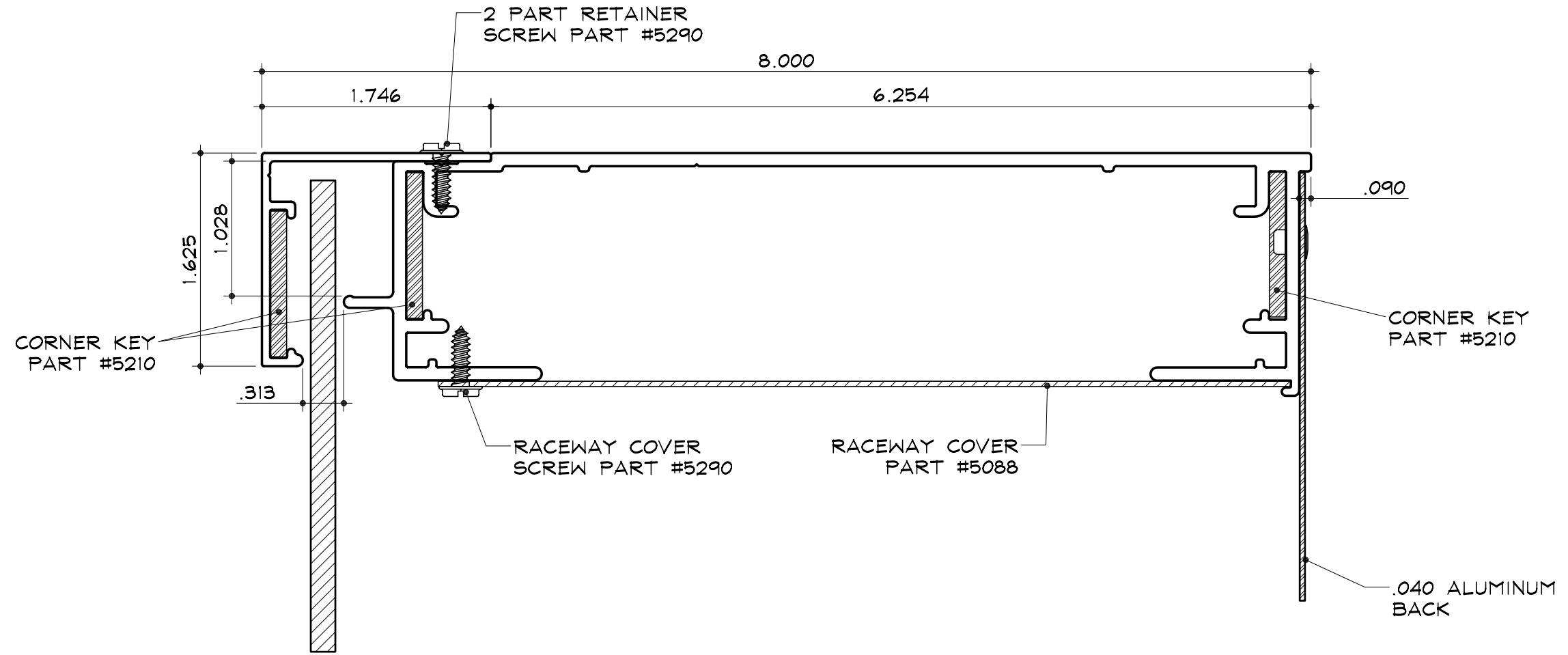

SIDE SECTION DETAIL

SCALE : 1" = 1"

NOTES:

1. Add 1/2" to 1 3/4" to size of cabinet (vertical or horizontal) when the size of the cabinet is the same as the nominal lamp length.
2. SignComp does not supply the .040 Aluminum Back.