

SERIES 1 - 1/8" FACE & POST SYSTEM:

SERIES 1 3/4" SQUARE POST
 PART #1005

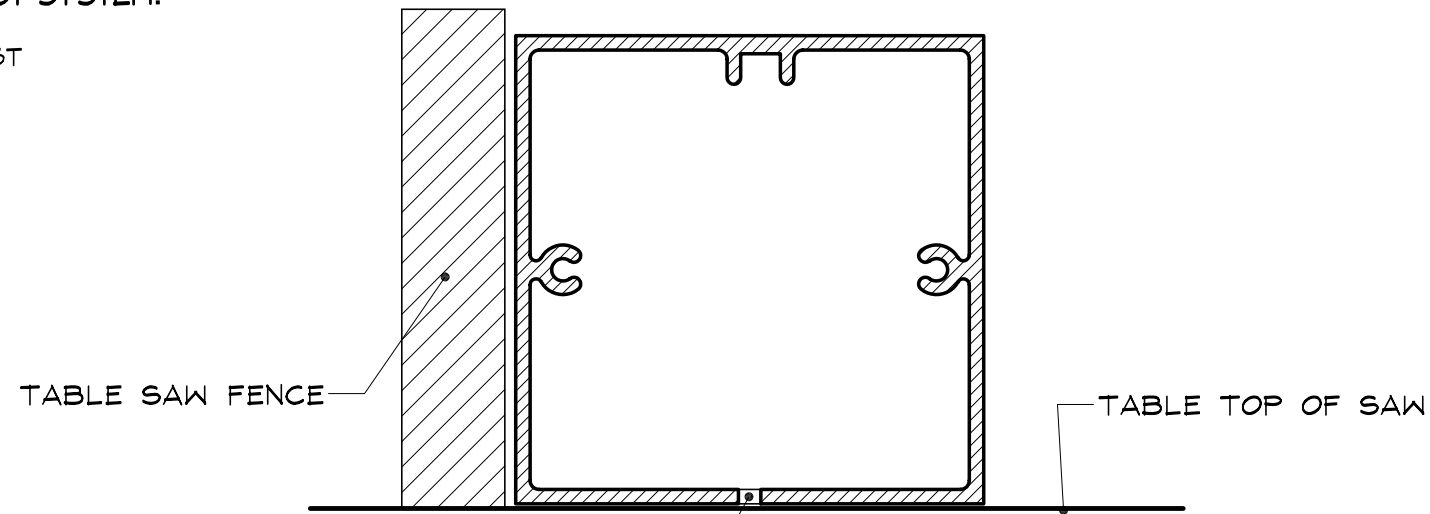

CUT SLOT HERE TO
 ACCEPT THE DESIRED
 HEIGHT OF PANEL.
 (BLADE THICKNESS
 5/32" MIN. - 3/16" MAX.
 FOR SLOTTING.)

SLOTING INSTRUCTIONS

SCALE : 3/4" = 1"

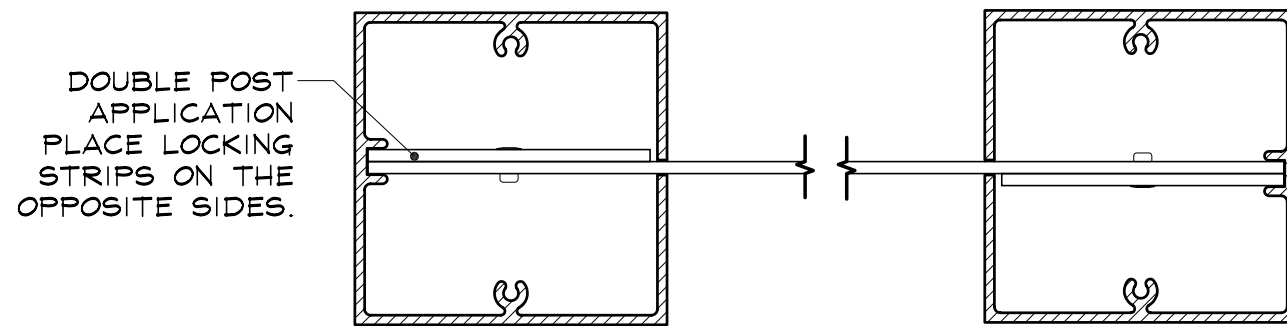

DOUBLE POST DISPLAY

SCALE : 1/2" = 1"

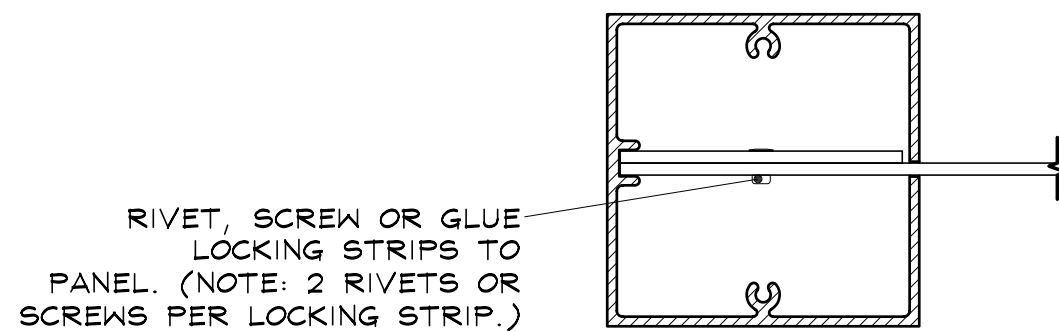

SINGLE POST DISPLAY

SCALE : 1/2" = 1"

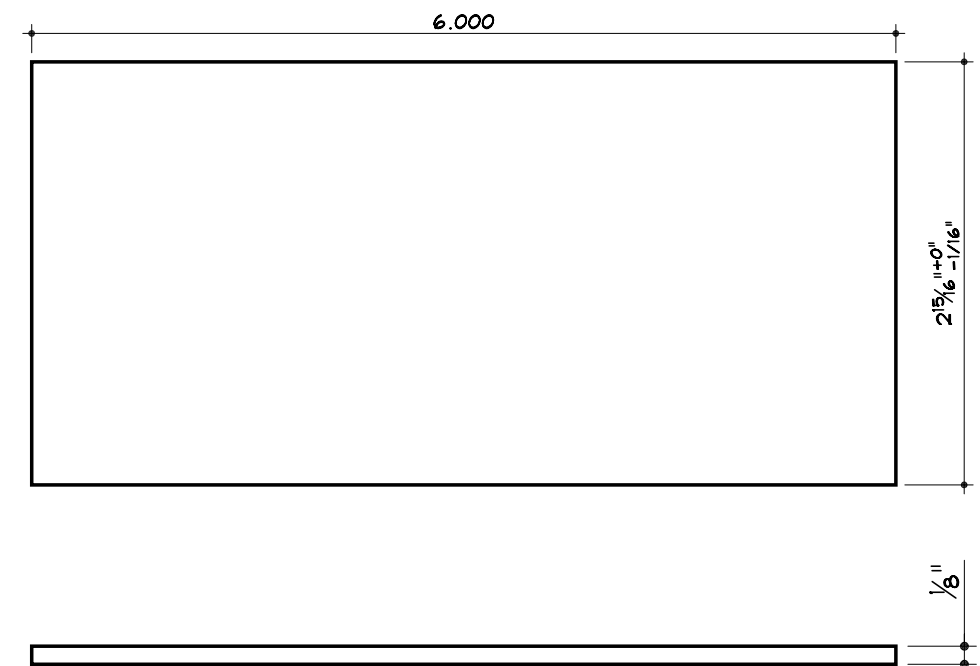
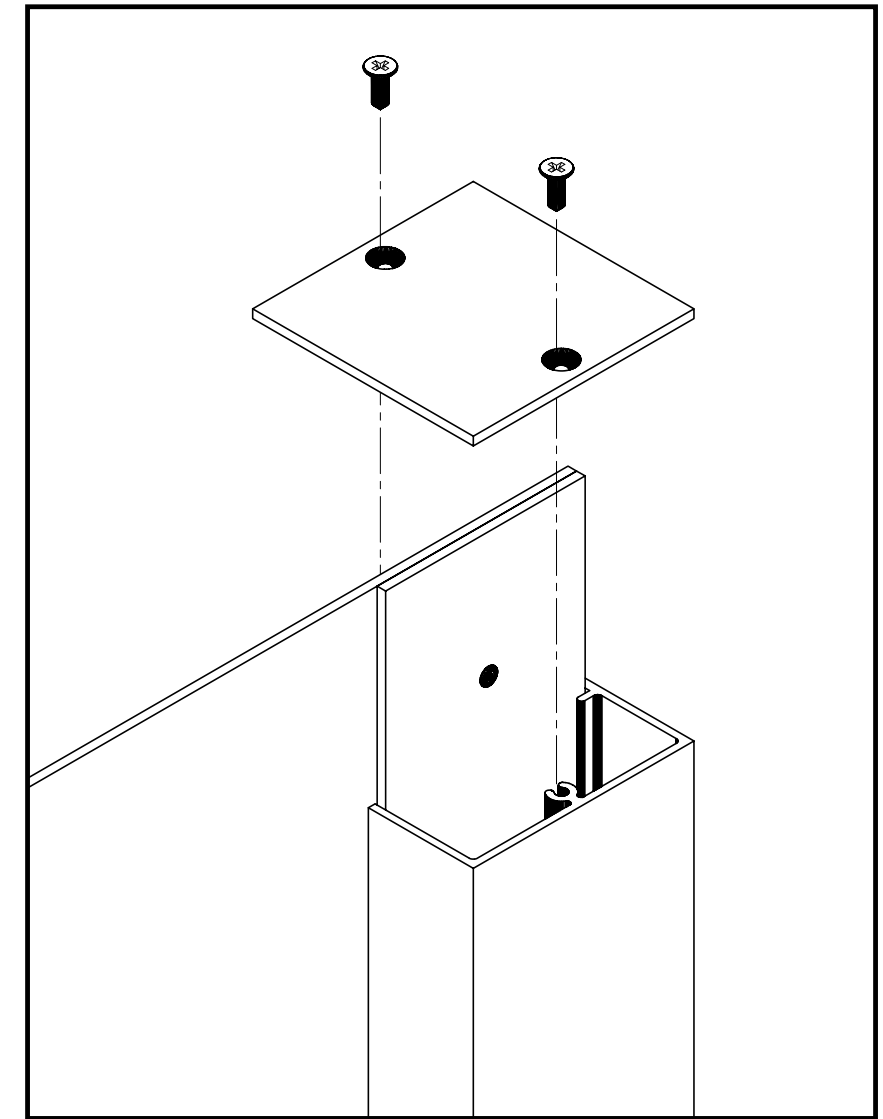

LOCKING STRIP DETAIL

SCALE : 3/4" = 1"

SER 1 - 1005-1