

EC-7 for Rigid Faces - Structural

Econo Divider  
 Part #2140

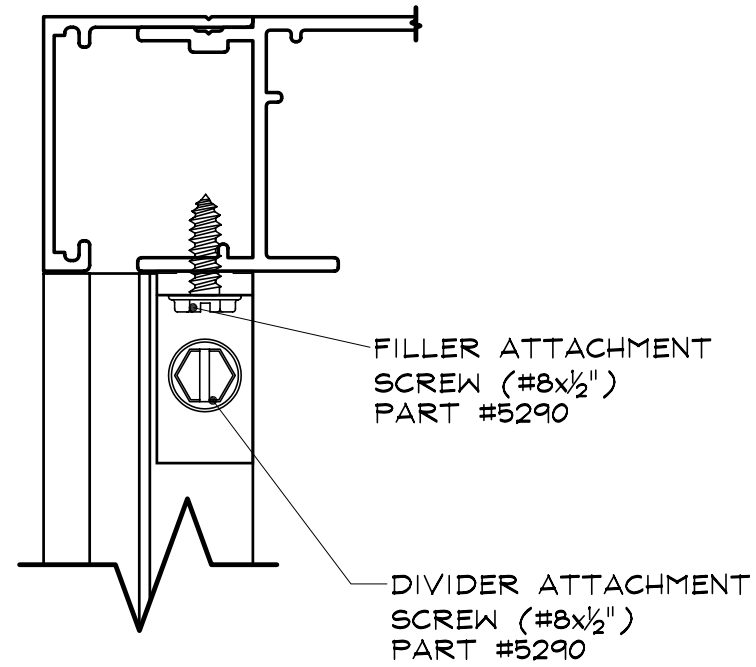

**TOP VIEW**  
 SCALE : 1" = 1"

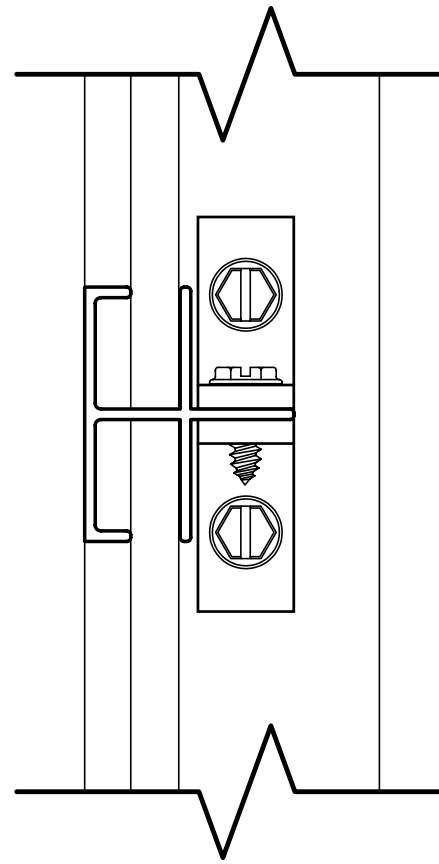

**SIDE VIEW**  
 SCALE : 1" = 1"

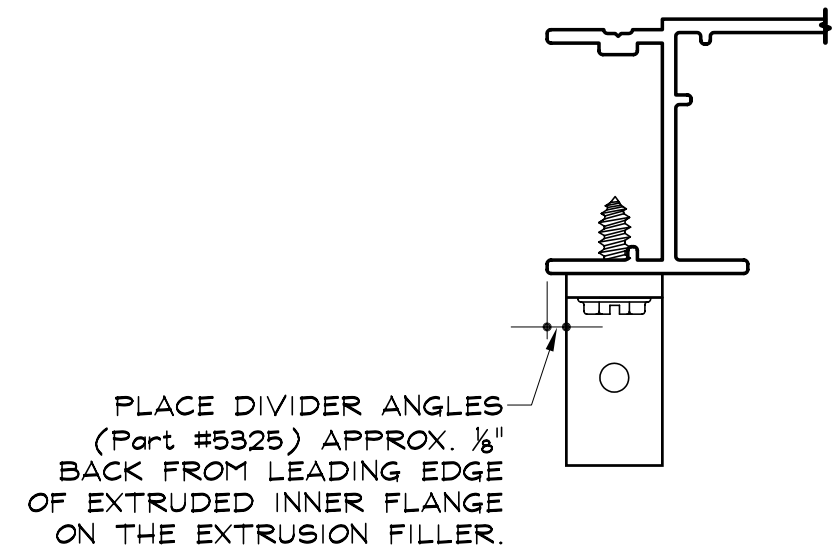

**A SECTION DETAIL**  
 SCALE : 1" = 1"

NOTES:

1. Place Divider Angles, Part #5325 approx.  $\frac{1}{8}$ " back from leading edge of filler see detail "A".