

EC-4 for Rigid Faces - Corner

Medium Double Filler
Part #2036

Econo Molding
Part #2056

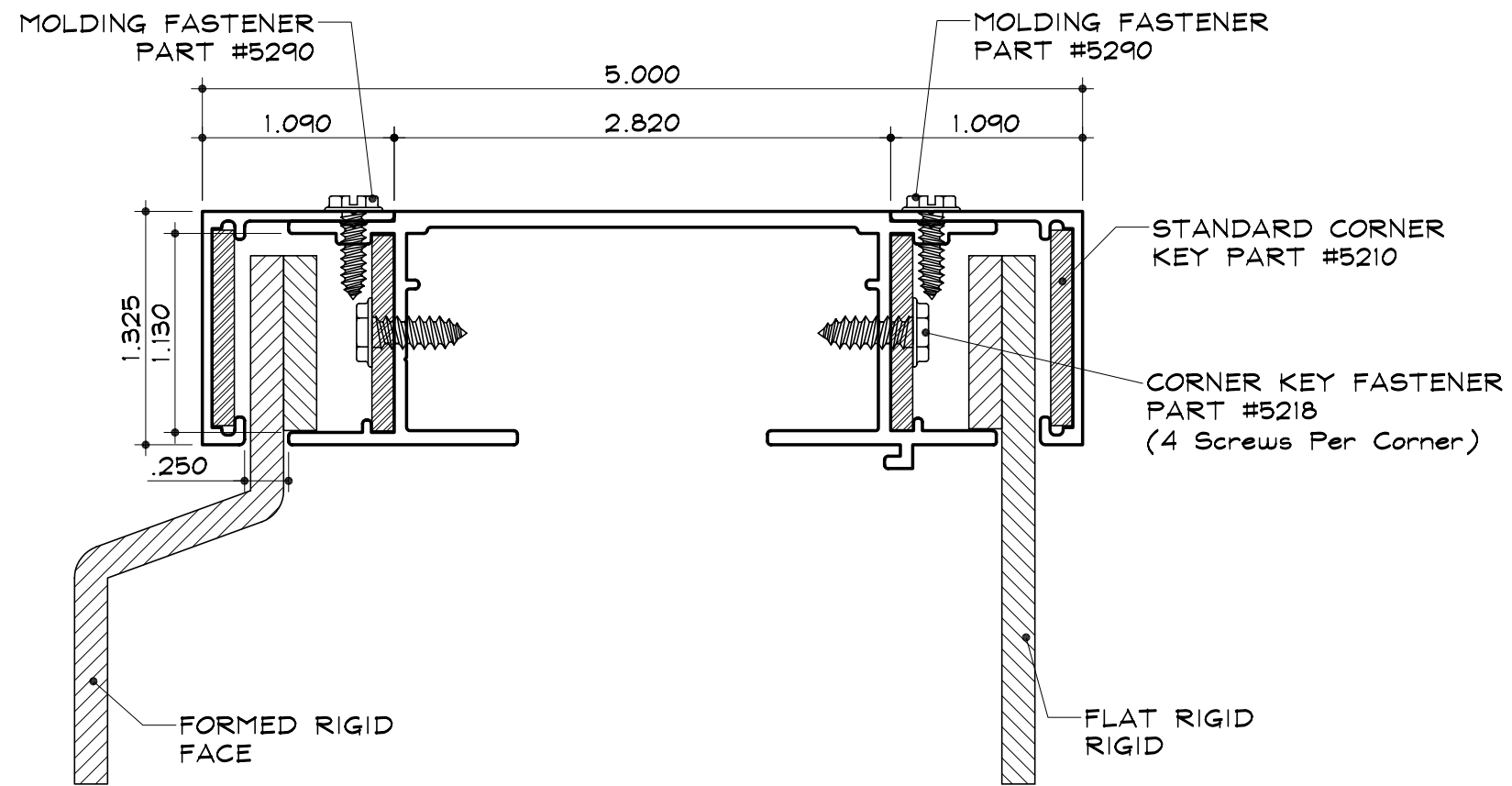

SECTION DETAIL

SCALE : 1" = 1"

EC-4 for Rigid Faces - Structural

Medium Double Filler
 Part #2036

Econo Molding
 Part #2056

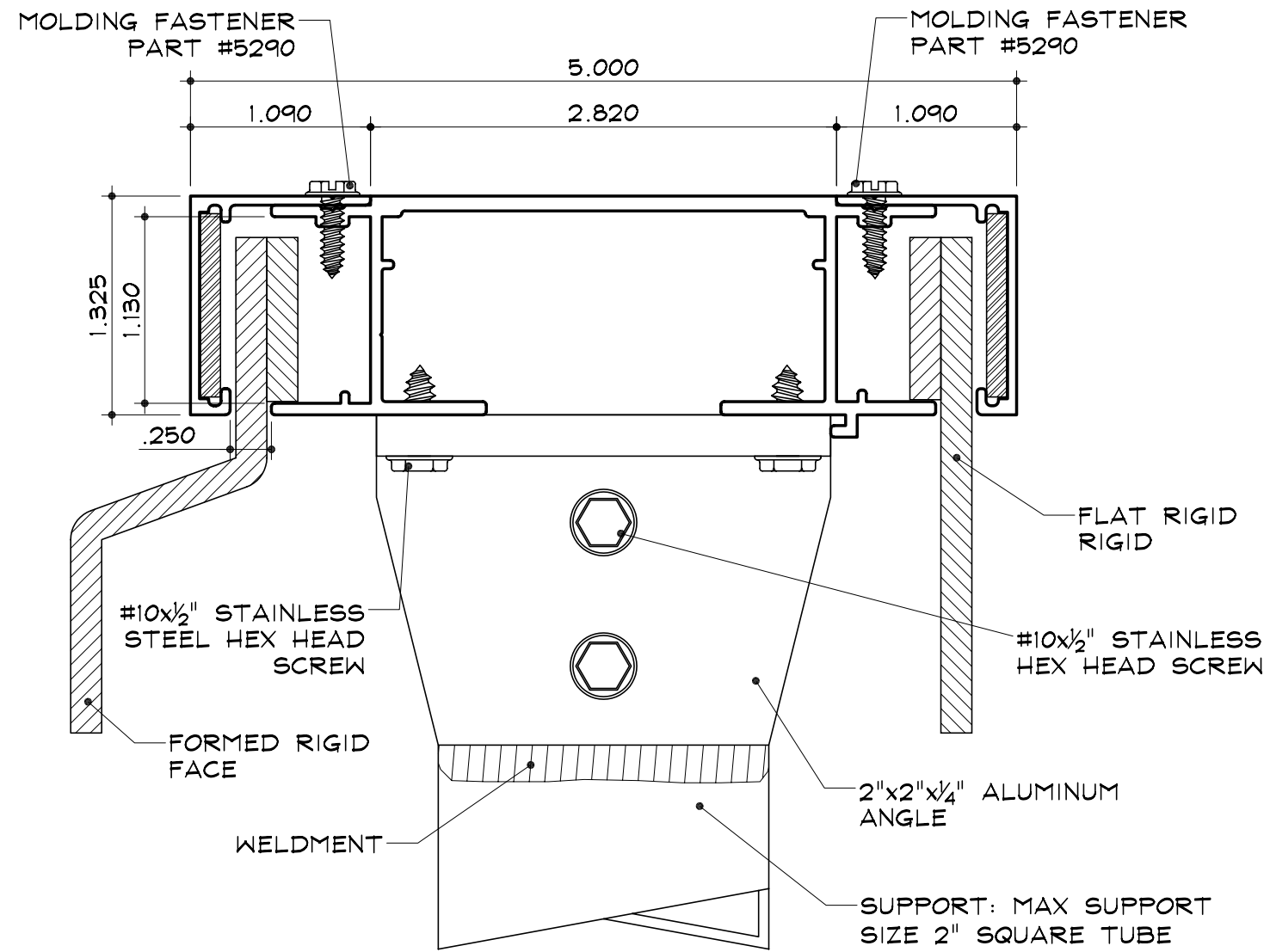

SUPPORT SECTION DETAIL

SCALE : 1" = 1"

NOTES:

1. SignComp does not supply the Mounting Angles/Mounting plate, Mounting Screws, Support or Joiner Bracket.
2. Substituting or adding 1/4" plate stock for angles will increase the strength of the cabinet.
3. Max support size to be used 2" square tube.

