

EC-6 for Rigid Faces - Electrical

Single Face Filler
 Part #2034

Extended Econo Molding
 Part #2058

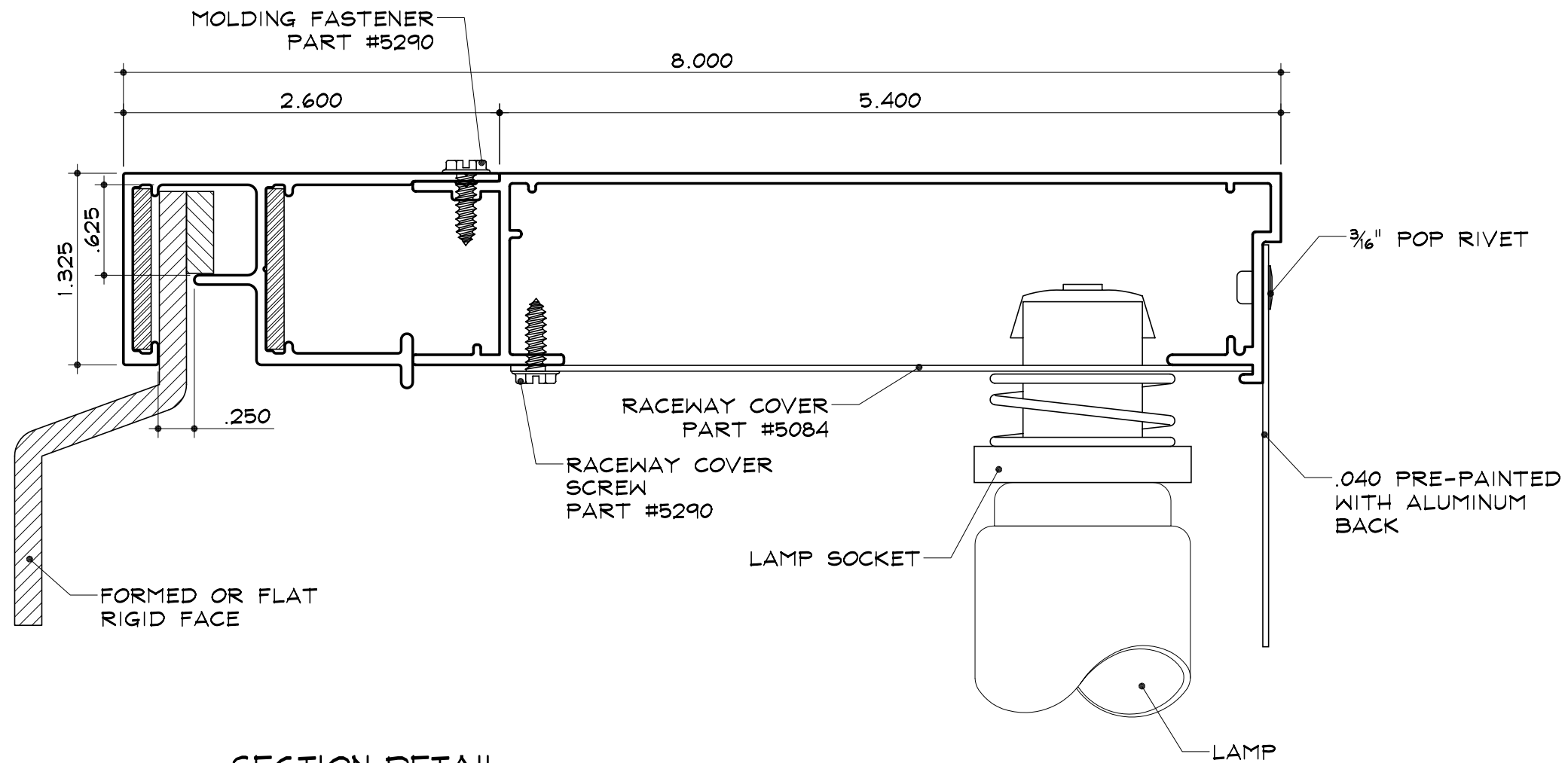

SECTION DETAIL

SCALE : 1" = 1"

NOTES:

1. Add 1" to the size of the cabinet (vertical or horizontal) when the size of the cabinet is the same as the nominal lamp length.
2. SignComp does not supply the Ballast(s), Lamps, Lamp Sockets, Raceway Covers, Raceway Cover Screws or Aluminum Back.

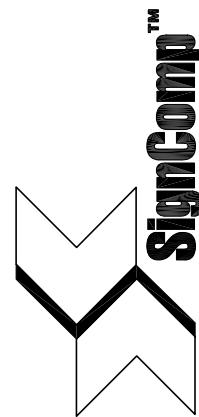

EC-6 for Rigid Faces - Structural

Single Face Filler
Part #2034

Extended Econo Molding
Part #2058

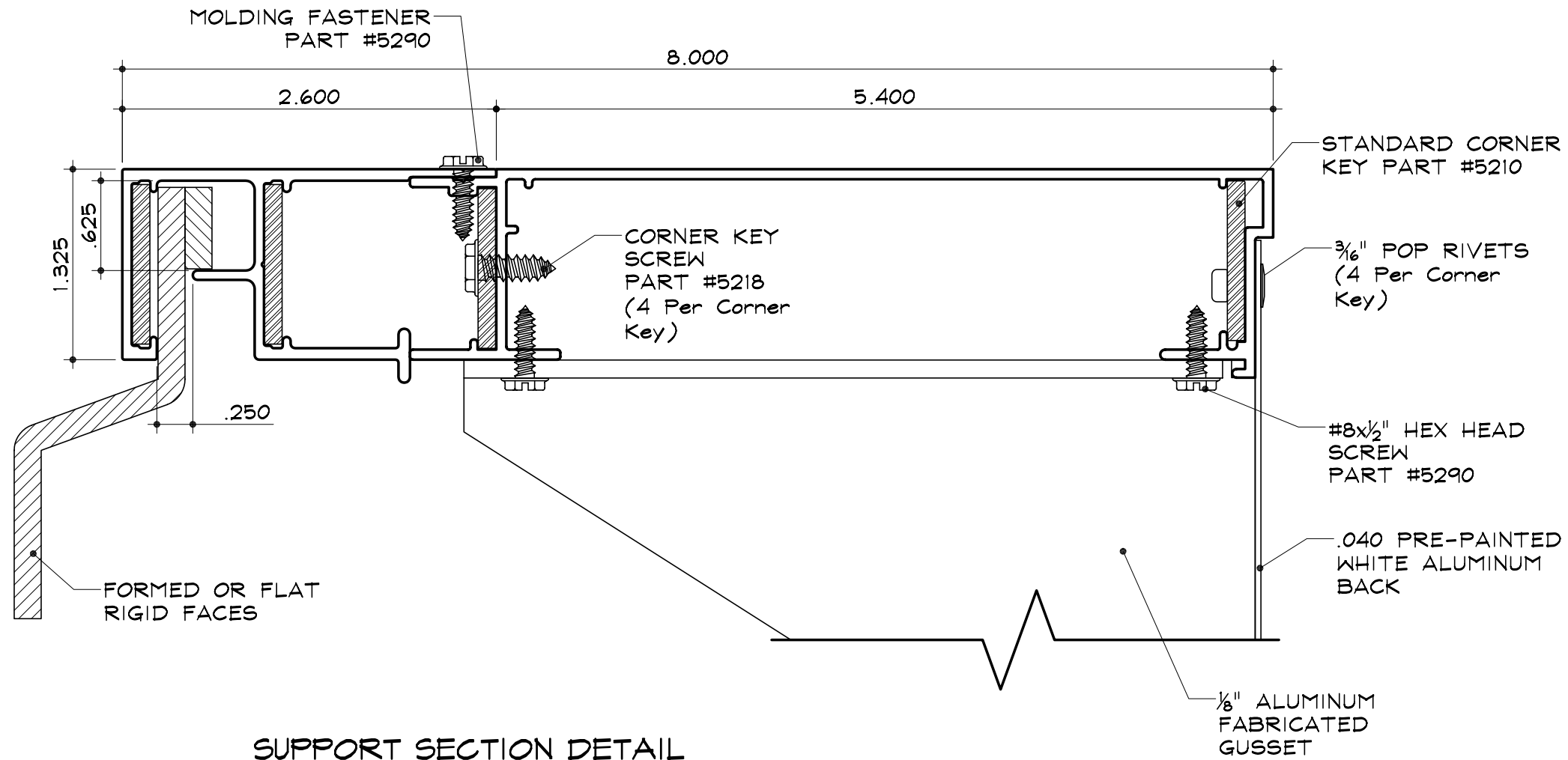

SUPPORT SECTION DETAIL

SCALE : 1" = 1"

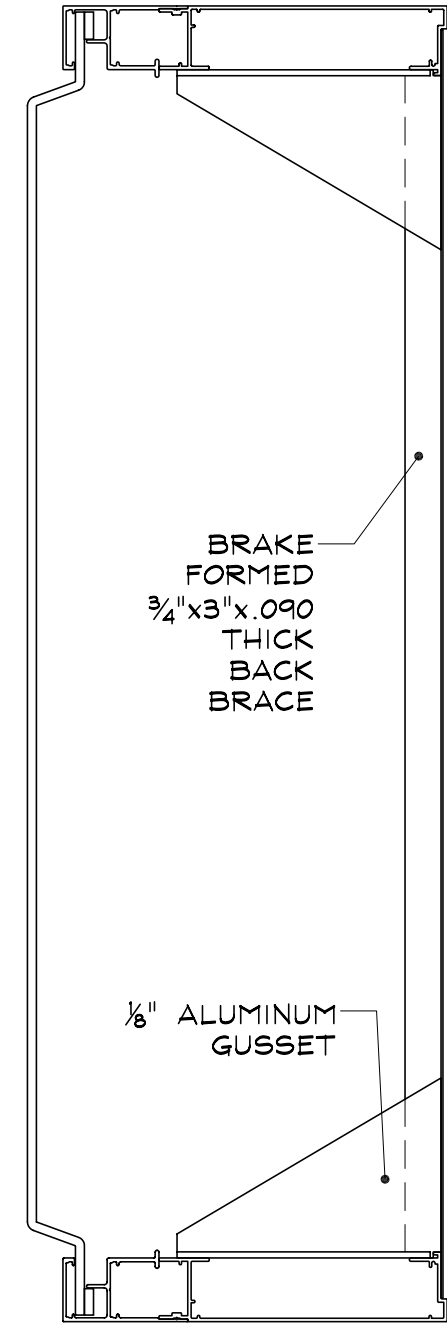

FULL SECTION DETAIL

SCALE : 3" = 1"

NOTES:

- 1. SignComp does not supply the Gussets, Back Braces, Joiner Bracket or Aluminum Back.

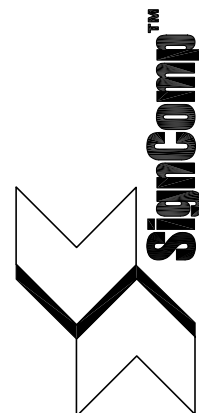

EC-6 for Rigid Faces - Electrical

Single Face Filler
Part #2034

Extended Econo Molding
Part #2058

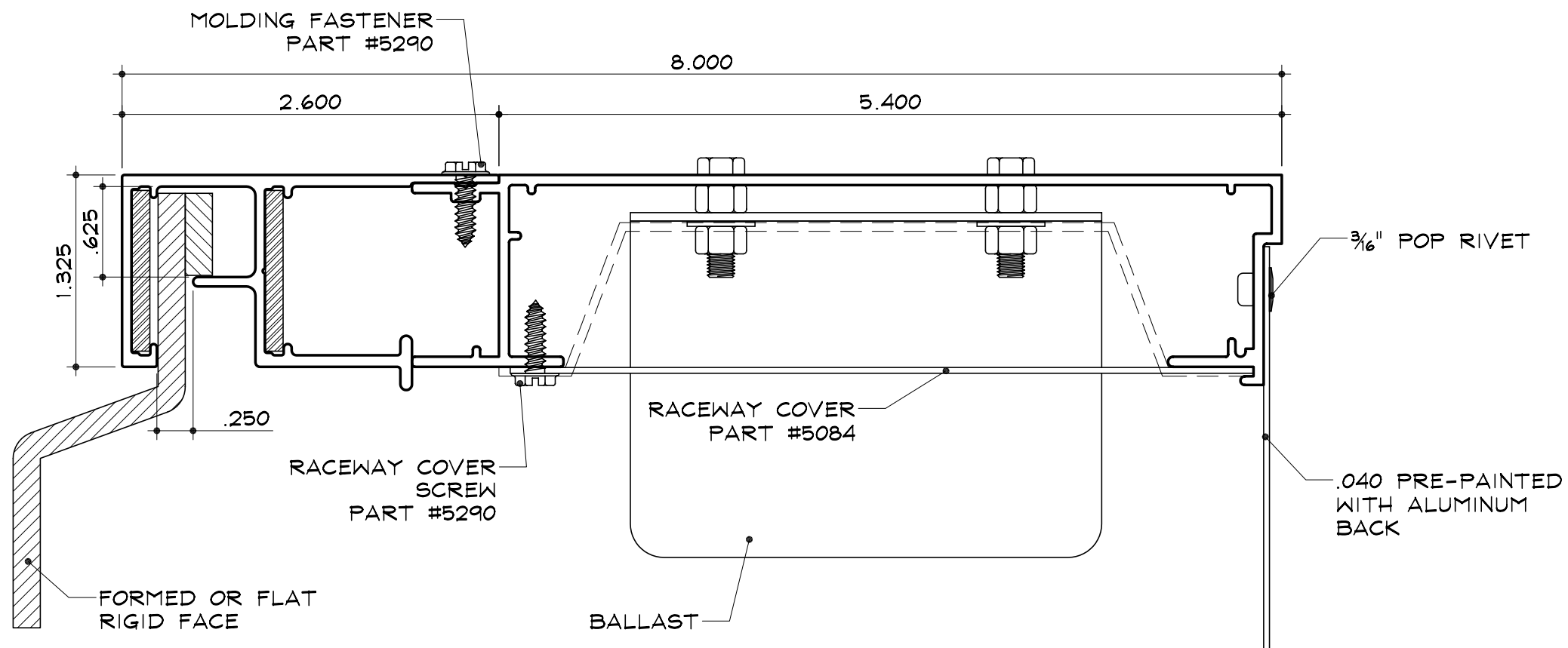

SECTION DETAIL

SCALE : 1" = 1"

NOTES:

1. Add 1" to the size of the cabinet (vertical or horizontal) when the size of the cabinet is the same as the nominal lamp length.
2. SignComp does not supply the Ballast(s), Lamps, Lamp Sockets, Raceway Covers, Raceway Cover Screws, Ballast Pans or Aluminum Back.

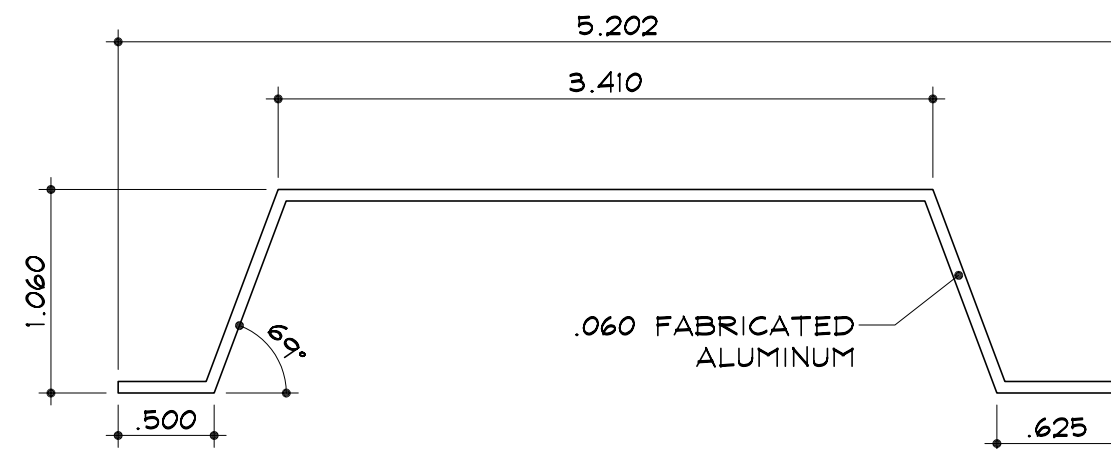

BALLAST PAN DETAIL

SCALE : 1" = 1"